

ACT8600 – Rad Hard Dual Adjustable Positive & Negative Voltage Regulator

COMMON FEATURES

- Radiation 50K Total Dose
- Output voltage adjustable from 1.2V to 37V
- 1.5A output current
- Current limit temperature independent
- Line regulation .01% typ
- Output short circuit protected
- Packaging – Hermetic Metal
 - 6 Leads, .65" x .42" x .200" Power Package
- Industrial, Military and Space Temperature Range
- DESC SMD – TBD

POSITIVE FEATURES

- Load regulation 0.1% typ
- Ripple rejection 80dB typ

NEGATIVE FEATURES

- Load regulation 0.3% typ
- Ripple rejection 77dB typ



General Description

Aeroflex's ACT8600 is a radiation hardened, Dual adjustable 6-terminal device containing a positive (LM117) and a negative (LM137) voltage regulator each capable of supplying in excess of 1.5A over an output voltage range of 1.2V to 37V. Each regulator is exceptionally easy to set-up, requiring only 2 external resistors to set the output voltage. The module design has been optimized for excellent regulation and low thermal transients. There is full electrical isolation between positive and negative regulators and each to the package.

Further, the ACT8600 features internal current limiting, thermal shutdown and safe-area compensation, making them virtually blowout-proof against overloads. The ACT8600 serves a wide variety of applications including local on-card regulation, programmable output voltage regulation or precision current regulation.

The ACT8600 has been specifically designed to meet exposure to radiation environments. It is available in a 6 lead Metal Power Package. It is guaranteed operational from -55°C to +125°C. Available screened to MIL-STD-883, the ACT8600 is ideal for demanding industrial, military and space applications.

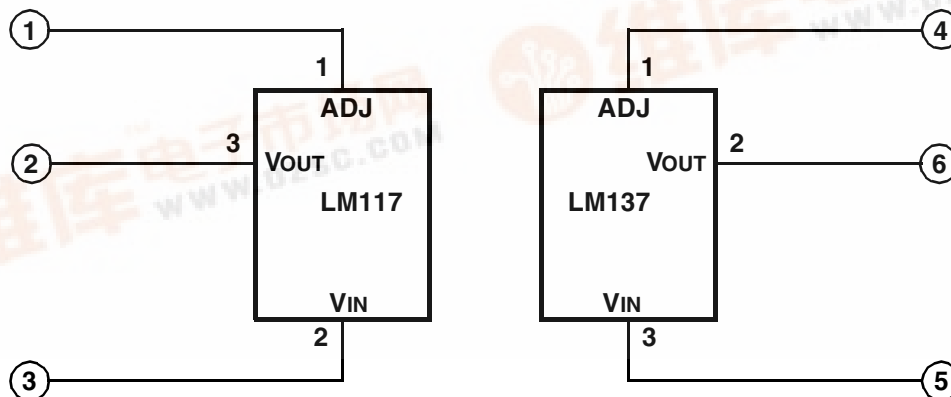

Block Diagram / Schematic



Absolute Maximum Ratings

Parameter	Range	Units
Power Dissipation (Pd)	20	W
Operating (Junction) Temperature Range	-55 to +150	°C
Lead Temperature (soldering, 10 sec)	300	°C
Storage Temperature Range	-65 to +150	°C
Input-Output Voltage Differential	40	V
Thermal Resistance (junction to case Θ_{JC})	5	°C/W
ESD Rating	2	KV

NOTICE: Stresses above those listed under "Absolute Maximums Rating" may cause permanent damage to the device. These are stress rating only; functional operation beyond the "Operation Conditions" is not recommended and extended exposure beyond the "Operation Conditions" may effect device reliability.

Recommended Operating Conditions

Parameter	Range	Units
Output Voltage Range	1.2 to 37	V dc
Positive Voltage Regulator	-1.2 to -37	V dc
Negative Voltage Regulator		
Ambient Operating Temperature Range	-55 to +125	°C
Input Voltage Range	4.25 to 41.25	V dc
Positive Voltage Regulator	-4.25 to -41.25	V dc
Negative Voltage Regulator		

Positive Regulator Electrical Performance Characteristics

(TA = -55°C to +125°C, IL = 8mA, Unless otherwise specified)

Parameter	Sym	Conditions	Min	Max	Units
Reference Voltage	VREF	VDIF = 3.0V, TA = + 25°C	1.2	1.3	V
		VDIF = 3.3V	1.2	1.3	V
		VDIF = 40V	1.2	1.3	V
Line Regulation	RLINE	3.0V ≤ VDIF ≤ 40V, VOUT = VREF, TA = + 25°C	-	±9	mV
		3.3V ≤ VDIF ≤ 40V, VOUT = VREF	-	±23	mV
Load Regulation <u>1/</u>	RLOAD	VDIF = 3.0V, 10mA < IL < 1.5A, TA = + 25°C	-	±15	mV
		VDIF = 3.3V, 10mA < IL < 1.5A	-	±15	mV
		VDIF = 40V, 10mA < IL < 300mA, TA = + 25°C	-	±15	mV
		VDIF = 40V, 10mA < IL < 195mA	-	±15	mV
Thermal Regulation	VRTH	VIN = +14.6V, IL = 300mA, t = 20ms, PD = 20W, TA = + 25°C	-	±16	mV
Ripple Rejection	RN	f = 120Hz, CADJ = 10µF, VOUT = VREF <u>2/</u>	66	-	dB
Adjustment Pin Current	IADJ	VDIF = 3.0V, TA = + 25°C	-	100	µA
		VDIF = 3.3V	-	100	µA
		VDIF = 40V	-	100	µA
Adjustment Pin Current Change	ΔIADJ	VDIF = 3.0V, 10mA < IL < 1.5A, TA = + 25°C	-	±5	µA
		VDIF = 3.3V, 10mA < IL < 1.5A	-	±5	µA
		VDIF = 40V, 10mA < IL < 300mA, TA = + 25°C	-	±5	µA
		VDIF = 40V, 10mA < IL < 195mA	-	±5	µA

Positive Regulator
Electrical Performance Characteristics (con't)

(TA = -55°C to +125°C, IL = 8mA, Unless otherwise specified)

Parameter	Sym	Conditions	Min	Max	Units
Adjustment Pin Current Change con't	ΔI_{ADJ}	3V < V _{DIF} < 40V, TA = + 25°C	-	±5	µA
		3.3V < V _{DIF} < 40V	-	±5	µA
Minimum Load Current	I _{LMIN}	V _{DIF} = 3.0V, V _{OUT} = 1.4 (forced), TA = + 25°C	-	5	mA
		V _{DIF} = 3.3V, V _{OUT} = 1.4 (forced)	-	5	mA
		V _{DIF} = 40V, V _{OUT} = 1.4 (forced)	-	5	mA
Current Limit <u>2/</u>	I _{CL}	V _{DIF} = 15V	1.5	3.5	A
		V _{DIF} = 40V, TA = + 25°C	0.18	1.5	A

Notes:

1/ Regulation is measured at a constant junction temperature, using pulse testing with a low duty cycle. Changes in output voltage due to heating effects are covered under the specification for thermal regulation. With exception of cases U and 2, all output measurements are referenced to the case. Measurements taken at the output lead must be adjusted for lead resistance.

2/ If not tested, shall be guaranteed to the specified limits.

Negative Regulator
Electrical Performance Characteristics

(TA = -55°C to +125°C, IL = 8mA, Unless otherwise specified)

Parameter	Sym	Conditions	Min	Max	Units
Reference Voltage	V _{REF}	V _{DIF} = 3.0V, TA = + 25°C	-1.275	-1.225	V
		V _{DIF} = 3.0V	-1.3	-1.2	V
		V _{DIF} = 40V, TA = + 25°C	-1.275	-1.225	V
		V _{DIF} = 40V	-1.3	-1.2	V
Line Regulation	R _{LINE}	3.0V ≤ V _{DIF} ≤ 40V, V _{OUT} = V _{REF} , TA = + 25°C	-	±9	mV
		3.0V ≤ V _{DIF} ≤ 40V, V _{OUT} = V _{REF}	-	±23	mV
Load Regulation <u>1/</u>	R _{LOAD}	V _{DIF} = 12V, 8mA < I _L < 1.5A, TA = + 25°C	-	±25	mV
		V _{DIF} = 5V, 8mA < I _L < 1.5A	-	±25	mV
		V _{DIF} = 40V, 8mA < I _L < 200mA, TA = + 25°C	-	±25	mV
		V _{DIF} = 40V, 8mA < I _L < 100mA	-	±25	mV
Thermal Regulation	V _{RTH}	V _{IN} = -14.6V, I _L = 1.5A, t = 10ms, P _D = 20W, TA = + 25°C	-	±5	mV
Ripple Rejection	R _N	f = 120Hz, C _{ADJ} = 10µF, V _{OUT} = V _{REF} <u>2/</u>	66	-	dB
Adjustment Pin Current	I _{ADJ}	V _{DIF} = 3.0V	-	100	µA
		V _{DIF} = 40V	-	100	µA
Adjustment Pin Current Change	ΔI_{ADJ} (Line)	3.0V ≤ V _{DIF} ≤ 40V	-	±5	µA
	ΔI_{ADJ} (Load)	V _{DIF} = 5.0V, 8mA < I _L < 1.5A	-	±5	µA
Minimum Load Current	I _{LMIN}	V _{DIF} = 3.0V, V _{OUT} = -1.4 (forced)	-	3	mA
		V _{DIF} = 10V, V _{OUT} = 1.4 (forced)	-	3	mA
		V _{DIF} = 40V, V _{OUT} = 1.4 (forced)	-	5	mA
Current Limit <u>2/</u>	I _{CL}	V _{DIF} = 5V	1.5	3.5	A
		V _{DIF} = 40V, TA = + 25°C	0.24	1.2	A

Notes:

1/ Regulation is measured at a constant junction temperature, using pulse testing with a low duty cycle. Changes in output voltage due to heating effects are covered under the specification for thermal regulation. With exception of cases U and 2, all output measurements are referenced to the case. Measurements taken at the output lead must be adjusted for lead resistance.

2/ If not tested, shall be guaranteed to the specified limits.

Package Outline — Power Package

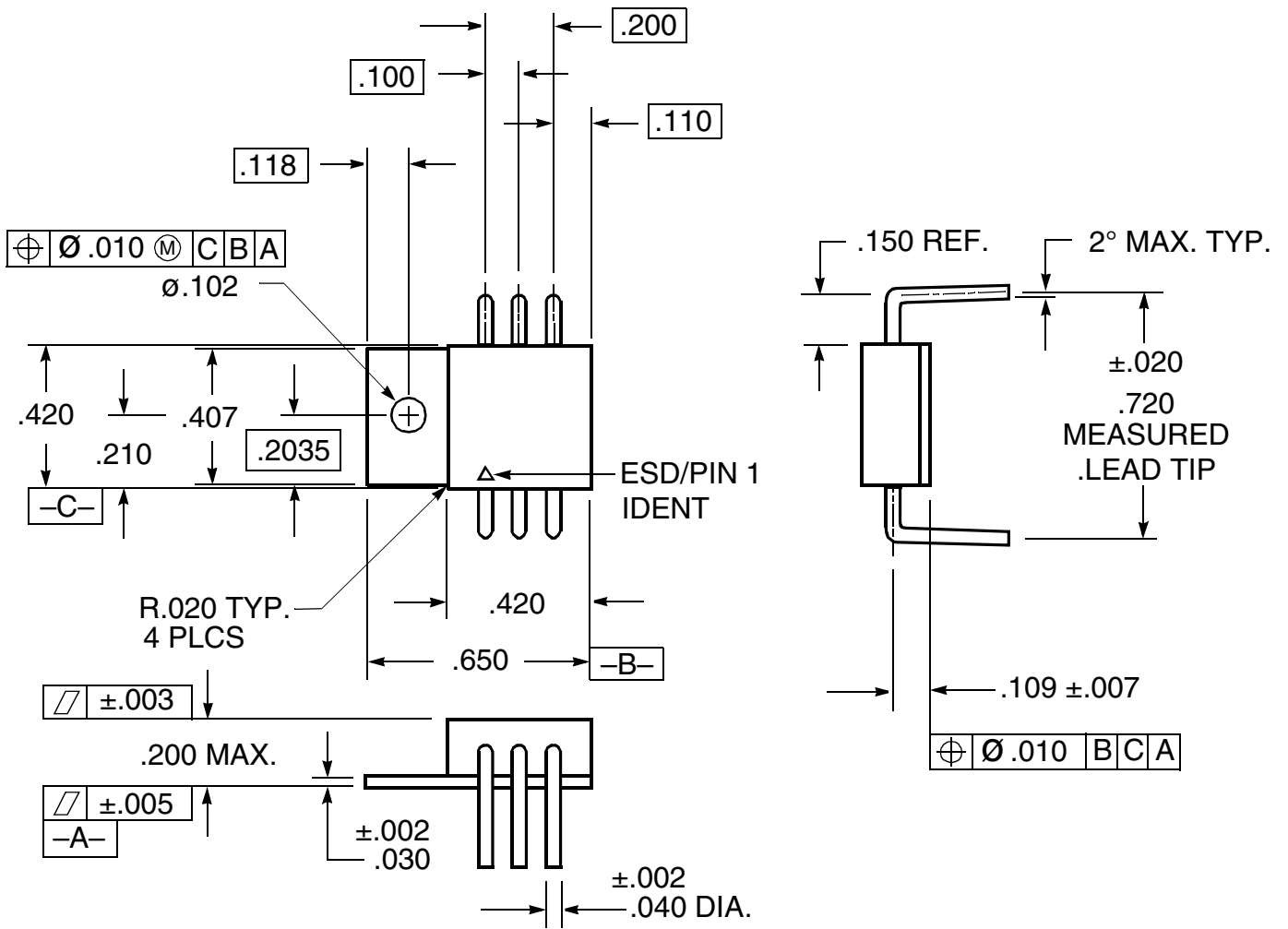

NOTE: 1. Dimension Tolerance: $\pm .005$ inches



Ordering Information

Model Number	Screening	DESC SMD #	Package
ACT8600	Military Temperature, -55°C to +125°C, Screened to the individual test methods of MIL-STD-883	-	6 Lead Power Pkg

Specifications subject to change without notice

Aeroflex Circuit Technology
35 South Service Road
Plainview New York 11803
www.aeroflex.com/act1.htm

Telephone: (516) 694-6700
FAX: (516) 694-6715
Toll Free Inquiries: (800) THE-1553
E-Mail: sales-act@aeroflex.com