



400 MHz to 2700 MHz Pre-driver RF Amplifier

Preliminary Technical Data

ADL5320

FEATURES

- Operation from 400 MHz to 2700 MHz
- Gain of +13.7 dB Gain at 2140 MHz
- OIP3 of +42.0 dBm at 2140 MHz
- P1dB +25.6 dBm at 2140 MHz
- Noise Figure of 4.2 dB at 2140 MHz
- 5V power supply
- 104 mA Power Supply Current
- Internal Active Biasing
- Thermally Efficient SOT-89 Package

GENERAL DESCRIPTION

The ADL5320 is a broadband, linear pre-driver RF amplifier that operates at frequencies from 400 MHz to 2700 MHz. The device can be used in a wide variety of wired and wireless applications, including ISM, WLL, PCS, GSM, CDMA and WCDMA.

The ADL5320 operates with 5V supply voltage with a supply current of 104 mA.

The ADL5320 is fabricated on a GaAs HBT process. The device is packaged in a low-cost SOT-89 that uses an exposed paddle for excellent thermal impedance. It operates from -40°C to +85°C. A fully populated evaluation board is also available.

FUNCTIONAL BLOCK DIAGRAM

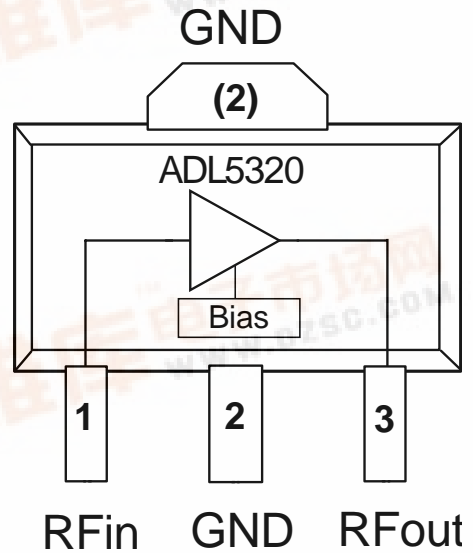

Figure 1.



TABLE OF CONTENTS

Features	1	Pin Configuration and Function Descriptions.....	5
General Description	1	Typical Performance Characteristics	6
Functional Block Diagram	1	Evaluation Board	7
Revision History	2	Outline Dimensions	10
Specifications.....	3	Ordering Guide	10
Absolute Maximum Ratings.....	4		
ESD Caution.....	4		

REVISION HISTORY

5/07—Rev. PrB: Preliminary Version

SPECIFICATIONS

VPOS = 5 V and $T_A = 25^\circ\text{C}$, unless otherwise noted.

Table 1.

Parameter	Conditions	Min	Typ	Max	Unit
OVERALL FUNCTION					
Frequency Range		400		2700	MHz
Input Return Loss (S11)			-10		dB
Output Return Loss (S22)			-10		dB
Reverse Isolation (S12)			-26		dB
FREQUENCY = 880 MHz					
Gain			17.9		dB
vs. Frequency	± 50 MHz		± 0.4		dB
vs. Temperature	$-40^\circ\text{C} \leq T_A \leq +85^\circ\text{C}$		± 0.6		dB
vs. Supply	4.75 V to 5.25 V		TBD		dB
Output 1 dB Compression Point			25.8		dBm
Output Third-Order Intercept	$\Delta f = 1$ MHz, Output Power (P_{OUT}) = 10 dBm per tone		47.8		dBm
Noise Figure	VPOS = 5 V		3.8		dB
FREQUENCY = 2140 MHz					
Gain			13.7		dB
vs. Frequency	± 30 MHz		± 0.2		dB
vs. Temperature	$-40^\circ\text{C} \leq T_A \leq +85^\circ\text{C}$		± 0.9		dB
vs. Supply	4.75 V to 5.25 V		TBD		dB
Output 1 dB Compression Point			25.6		dBm
Output Third-Order Intercept	$\Delta f = 1$ MHz, $P_{\text{OUT}} = 10$ dBm per tone		42.0		dBm
Noise Figure	VPOS = 5 V		4.2		dB
FREQUENCY = 2350 MHz					
Gain			12.6		dB
vs. Frequency	± 50 MHz		± 0.25		dB
vs. Temperature	$-40^\circ\text{C} \leq T_A \leq +85^\circ\text{C}$		± 0.88		dB
vs. Supply	4.75 V to 5.25 V		TBD		dB
Output 1 dB Compression Point			26.1		dBm
Output Third-Order Intercept	$\Delta f = 1$ MHz, $P_{\text{OUT}} = 10$ dBm per tone		42.8		dBm
Noise Figure	VPOS = 5 V		4.6		dB
POWER INTERFACE					
Supply Voltage	Pins RFOUT, Vcc	4.75	5	5.25	V
Supply Current			104		mA
vs. Temp	$-40^\circ\text{C} \leq T_A \leq +85^\circ\text{C}$		109		mA
Power Dissipation	VPOS = 5 V		520		mW

ABSOLUTE MAXIMUM RATINGS

Table Summary

Table 2.

Parameter	Rating
Supply Voltage, VPOS	6 V
Input Power (re: 50 Ω)	+20 dBm
Internal Power Dissipation (Paddle Soldered)	660 mW
θ_{JC} (Junction to Paddle)	TBD $^{\circ}\text{C}/\text{W}$
Maximum Junction Temperature	TBD $^{\circ}\text{C}$
Operating Temperature Range	-40°C to $+85^{\circ}\text{C}$
Storage Temperature Range	-65°C to $+150^{\circ}\text{C}$

Stresses above those listed under Absolute Maximum Ratings may cause permanent damage to the device. This is a stress rating only; functional operation of the device at these or any other conditions above those indicated in the operational section of this specification is not implied. Exposure to absolute maximum rating conditions for extended periods may affect device reliability.

ESD CAUTION



ESD (electrostatic discharge) sensitive device. Charged devices and circuit boards can discharge without detection. Although this product features patented or proprietary protection circuitry, damage may occur on devices subjected to high energy ESD. Therefore, proper ESD precautions should be taken to avoid performance degradation or loss of functionality.

PIN CONFIGURATION AND FUNCTION DESCRIPTIONS

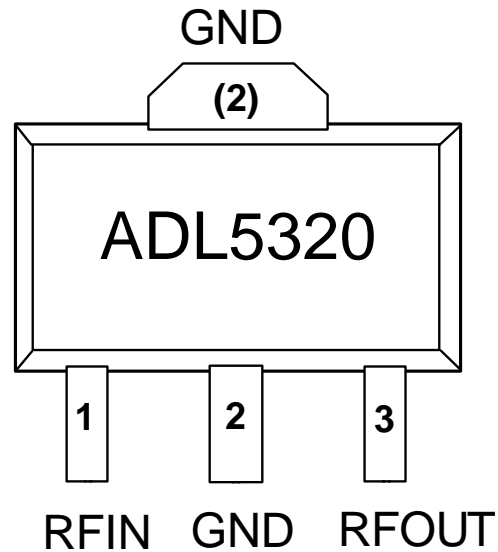

Figure 2.

Table 3. Pin Function Descriptions

Pin No.	Mnemonic	Description
1	RFIN	RF Input. Requires a dc blocking capacitor
2	GND	Ground: Connect to a low impedance ground plane
3	RFOUT	RF Output and Supply Voltage: DC bias is provided to this pin through an inductor that is tied to the external power supply . RF path requires a DC blocking capacitor.
Exposed Paddle		Exposed Paddle: Internally connected to GND. Solder to a low impedance ground plane.

TYPICAL PERFORMANCE CHARACTERISTICS

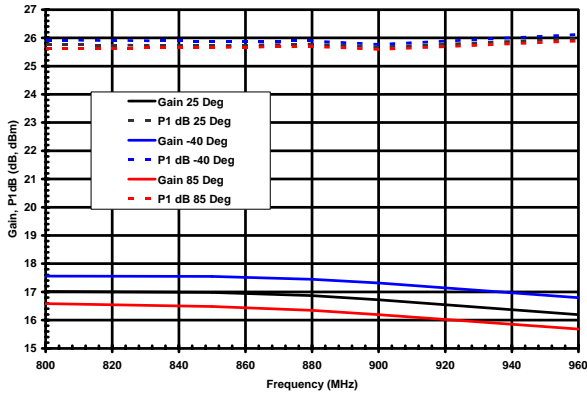

Figure 3. Gain and P1dB vs. Frequency and Temperature 800MHz – 960 MHz
Pout = 10 dBm

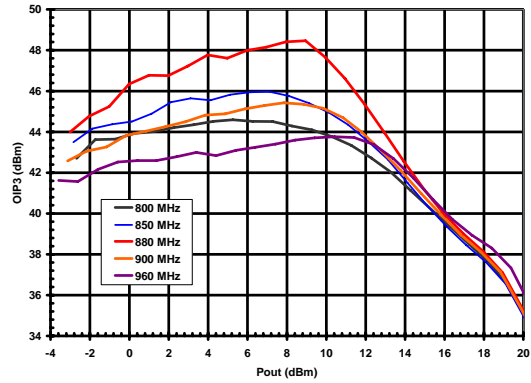

Figure 6. OIP3 vs. Pout and Frequency 800 MHz – 960 MHz

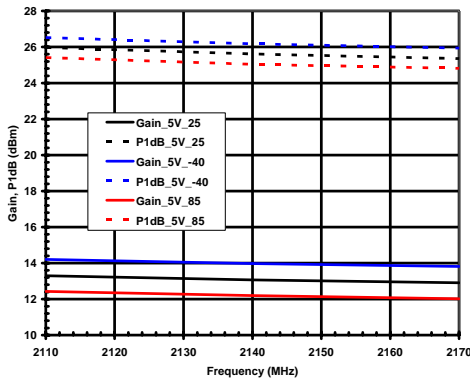

Figure 4. Gain and P1dB vs. Frequency and Temperature 2110MHz – 2170 MHz
Pout = 10 dBm

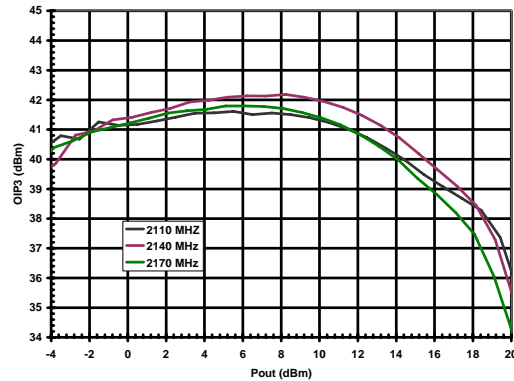

Figure 7. OIP3 vs. Pout and Frequency 2100 MHz – 2170 MHz

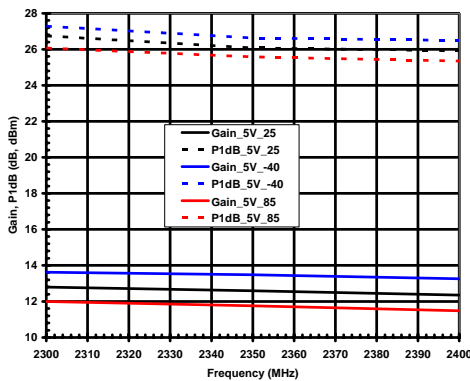

Figure 5. Gain and P1dB vs. Frequency and Temperature 2300MHz – 2400 MHz
Pout = 10 dbm

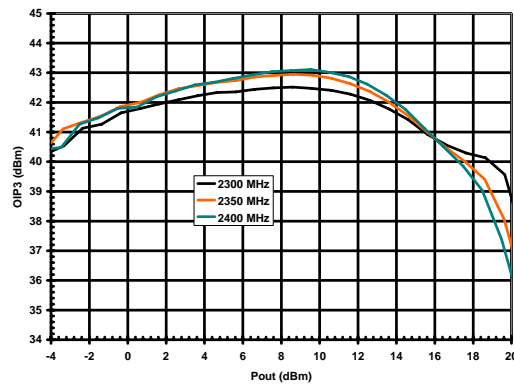

Figure 8. OIP3 vs. Pout and Frequency 2300 MHz – 2400 MHz

EVALUATION BOARD

The basic connections for operating the ADL5320 are shown in Figure 9. The inputs and outputs should be ac coupled with appropriately sized capacitors. DC bias is provided to the amplifier via an inductor connected to the RF output pin. A bias voltage of 5 V is recommended.

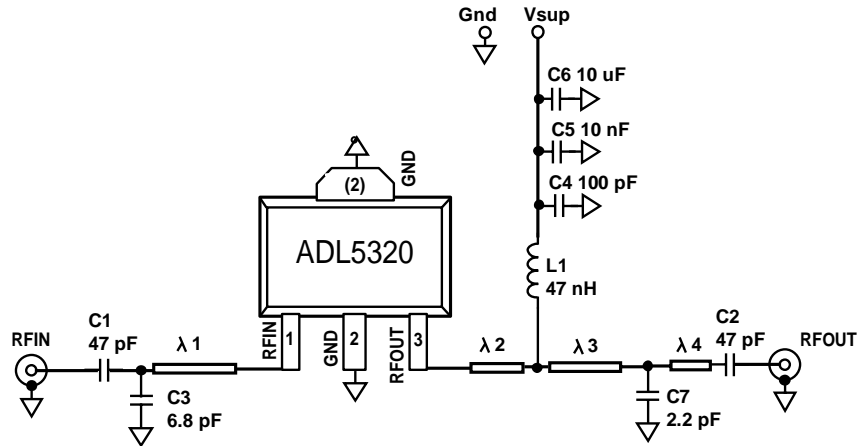

Figure 9. Basic Connections default condition is for 800 MHz to 960 MHz

Table 4. Matching Component Spacing 800 MHz – 960 MHz

$\lambda 1^1$	$\lambda 2$	$\lambda 3$	$\lambda 4$
200 mils	75 mils	100 mils	350 mils

¹ 50 ohm traces 25 mils wide, substrate used is FR4

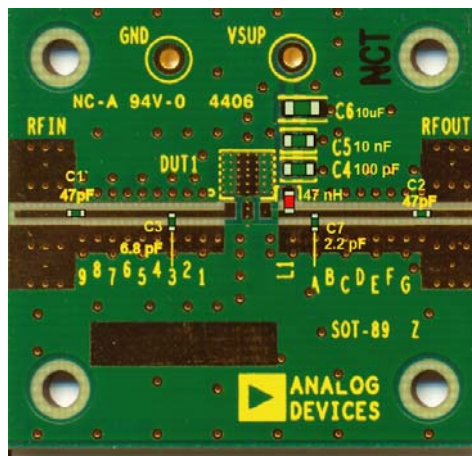

Figure 10. Evaluation Board Layout showing component placement 800 MHz to 960 MHz operation

Table 5. Evaluation Board Configuration Options 800 MHz - 960 MHz

Component	Function	Default Value
C1, C2	AC - coupling capacitors	0402 47 pF
C4, C5, C6	Power supply bypassing capacitors	C4 0603 100 pF C5 0603 10 nF C6 1206 10μF
L1	DC bias inductor	0603 47 nH
C3, C7	Tuning capacitors	C3 0402 6.8 pF C7 0402 2.2 pF
Vsup, Gnd	Power supply connections	Vsup red testloop Gnd Black testloop

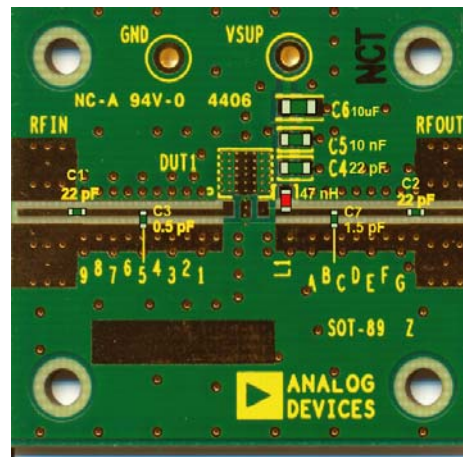

Figure 11. Evaluation Board Layout showing component placement 2110 MHz to 2170 MHz operation

Table 5. Matching Component Spacing 2110 MHz – 2170 MHz

$\lambda 1^1$	$\lambda 2$	$\lambda 3$	$\lambda 4$
300 mils	75 mils	175 mils	275mils

¹ 50 ohm traces 25 mils wide, substrate used is FR4

Table 6. Evaluation Board Configuration Options 2110 MHz – 2170 MHz

Component	Function	Default Value
C1, C2	AC - coupling capacitors	0402 22 pF
C4, C5, C6	Power supply bypassing capacitors	C4 0603 22 pF C5 0603 10 nF C6 1206 10μF
L1	DC bias inductor	0603 47 nH
C3, C7	Tuning capacitors	C3 0402 0.5 pF C7 0402 1.5 pF
Vsup, Gnd	Power supply connections	Vsup red testloop Gnd Black testloop

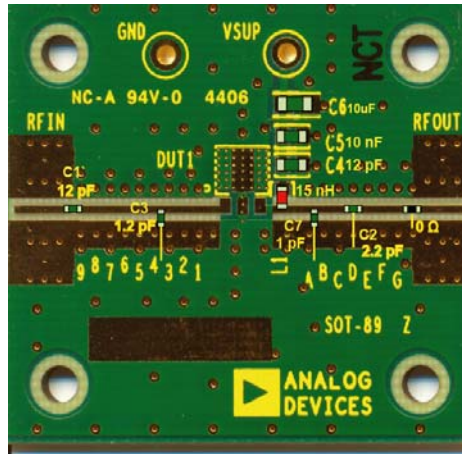

Figure 12. Evaluation Board Layout showing component placement 2300 MHz to 2400 MHz operation

Table 7. Matching Component Spacing 2300 MHz – 2400 MHz

$\lambda 1^1$	$\lambda 2$	$\lambda 3$	$\lambda 4$
225 mils	75 mils	125 mils	125mils

¹ 50 ohm traces 25 mils wide, substrate used is FR4

Table 8. Evaluation Board Configuration Options 2300 MHz to 2400 MHz

Component	Function	Default Value
C1, C2	AC - coupling capacitors	C1 0402 12 pF C2 0402 2.2 pF
C4, C5, C6	Power supply bypassing capacitors	C4 0603 12 pF C5 0603 10 nF C6 1206 10µF
L1	DC bias inductor	0603 15 nH
C3, C7	Tuning capacitors	C3 0402 1.2 pF C7 0402 1.0 pF
Vsup, Gnd	Power supply connections	Vsup red testloop Gnd Black testloop

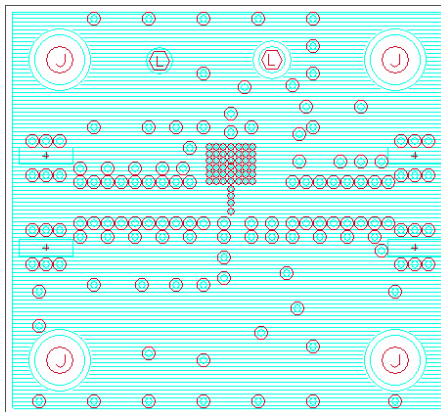
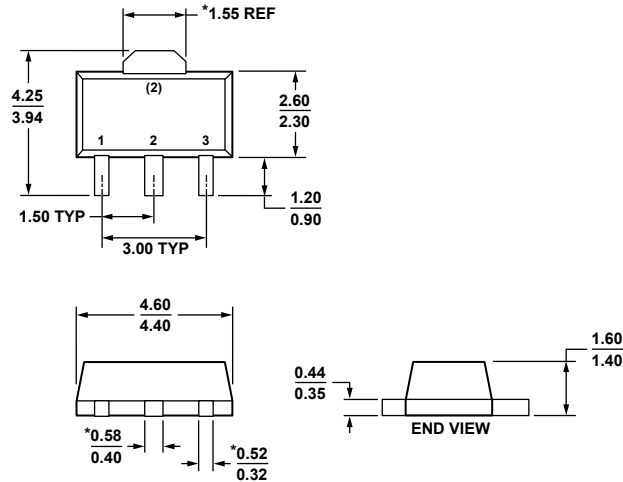

Figure 13. Evaluation Board Layout (BOTTOM)

OUTLINE DIMENSIONS



*COMPLIANT TO JEDEC STANDARDS TO-243 WITH EXCEPTION TO DIMENSIONS INDICATED BY AN ASTERISK.

Figure 14. 3-Lead Small Outline Transistor Package [SOT-89] (RK-3)
Dimensions shown in millimeters

0-00407-A

ORDERING GUIDE

Model	Temperature Range	Package Description	Package Option	Branding	Ordering Quantity
ADL5320ARKZ-R7 ¹	-40°C to +85°C	3 Lead SOT89 Tape and Reel	RK-3	TBD	TBD
ADL5320ARKZ-WP ¹	-40°C to +85°C	3 Lead SOT89 Waffle Pack	RK-3	TBD	TBD
ADL5230-EVALZ		Evaluation Board			

¹ Z = RoHS Compliant Part.