



ADS7833

10-Channel, 12-Bit DATA ACQUISITION SYSTEM

FEATURES

- 3 SIMULTANEOUS SAMPLED CHANNELS
- 3 SYNCHRONIZED 12-BIT ADCs
- 6.6 μ s THROUGHPUT RATE
- FULLY DIFFERENTIAL MUX INPUTS
- DIGITALLY SELECTABLE INPUT RANGES
- ± 5 V POWER SUPPLIES
- SERIAL DIGITAL INPUT/OUTPUTS
- 2 SIMULTANEOUS SAMPLED AUXILIARY CHANNELS
- DIRECT INTERFACE TO MOTOROLA'S DSP56004/7

DESCRIPTION

The ADS7833 consists of three 12-bit analog-to-digital converters preceded by three simultaneously operating sample-hold amplifiers, and multiplexers for 10 differential inputs. The ADCs have simultaneous serial outputs for high speed data transfer and data processing.

The ADS7833 also offers a programmable gain amplifier with programmable gains of 1.0V/V, 1.25V/V, 2.5V/V, and 5.0V/V. Channel selection and gain selection are selectable through the serial input control word. The high throughput rate is maintained by simultaneously clocking in the 13-bit input control word for the next conversion while the present conversions are clocked out.

The part also contains an 8-bit digital-to-analog converter whose digital input is supplied as part of the input control word.

APPLICATIONS

- AC MOTOR SPEED CONTROLS
- THREE PHASE POWER CONTROL
- UNINTERRUPTABLE POWER SUPPLIES
- VIBRATION ANALYSIS
- PC DATA ACQUISITION
- MEDICAL INSTRUMENTATION

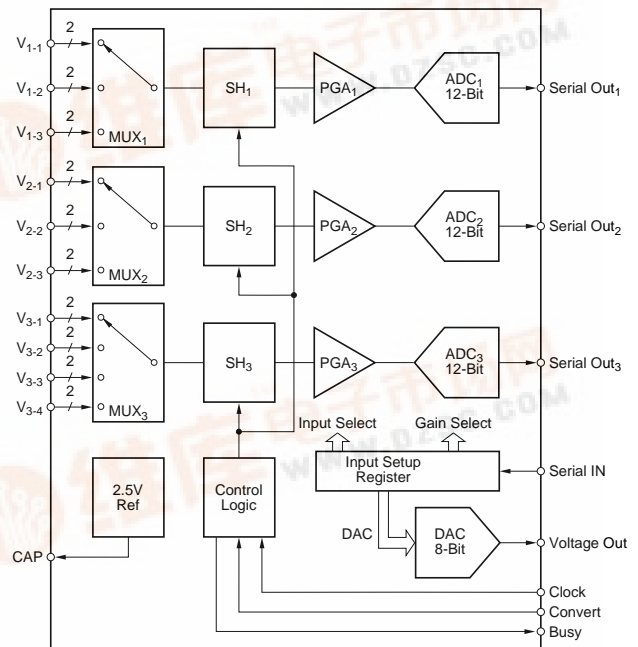

SPECIFICATIONS

At $V_{ANA+} = +5V$, $V_{ANA-} = -5V$, $V_{DIG+} = +5V$, $V_{DIG-} = -5V$, and $T_A = -40^{\circ}C$ to $+85^{\circ}C$, using internal reference, $f_{CLOCK} = 2.1MHz$.

ANALOG-TO-DIGITAL CONVERTER CHANNELS

PARAMETER	CONDITIONS	ADS7833N			UNITS
		MIN	TYP	MAX	
RESOLUTION		12			Bit
ANALOG INPUT Full Scale Voltage, Differential Common-Mode Voltage Impedance Capacitance	$G = 1.0V/V$ $G = 1.25V/V$ $G = 2.5V/V$ $G = 5.0V/V$		± 2.5 ± 2.0 ± 1.0 ± 0.5 See Table VII		V V V V V Ω pF
THROUGHPUT SPEED Conversion Time Complete Cycle Throughput Rate	CLK = 2.1MHz Acquire and Convert			6.1 6.6	μs μs kHz
SAMPLING DYNAMICS S/H Droop Rate S/H Acquisition Time S/H Aperture Delay S/H Aperture Jitter Sampling Skew, Channel-to-Channel			0.1 0.5 50 50 3		$\mu V/\mu s$ μs ns ps ns
DC ACCURACY Integral Linearity - ADC Differential Linearity - ADC No Missing Codes Integral Linearity - Asynchronous, Synchronous Differential Linearity - Asynchronous, Synchronous Full Scale Error Full Scale Error Other Gains Full Scale Error Drift Zero Error - ADC Zero Error - Asynchronous, Synchronous Zero Error Drift	$G = 1.0V/V$ $G = 1.0V/V$ $G = 2.5V/V$ $G = 1.0V/V$ $G = 1.0V/V$ $G = 1.0V/V$	12	± 0.5 ± 0.5 0.5 0.5 ± 10 ± 10 ± 0.5 ± 0.5 ± 0.5	± 2 ± 3 ± 3 2 4 ± 100 ± 100 ± 15 ± 20	LSB LSB Bits LSB LSB % of FSR % of FSR ppm/ $^{\circ}C$ ppm/ $^{\circ}C$ LSB LSB ppm/ $^{\circ}C$
AC ACCURACY Total Harmonic Distortion $f_{IN} = 1kHz$ $f_{IN} = 1MHz$ CMR	$V_{CM} = 1V$, $f_{CM} = 1MHz$		92 72 40		dB dB dB
REFERENCE Internal Reference Voltage Internal Reference Accuracy Internal Reference Drift Internal Reference Source Current External Reference Voltage Range for Specified Linearity External Reference Current Drain			2.5 ± 0.25 ± 10 10 2.5 10	2.75	V % ppm/ $^{\circ}C$ μA V μA
DIGITAL INPUTS Logic Levels V_{IL} V_{IH} I_{IL} I_{IH} Input Capacitance	At All Digital Input Pins	0 +3.5		1.5 +5 ± 10 ± 10 15	V V μA μA pF
DIGITAL OUTPUTS Data Format Data Coding V_{OL} V_{OH} Leakage Current Output Capacitance	$I_{SINK} = 1.6mA$ $I_{SOURCE} = 500\mu A$ At All Digital Output Pins	0 4.2	12-Bit Serial BTC	0.4 5 ± 5 15	V V μA pF

The information provided herein is believed to be reliable; however, BURR-BROWN assumes no responsibility for inaccuracies or omissions. BURR-BROWN assumes no responsibility for the use of this information, and all use of such information shall be entirely at the user's own risk. Prices and specifications are subject to change without notice. No patent rights or licenses to any of the circuits described herein are implied or granted to any third party. BURR-BROWN does not authorize or warrant any BURR-BROWN product for use in life support devices and/or systems.

SPECIFICATIONS (CONT)

At $V_{ANA+} = +5V$, $V_{ANA-} = -5V$, $V_{DIG+} = +5V$, $V_{DIG-} = -5V$, and $T_A = -40^{\circ}C$ to $+85^{\circ}C$, using internal reference, $f_{CLOCK} = 2.1MHz$.

ANALOG-TO-DIGITAL CONVERTER CHANNELS

PARAMETER	CONDITIONS	ADS7833N			UNITS
		MIN	TYP	MAX	
POWER SUPPLIES	Specified Performance				
V_{ANA+}		+4.75	+5.0	+5.25	V
V_{ANA-}		-4.75	-5.0	-5.25	V
V_{DIG+}		+4.75	+5.0	+5.25	V
V_{DIG-}		-4.75	-5.0	-5.25	V
I_{ANA+}		15	25		mA
I_{ANA-}		8	10		mA
I_{DIG+}		3	5		mA
I_{DIG-}		1	2		mA
Power Dissipation		125			mW
TEMPERATURE RANGE					
Specified Performance		-40		+85	$^{\circ}C$
Derated Performance		-55		+125	$^{\circ}C$
Storage		-65		+150	$^{\circ}C$

DIGITAL-TO-ANALOG CONVERTER

PARAMETER	CONDITIONS	ADS7833N			UNITS
		MIN	TYP	MAX	
RESOLUTION	To 0.5LSB	8-Bits			
Output Range		0		+2.5	V
Output Settling Time				1	μs
Linearity Error				± 1	LSB
Differential Linearity				± 1	LSB
Output Current		200			μA
Offset Error			± 1	10	mV
Full Scale Error				2	%

ABSOLUTE MAXIMUM RATINGS

Analog Input Voltage	$\pm 25V$
Ground Voltage Difference: AGND and DGND	$\pm 0.3V$
Power Supply Voltages:	
V_{ANA+}	+7V
V_{ANA-}	-7V
V_{DIG+}	+7V
V_{DIG-}	-7V
Digital Inputs	-0.3V to $V_{DIG} + 0.3V$
Maximum Junction Temperature	$+165^{\circ}C$
Internal Power Dissipation	825mW
Lead Temperature (soldering, 10s)	$+300^{\circ}C$

PIN CONFIGURATION

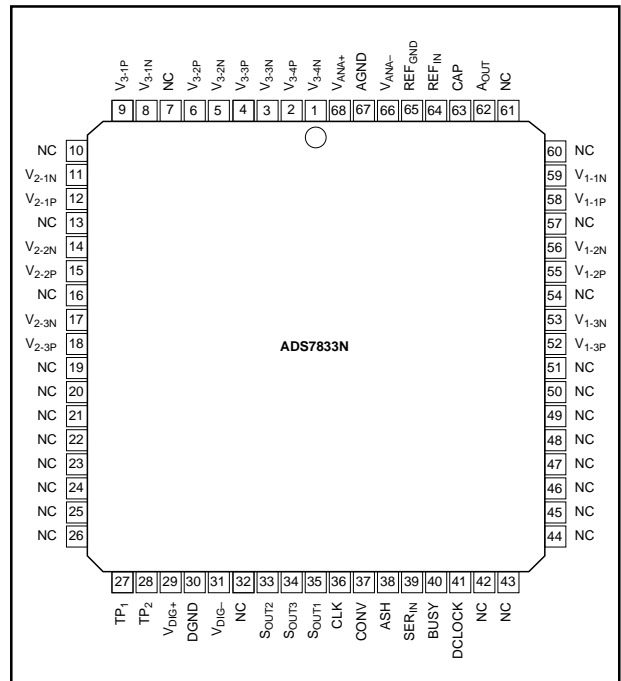

CONVERSION AND DATA TIMING

SYMBOL	DESCRIPTION	MIN	TYP	MAX	UNITS
t_{CONV}	A/D Conversion Time	6.6	4.0		μs
CLK	A/D Conversion Clock	2.1	2.8		MHz
t_1	Setup Time for Conversion Before Rising Edge of Clock	50			ns
t_2	Hold Time for Conversion After Rising Edge of Clock	50			ns
t_3	Setup Time for Serial Out			25	ns
t_4	Setup Time for Serial Input	30			ns
t_5	Hold Time for Serial Input	30			ns

PACKAGE INFORMATION

PRODUCT	PACKAGE	PACKAGE DRAWING NUMBER ⁽¹⁾
ADS7833N	68-Lead PLCC	312

NOTE: (1) For detailed drawing and dimension table, please see end of data sheet, or Appendix C of Burr-Brown IC Data Book.

PIN DEFINITIONS

PIN NO	NAME	TYPE ⁽¹⁾	DESCRIPTION	PIN NO	NAME	TYPE ⁽¹⁾	DESCRIPTION
1	V _{3-4N}	AI	Voltage Input, Channel 3, Mux I/P 4, Negative Side	35	S _{OUT1}	DO	Serial Digital Output, Channel 1
2	V _{3-4P}	AI	Voltage Input, Channel 3, Mux IP 4, Positive Side	36	CLK	DI	Clock for A/D Converters
3	V _{3-3N}	AI	Voltage Input, Channel 3, Mux I/P 3, Negative Side	37	CONV	DI	Start A/D Converters. When CONV goes to "0" (low) the next rising edge of CLK starts the conversion.
4	V _{3-3P}	AI	Voltage Input, Channel 3, Mux I/P 3, Positive Side	38	ASH	DI	Digital Control for Asynchronous Sample Hold. If signal is "1" (high), signals are sampled.
5	V _{3-2N}	AI	Voltage Input, Channel 3, Mux I/P 2, Negative Side	39	SER _{IN}	DI	Serial Digital Input for Input Control Word
6	V _{3-2P}	AI	Voltage Input, Channel 3, Mux I/P 2, Positive Side	40	BUSY	DO	A/D Converters Busy. Busy if signal is "0" (low).
7	NC	—	No Connection	41	DCLOCK	DO	A Delayed and Truncated Version of the CLK Signals. It is Delayed 50ns from the CLK Signal and Stays Low after 13 DCLOCK Cycles.
8	V _{3-1N}	AI	Voltage Input, Channel 3, Mux I/P 1, Negative Side	42	NC	—	No Connection
9	V _{3-1P}	AI	Voltage Input, Channel 3, Mux I/P 1, Positive Side	43	NC	—	No Connection
10	NC	—	No Connection	44	NC	—	No Connection
11	V _{2-1N}	AI	Voltage Input, Channel 2, Mux I/P 1, Negative Side	45	NC	—	No Connection
12	V _{2-1P}	AI	Voltage Input, Channel 2, Mux I/P 1, Positive Side	46	NC	—	No Connection
13	NC	—	No Connection	47	NC	—	No Connection
14	V _{2-2N}	AI	Voltage Input, Channel 2, Mux I/P 2, Negative Side	48	NC	—	No Connection
15	V _{2-2P}	AI	Voltage Input, Channel 2, Mux I/P 2, Positive Side	49	NC	—	No Connection
16	NC	—	No Connection	50	NC	—	No Connection
17	V _{2-3N}	AI	Voltage Input, Channel 2, Mux I/P 3, Negative Side.	51	NC	—	No Connection
18	V _{2-3P}	AI	Voltage Input, Channel 2, Mux I/P 3, Positive Side	52	V _{1-3P}	AI	Voltage Input, Channel 1, Mux I/P 3, Positive Side
19	NC	—	No Connection	53	V _{1-3N}	AI	Voltage Input, Channel 1, Mux I/P 3, Negative Side
20	NC	—	No Connection	54	NC	—	No Connection
21	NC	—	No Connection	55	V _{1-2P}	AI	Voltage Input, Channel 1, Mux I/P 2, Positive Side
22	NC	—	No Connection	56	V _{1-2N}	AI	Voltage Input, Channel 1, Mux I/P 2, Negative Side
23	NC	—	No Connection	57	NC	—	No Connection
24	NC	—	No Connection	58	V _{1-1P}	AI	Voltage Input, Channel 1, Mux I/P 1, Positive Side
25	NC	—	No Connection	59	V _{1-1N}	AI	Voltage Input, Channel 1, Mux I/P 1, Negative Side
26	NC	—	No Connection	60	NC	—	No Connection
27	TP1	—	Test Point 1, Make No Connection	61	NC	—	No Connection
28	TP2	—	Test Point 2, Make No Connection	62	A _{OUT}	AO	Output of DAC
29	V _{DIG+}	P	Digital Supply Voltage, +5V	63	CAP	AO	Decoupling Point for Internal Reference
30	DGND	P	Digital Supply Voltage, Ground	64	REF _{IN}	AI	Input Pin for External Reference
31	V _{DIG-}	P	Digital Supply Voltage, -5V	65	REF _{GND}	P	Ground Pin for External Reference
32	NC	—	No Connection	66	V _{ANA-}	P	Analog Supply Voltage, -5V
33	S _{OUT2}	DO	Serial Digital Output, Channel 2	67	AGND	P	Analog Supply Voltage, Ground
34	S _{OUT3}	DO	Serial Digital Output, Channel 3	68	V _{ANA+}	P	Analog Supply Voltage, +5V

NOTE: (1) AI is Analog Input, AO is Analog Output, DI is Digital Input, DO is Digital Output, P is Power Supply Connection.

TYPICAL PERFORMANCE CURVES

At $V_{ANA+} = +5V$, $V_{ANA-} = -5V$, $V_{DIG+} = +5V$, $V_{DIG-} = -5V$ and $T_A = 25^\circ C$, using internal reference, $f_{CLOCK} = 2.1MHz$.

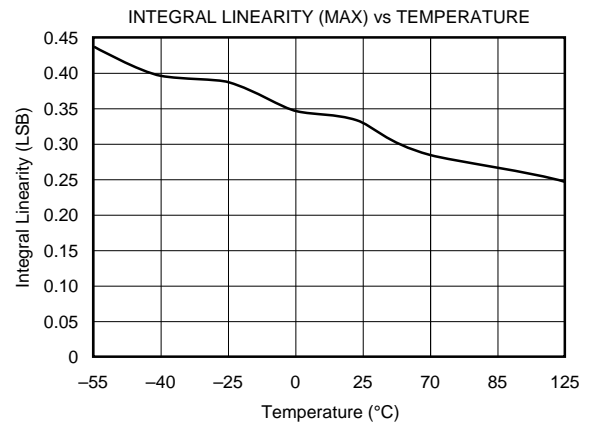
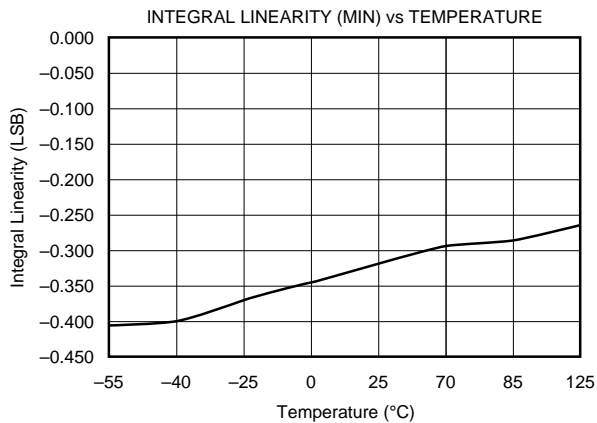
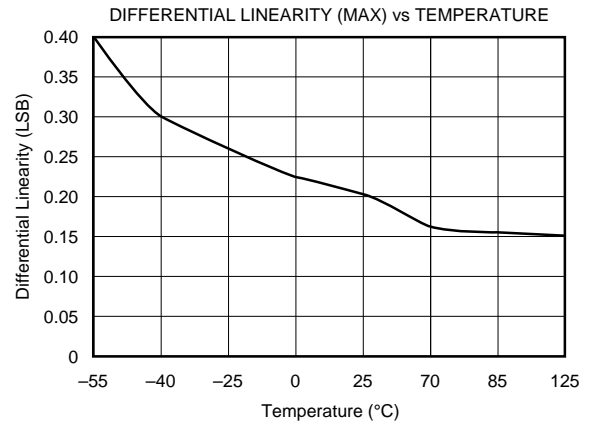
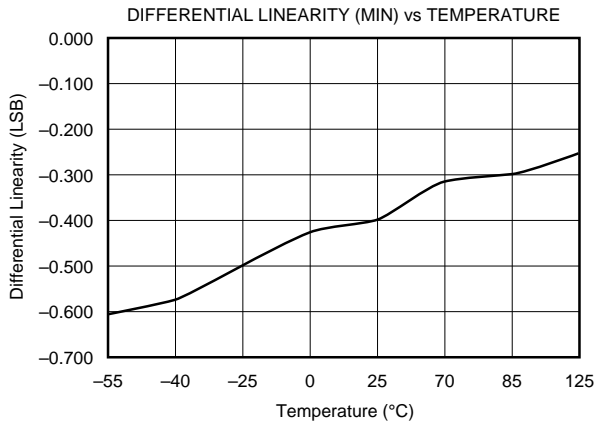
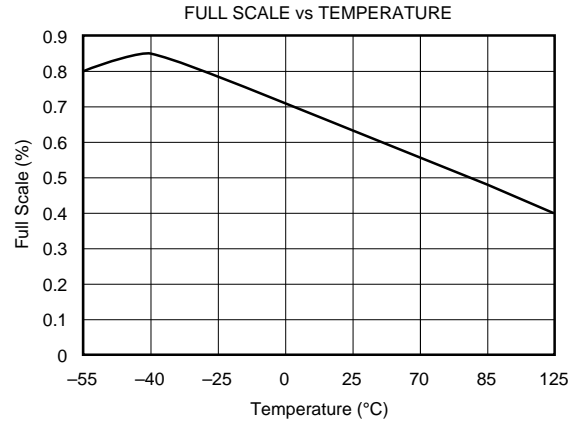
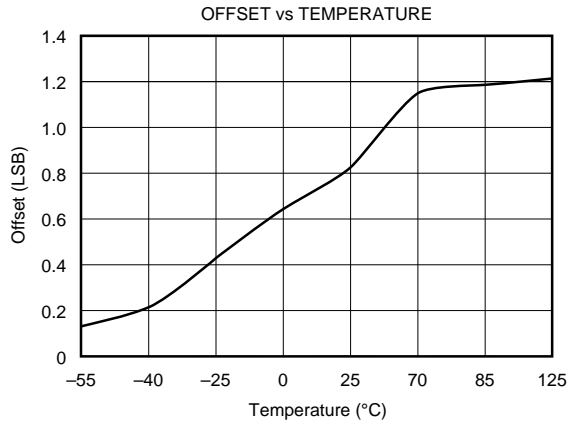

TYPICAL PERFORMANCE CURVES (CONT)

At $V_{ANA+} = +5V$, $V_{ANA-} = -5V$, $V_{DIG+} = +5V$, $V_{DIG-} = -5V$ and $T_A = 25^\circ C$, using internal reference, $f_{CLOCK} = 2.1MHz$.

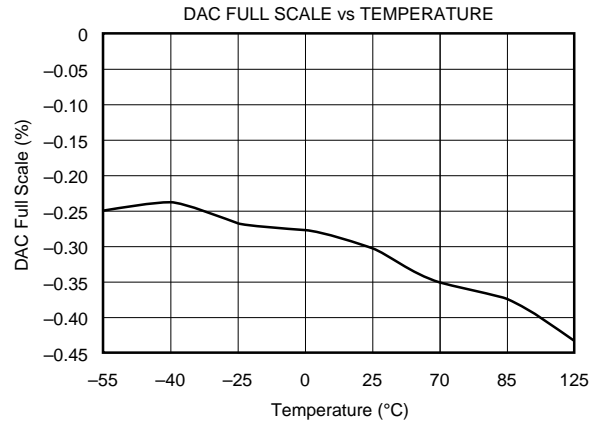
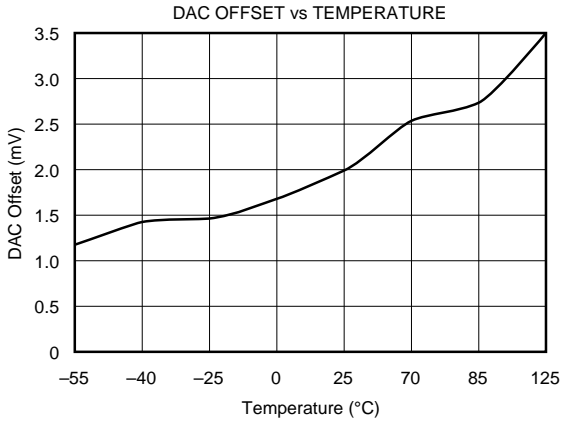

BASIC CIRCUIT CONFIGURATION

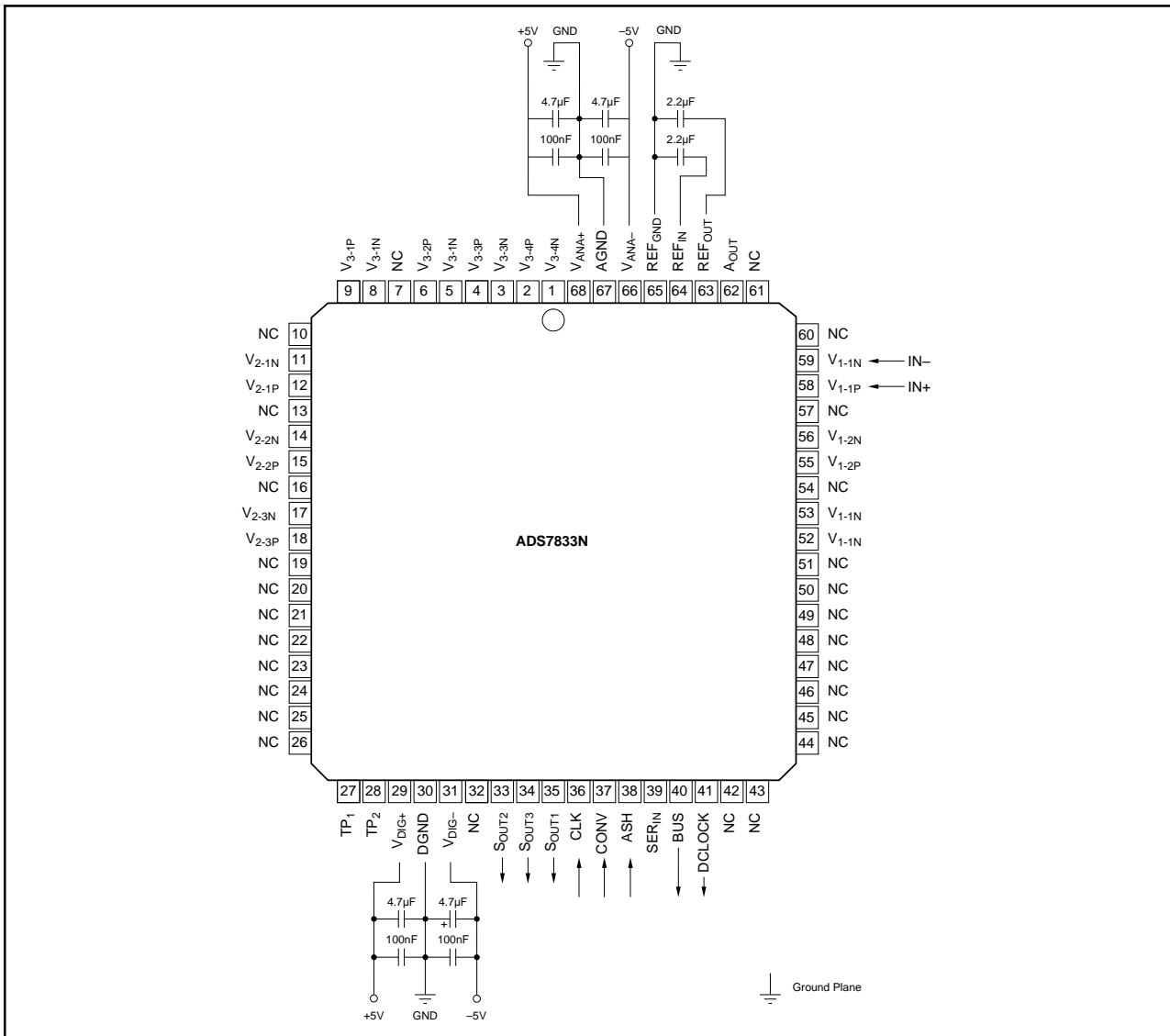

FUNCTIONAL DESCRIPTION

(See Figure 1)

ADCs AND PGAs

The ADS7833 contains three signal channels each with a 12-bit analog-to-digital converter output. The ADCs operate synchronously and their serial outputs occur simultaneously. (Table VI gives the analog input/digital output relation-

ships). The ADCs are preceded by programmable gain amplifiers. (Table II gives gain select information). For channels one and two, the PGAs are effective for all three analog inputs. For the third channel, only the V_{3-1} input is gain changed by the PGA. Inputs V_{3-2} , V_{3-3} , and V_{3-4} are connected to ADC_3 at a fixed gain of 1V/V regardless of the Gain Select value.

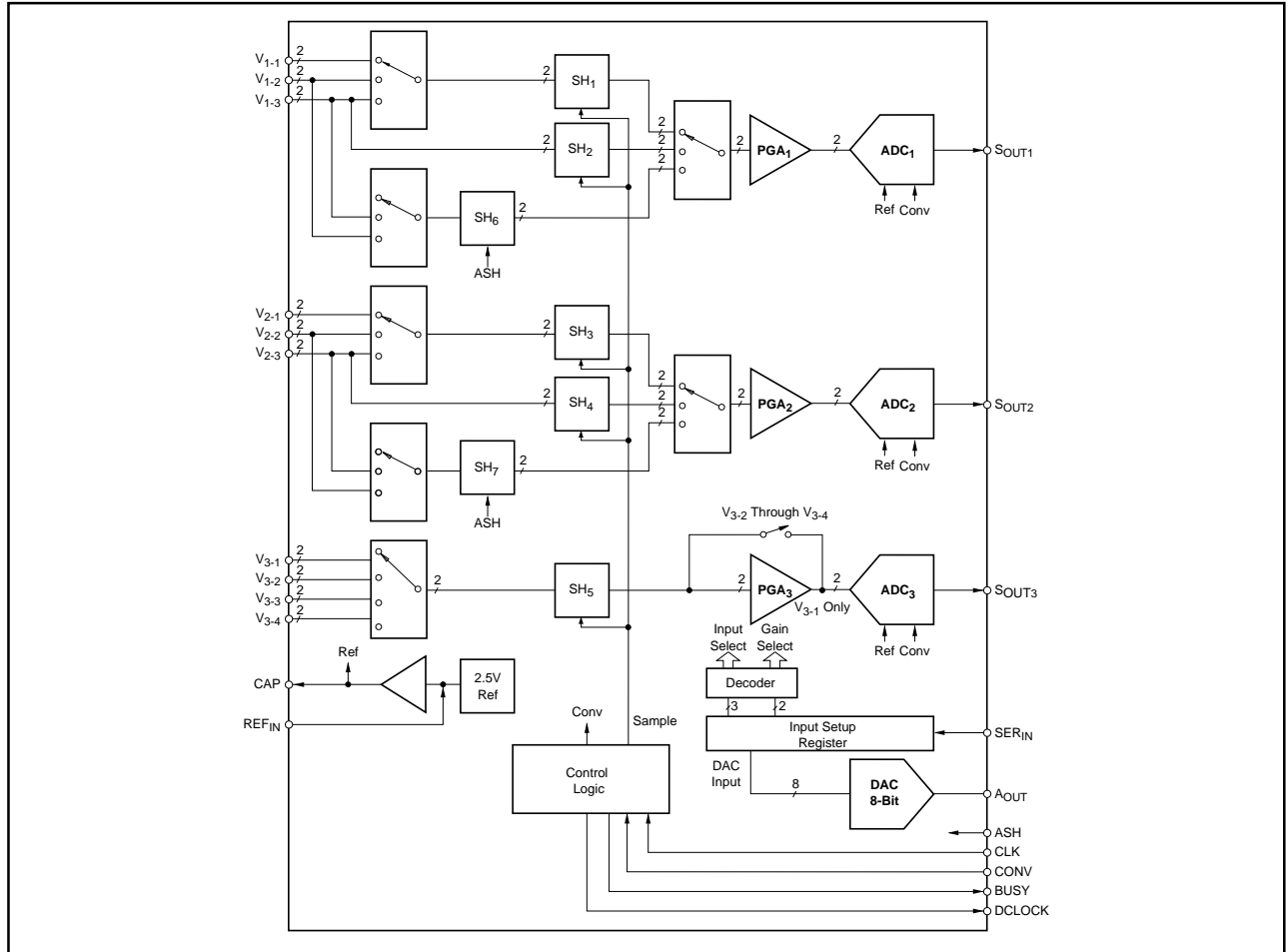

FIGURE 1. Functional Diagram.

SAMPLE HOLDS

The ADS7833 contains seven sample holds. Five of them (SH_1 through SH_5) sample simultaneously and have their sample/hold timing internally synchronized. (The timing is shown in Figure 2).

Three of the sample holds (SH_1 , SH_3 , and SH_5) are connected to the input multiplexers so that they can provide simultaneous sampling for all of their channels inputs. In addition, SH_2 and SH_4 simultaneously sample the third input of their channels (V_{1-3} and V_{2-3} , respectively). This is useful in motor control applications where V_{1-2} and V_{1-3} are the quadrature inputs for one position sensor, and V_{2-2} and V_{2-3} are the quadrature inputs for a second position sensor (see Figure 6). In that application, it is desirable to sample

the quadrature inputs of a given position sensor at the same time (even though they are converted on successive conversion cycles) (see Table III), so that their values are captured at the same shaft position.

The ADS7833 also has the capability for limited asynchronous sampling. The sampling of SH_6 and SH_7 is controlled asynchronously by the control signal ASH (see Table III). This allows two inputs each on channel 1 and channel 2 (see Table IV) to be sampled asynchronously from the timing of the other sample holds. This can be useful in motor control applications where the two inputs for each channel come from a position sensor and it is desired to sample based on position sensor timing rather than system clock timing.

MULTIPLEXERS

The ADS7833 also contains several multiplexers that are used to select the desired analog inputs and connect the proper sample hold outputs to the PGAs and ADCs. The MUXs are driven by a decoder which receives its inputs from the Input Setup Register. (See Table III and Table IV for information on input channel selection). The input multiplexers can take full differential input signals (see Figure 3 and Table VII). The analog signals stay differential through the sample holds and the PGAs all the way to the inputs of the ADSs. This is done to provide the best possible high frequency noise rejection.

INPUT SETUP

As the ADCs are converting and transmitted their serial digital data for one conversion cycle, a setup word is being received to be used for the next conversion cycle. The 13-bit word is supplied at the SER_{IN} pin (see Figure 1), and is stored in the buffered Input Setup Register. The Input Select and Gain Select portions of the word are decoded and determine the state of the multiplexers and PGAs (see CONFIGURABLE PARAMETERS section).

DIGITAL-TO-ANALOG CONVERTER

An 8-bit DAC provides 256 output voltage levels from 0V to 2.5V (see Table V for input/output relationships). The DAC is controlled by the DAC Input portion of the input setup word. The DAC Input portion of the word is strobed into the DAC at the end of the conversion cycle (14th CLK pulse in Figure 2).

VOLTAGE REFERENCE

The ADS7833 contains an internal 2.5V voltage reference. It is available externally through an output buffer amplifier. If it is desired to use an external reference, one may be

connected at the REF_{IN} pins. This then overrides the internal 2.5V reference, is connected to the ADCs and is available buffered at the CAP pin.

OTHER DIGITAL INPUTS AND OUTPUTS

Sampling and conversion is controlled by the CONV input (see Figure 2). The ADS7833 is designed to operate from an external clock supplied at the CLK input. This allows the conversion to be done synchronously with system timing so that transient noise effects can be minimized. The CLK signal may run continuously or may be supplied only during convert sequences. The BUSY and DCLOCK signals are internally generated and are supplied to make interfaces with microprocessors easier (see Figures 2, 4, and 6).

CONFIGURABLE PARAMETERS

Configurable parameters are:

- PGA Gain
- Input multiplexer and sample/hold selection
- DAC output voltage

Configuration information for these parameters is contained in the SER_{IN} word (See Figure 2). As one conversion is taking place, the configuration for the next conversion is being loaded into the buffered Input Setup Register via the SER_{IN} word. Table I shows information regarding these parameters.

CLOCK POSITIONS ⁽¹⁾	DESCRIPTION	FUNCTIONS
2-9	DAC Input ₀₋₇	Sets DAC Output Voltage
10-11	Gain Select ₀₋₁	Sets PGA Gains
12-14	Input Select ₀₋₂	Determines Multiplexers Conditions

NOTE: (1) See Figure 2. "Clock Pulse Reference No."

TABLE I. Description of Configurable Parameters.

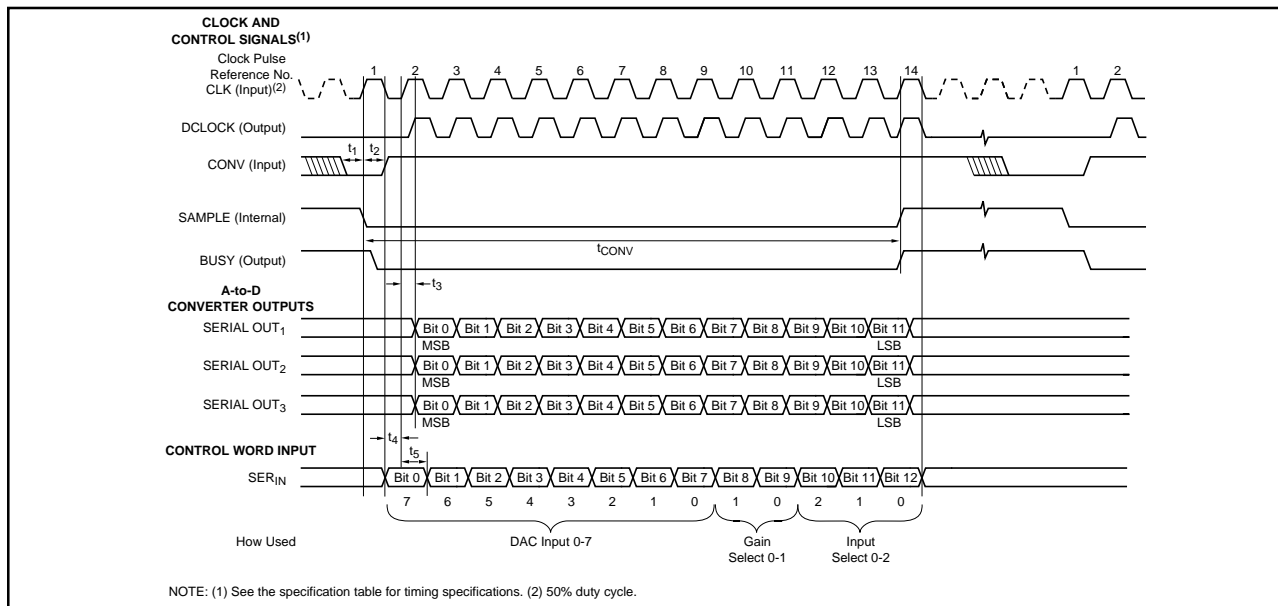

FIGURE 2. Timing Diagram.

PGA GAIN

The PGA gain is determined by the Gain Select portion (bits 8 and 9) in the SER_{IN} word (see Figure 2). There is one gain input that sets the same gain for all three PGAs. The gain values and allowable full scale inputs are shown in Table II.

For channels one and two the PGAs set the gain for all three analog inputs. For the third channel, only the V₃₋₁ input is gain changed by the PGA. Inputs V₃₋₂, V₃₋₃ and V₃₋₄ are connected to ADC₃ at a fixed gain of 1V/V regardless of the Gain Select value.

GAIN SELECT ₀₋₁	GAIN SETTING	FULL SCALE INPUT
0 _H	5.0V/V	±0.5V
1 _H	2.5V/V	±1.0V
2 _H	1.25V/V	±2.0V
3 _H	1.0V/V	±2.5V

TABLE II. Gain Select Information.

INPUT MULTIPLEXER AND SAMPLE HOLD SELECTION

The Input Select portion of the SER_{IN} word (bits 10, 11 and 12) (see Figure 2) are decoded and determine the open/closed condition of the multiplexer switches. This in turn determines which input signals are connected to the sample holds and which sample holds are connected to the PGAs/ADCs.

INPUT SIGNALS FOR PGAs/ADCs

Table III shows the relationships between the value of Input Select₀₋₂ and the signals that are converted.

INPUT SELECT ₀₋₂		ANALOG SIGNAL CONNECTED TO PGA _x /ADC _x		
HEX CODE	BINARY CODE	PGA ₁ /ADC ₁	PGA ₂ /ADC ₂	PGA ₃ /ADC ₂
0 _H	000	Undefined	Undefined	V ₃₋₄
1 _H	001	V _{1-x} via SH ₆ ⁽¹⁾	V _{2-x} via SH ₇ ⁽¹⁾	V ₃₋₄
2 _H	010	V ₁₋₃ via SH ₁	V ₂₋₃ via SH ₃	V ₃₋₃
3 _H	011	V ₁₋₃ via SH ₂	V ₂₋₃ via SH ₄	V ₃₋₃
4 _H	100	V ₁₋₂	V ₂₋₂	V ₃₋₂
5 _H	101	V ₁₋₂	V ₂₋₂	V ₃₋₂
6 _H	110	V ₁₋₂	V ₂₋₂	V ₃₋₂
7 _H	111	V ₁₋₁	V ₂₋₁	V ₃₋₁

NOTE: (1) See Table IV for Operation.

TABLE III. Input Controls for Synchronous Sample Holds.

Input Select = 7_H—Synchronously sample and convert input signals V₁₋₁, V₂₋₁, and V₃₋₁.

Input Select = 4_H, 5_H, 6_H—Synchronously sample and convert input signals V₁₋₂, V₂₋₂, and V₃₋₂. These codes also cause SH₂ and SH₄ to sample their inputs. Values 4_H, 5_H, 6_H have different effects on the inputs to SH₆ and SH₇ (see Table IV).

Input Select = 3_H—Convert V₁₋₃ via SH₂, V₂₋₃ via SH₄, and V₃₋₃ (V₁₋₃ and V₂₋₃ are from the value sampled in a preceding conversion cycle with Input Select = 4_H, 5_H or 6_H).

Input Select = 2_H—Convert V₁₋₃ via SH₁, V₂₋₃ via SH₃, and V₃₋₃ (V₁₋₃ is sampled on SH₂ in this conversion cycle).

Input Select = 1_H—Input V₃₋₄ is converted by PGA₃/ADC₃. The output of the asynchronous sample holds, SH₆ and SH₇, are converted by PGA₁/ADC₁ and PGA₂/ADC₂, respectively. Note that the inputs to SH₆ and SH₇ are determined by previous Input Select values (see Table IV). Thus, to properly convert the output of one of the asynchronous sample holds it is first necessary to choose its input with a previous conversion cycle. Also, the output of SH₆ or SH₇ will only be converted if ASH goes low before the CONV command is received.

Input Select = 0_H—V₃₋₄ is converted by PGA₃/ADC₃. The inputs to PGA₁/ADC₁ and PGA₂/ADC₂ are undefined.

CONVERSIONS FROM THE ASYNCHRONOUS SAMPLE HOLDS

Decoding the Input Select value also determines which inputs are applied to the two asynchronously controlled sample holds SH₆ and SH₇. (See Table IV.) One of the three possible inputs is selected by the Input Select value being 4, 5, or 6.

The “No Effect” states indicate that these values of Input Select have no effect on the multiplexers at the input of SH₆ and SH₇. When one of the “No Effect” values of Input Select is presented, the multiplexers will not be changed (i.e., their condition is determined by the last 4, 5, or 6 value of Input Select that existed prior to the “No Effect” state).

Note that Input Select = 1_H presents the output of SH₆ and SH₇ (1ASH_x and 2ASH_x) to PGA₁/ADC₁ and PGA₂/ADC₂, respectively (see Table III). Therefore, in order to properly convert the asynchronous sampled signals, it is first necessary to choose an input signal (Input Select equal 5 or 6 in Table IV) with one load/convert cycle and then convert the sample hold output (Input Select = 4 in Table III) in a following conversion cycle.

INPUT SELECT ₀₋₂		ANALOG SIGNAL CONNECTED TO	
HEX CODE	BINARY CODE	SH ₆	SH ₇
0 _H	000	No Effect	No Effect
1 _H	001	No Effect	No Effect
2 _H	010	No Effect	No Effect
3 _H	011	No Effect	No Effect
4 _H	100	Open	Open
5 _H	101	V ₁₋₃	V ₂₋₃
6 _H	110	V ₁₋₂	V ₁₋₂
7 _H	111	No Effect	No Effect

TABLE IV. Input Controls for Asynchronous Sample Holds.

DAC OUTPUT VOLTAGE

The value of the DAC output voltage is determined by the DAC Input portion of the SER_{IN} word (bits 0 through 7—see Figure 2). The 8-bit DAC has 256 possible output voltages from 0V to +2.49V. The value of 1 LSB is 0.0098V.

ANALOG-TO-DIGITAL CONVERTERS

ARCHITECTURE

The ADCs are 12-bit, successive approximation types implemented with a switched capacitor circuitry.

SPEED

The clock for the ADC conversion is supplied externally at the CLK pin. Maximum clock frequency for specified accuracy is 2.1MHz. This results in a complete conversion cycle (S/H acquisition and A/D conversion) of 6.6 μ s.

INPUT/OUTPUT

The ADS7833 is designed for bipolar input voltages and uses a binary two's complement digital output code. A programmable gain function is associated with each ADC. This changes the full scale analog input range and the analog resolution of the converter. Details are shown in Table VI.

DIFFERENTIAL AND COMMON-MODE INPUT VOLTAGES

The ADS7833 is designed with full differential signal paths all the way from the multiplexer inputs through to the input of the ADCs. This was done to provide superior high frequency noise rejection.

DIGITAL INPUT DAC INPUT ₀₋₇		ANALOG OUTPUT
HEX CODE	BINARY CODE	
00 _H	0000 0000	0V
01 _H	0000 0001	+0.0098V
⋮	⋮	⋮
⋮	⋮	⋮
FF _H	1111 1111	+2.499

TABLE V. DAC Input/Output Relationships.

DESCRIPTION	ANALOG INPUT				DIGITAL OUTPUT	
	0	1	2	3	BINARY TWO'S COMPLIMENT FORMAT	
GAIN SELECT CODE	0	1	2	3	HEX CODE	BINARY CODE
GAIN	5V/V	2.5V/V	1.25V/V	1.0V/V	7FF _H	0111 1111 1111
FULL SCALE RANGE	$\pm 0.5V$	$\pm 1.0V$	$\pm 2.0V$	$\pm 2.5V$	001 _H	0000 0000 0001
+Full Scale (FS -1LSB)	+0.49976	+0.9995V	+1.999V	+2.499	000 _H	0000 0000 0000
One Bit above Mid-Scale	+0.244mV	+0.488mV	+0.976mV	+1.22mV	FFF _H	1111 1111 1111
Mid-Scale	0V	0V	0V	0V	800 _H	1000 0000 0000
One Bit Below Mid-Scale	-0.244V	-0.488mV	-0.976mV	-1.22mV		
-Full Scale	-0.500V	-1.000V	-2.000V	-2.500V		

NOTE: The programmable gain function applies to all three input channels for ADC₁ and ADC₂. However, the programmable gain function only applies to the first input (V_{3-1}) for ADC₃. The other three inputs (V_{3-2} , V_{3-3} , and V_{3-4}) are not affected by the GAIN SEL input. They operate at a fixed gain of 1V/V and thus have a fixed $\pm 2.5V$ full scale input range.

TABLE VI. Analog Input - Digital Output Relationships.

As is common with most differential input semiconductor devices, there are compound restrictions on the combination of differential and common-mode input voltages. This matter is made slightly more complicated by the fact that most of the analog inputs are capable of being affected by the programmable gain function. The possible differential and single ended configurations are shown in Figures 3a and 3b. The maximum differential and common mode restrictions are shown in Table VII.

GAIN SELECT CODE	0	1	2	3
Gain	5.0V/V	2.5V/V	1.25V/V	1.0V/V
Full Scale Range (V_D with $V_{CM} = 0$)	$\pm 0.5V$	$\pm 1.0V$	$\pm 2.0V$	$\pm 2.5V$
Largest Positive Common Mode Voltage, V_{CM+}	+2.7V	+2.4V	+1.9V	+1.6V
Largest Negative Common Mode Voltage, V_{CM-}	-2.7V	-2.4V	-1.9V	-1.6V

TABLE VII. Differential and Common Mode Voltage Restrictions.

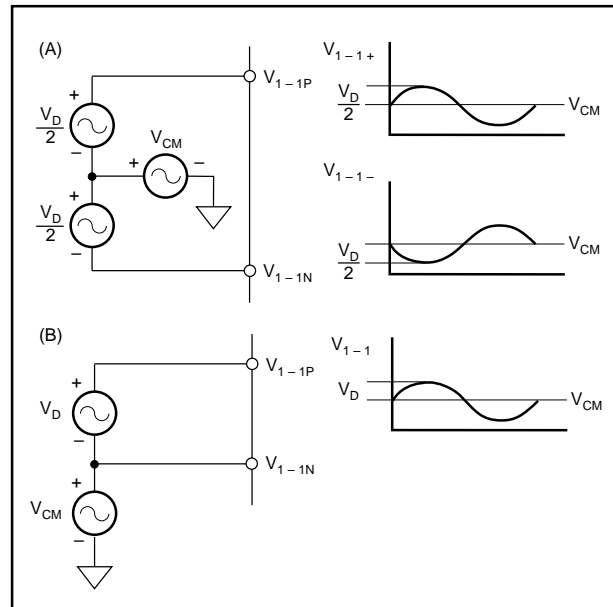

FIGURE 3. (a) Differential Signal Source, and (b) Single Ended Signal Source.

MICROPROCESSOR INTERFACE

The internal logic of the ADS7833 is designed for easy control and data interface with microprocessors. Figure 4 shows the interface for loading the input control word from the microprocessor data bus into the serial input of the ADS7833.

Table VIII provides a sample assembly code and Figure 4 shows the connection diagram for connecting an ADS7833 to the DSP56004N—or DSP56007 a Motorola Digital Signal Processor. This configuration allows for full control of the ADS7833 as well as receiving all three conversion results simultaneously. The start of conversion is generated by the DSP56004 as well as the sample time of the asynchronous sample/holds.

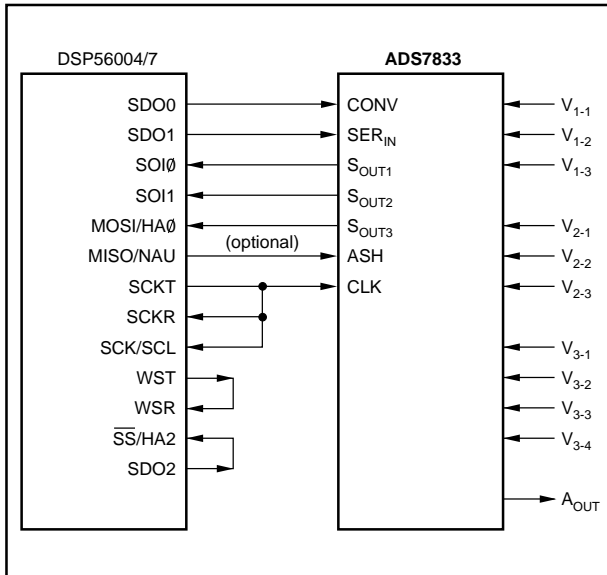

FIGURE 4. Microprocessor Interface for Motorola DSP56004/7.

movep	#>\$0,x:\$ffe4	; Disable SAI transmit port
movep	#>\$0,x:\$ffe1	; Disable SAI receive port
movep	#>\$0,x:\$fff1	; Disable SHI port
	;	
movep	#>\$dfff0,x:\$ffe5	; Convert command
movep	#>\$101f00,x:\$ffe6	; DAC to midscale, G=1V/V, Channel 1 all ADCs
movep	#>\$0,x:\$ffe7	; For SS pin-enables SHI at proper time
movep	#>\$10d,x:\$ffe0	; Divide by 1 pre, divide by 13-96kHz conv @ 40MHz
movep	#>\$3,x:\$ffe1	; Enable SAI recv (rsng edge, MSB 1st, 16-bits, slave)
movep	#>\$2001,x:\$fff0	; Set narrow spike filter, CPOL=0, CPHA=1
movep	#>\$5,x:\$fff1	; Enable SHI (slave, no fifo, 16-bits)
movep	#>\$f,x:\$ffe4	; Enable SAI trans (rsng edge, MSB 1st, 16-bits, mstr)
	;	
wait	btst #14,x:\$ffe1	; Look for a receive flag (left or right)
	jcs data	
	btst #15,x:\$ffe1	
	jcc wait	
data	movep x:\$ffe2,x0	; Get Sout1
	move x0,x:\$00	; Save it
	movep x:\$ffe3,x0	; Get Sout2
	move x0,x:\$01	; Save it
	move x:\$ff3,x0	; Get Sout3
	movep x0,x:\$02	; Save it

TABLE VIII. Sample Code for Motorola DSP56004/7.

While this is one of the most useful, the DSP56004/7 is flexible enough to allow various other configurations. These will free up the serial outputs for use with other serial peripherals, such as DACs.

TYPICAL ISOLATED ANALOG INPUT

Figure 5 shows an ISO130 used to isolate the current measurement in a motor speed control application. This amplifier is well suited for this application because of its high transient immunity (10kV/μs). Its differential output feature is well suited to the differential input of the ADS7833. Keeping the signal transmission differential helps to preserve the high frequency noise rejection of the system.

A unique characteristic of the ISO130 is that it has a common mode output voltage of approximately 2.39V. To accept this level of CMV, the ADS7833 must be operated at a gain of 5V/V (±0.5V full scale differential input). (See Figure 3 and Table VII). Since the ISO130 has a gain of 8V/V, the maximum value of V_{SENSE} is 62.5mV. Thus, the value of R_{SENSE} is chosen to scale V_{SENSE} to this maximum value.

POWER-UP INITIALIZATION

When power is applied to the ADS7833, two conversion cycles are required for initialization and valid digital data is transmitted on the third cycle.

The first conversion after power is applied is performed with indeterminate configuration values in the double buffer output of the Input Setup Register. The second conversion cycle loads the desired values into the register. The third conversion uses those values to perform proper conversions and output valid digital data from each of the ADCs.

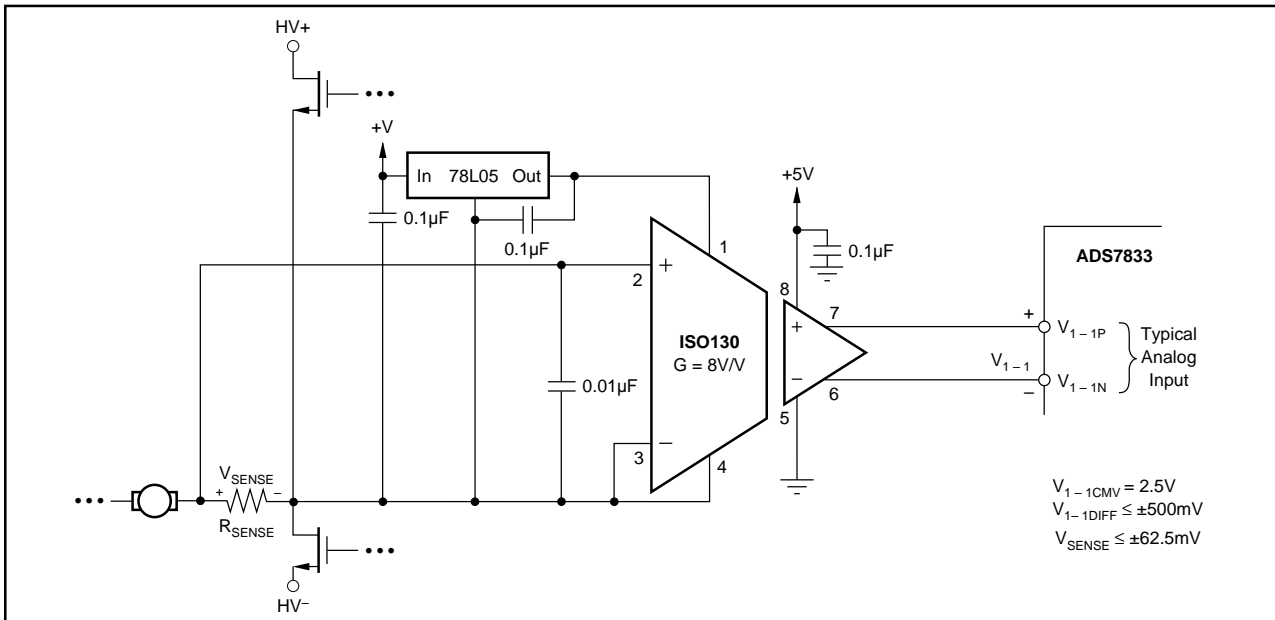

FIGURE 5. Typical Isolated Differential Analog Input.

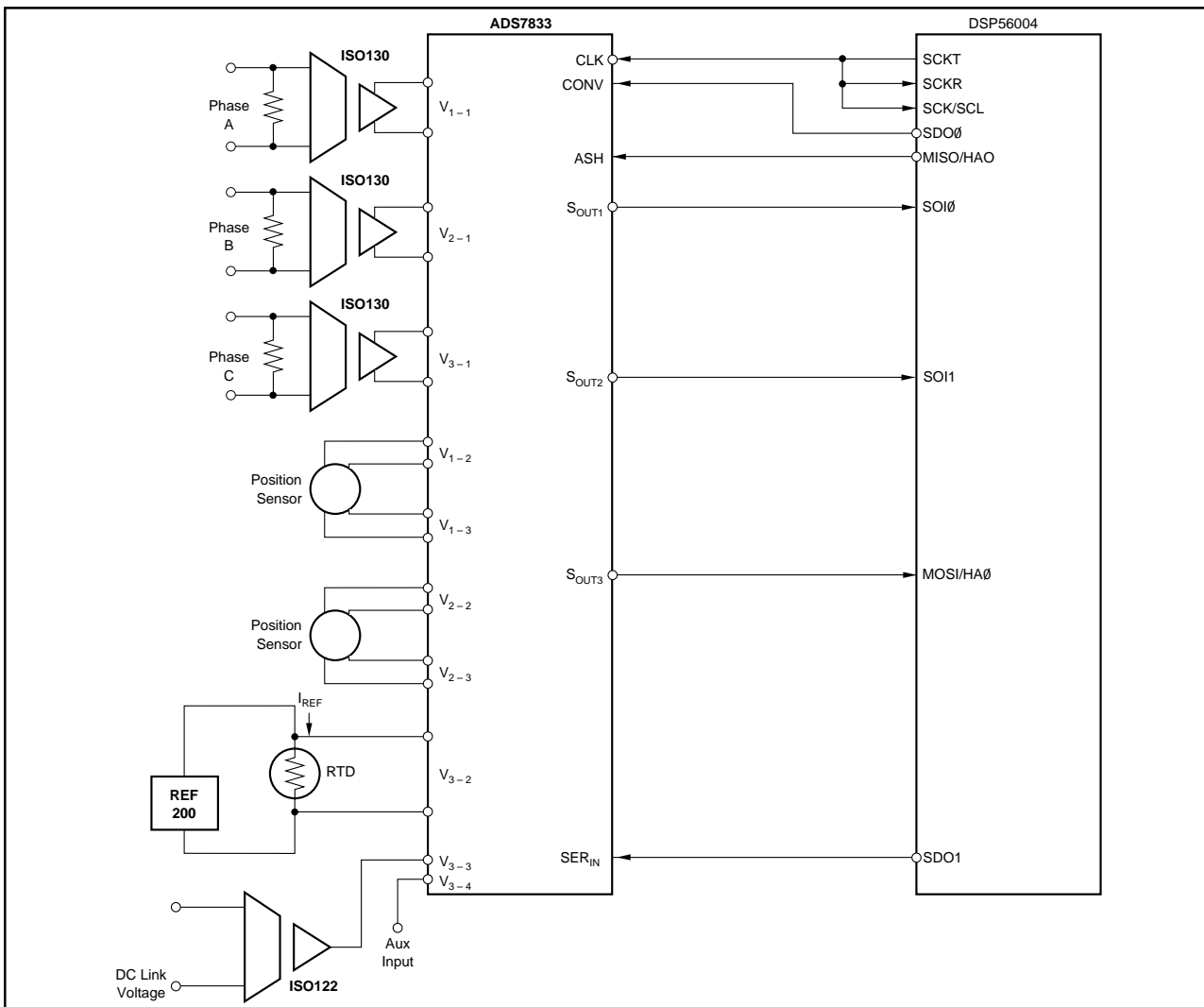

FIGURE 6. Motor Control Application Using Position Sensors.