



# 12-Bit Capacitance-to-Digital Converter

## AD7152/AD7153

### FEATURES

- Capacitance-to-digital converters
- Interfaces to floating sensors
- Resolution down to 0.25 fF (that is, up to 12 ENOB)
- Linearity: 0.05%
- Common-mode (not changing) capacitance up to 5 pF
- Four capacitance ranges selectable per operation mode
  - ±0.25 pF to ±2 pF in differential mode
  - 0.5 pF to 4 pF in single-ended mode
- Tolerant of parasitic capacitance to ground up to 50 pF
- Conversion time per channel: 5 ms, 20 ms, 50 ms, and 60 ms
- Internal clock oscillator
- 2-wire serial interface (I<sup>2</sup>C-compatible)
- Power
  - 2.7 V to 3.6 V single-supply operation
  - 100 μA current consumption
- Operating temperature: -40°C to +85°C
- 10-lead MSOP package

### APPLICATIONS

- Automotive, industrial, and medical systems for
  - Pressure measurement
  - Position sensing
  - Level sensing
  - Flowmeters
  - Humidity sensing

### GENERAL DESCRIPTION

The AD7152/AD7153 are 12-bit sigma-delta ( $\Sigma$ - $\Delta$ ) capacitance-to-digital converters (CDCs). The capacitance to be measured is connected directly to the device inputs. The architecture features inherent high resolution (12-bit no missing codes, up to 12-bit effective resolution) and high linearity ( $\pm 0.05\%$ ). The AD7152/AD7153 have four capacitance input ranges per operation mode,  $\pm 0.25$  pF to  $\pm 2$  pF in differential mode and 0.5 pF to 4 pF in single-ended mode.

The AD7152/AD7153 can accept up to 5 pF common-mode capacitance (not changing), which can be balanced by a programmable on-chip, digital-to-capacitance converter (CAPDAC).

The AD7153 has one capacitance input channel, while the AD7152 has two channels. Each channel can be configured as single-ended or differential. The AD7152/AD7153 are designed for floating capacitive sensors.

The AD7152/AD7153 have a 2-wire, I<sup>2</sup>C<sup>®</sup>-compatible serial interface. Both parts can operate with a single power supply from 2.7 V to 3.6 V. They are specified over the temperature range of -40°C to +85°C and are available in a 10-lead MSOP package.

### FUNCTIONAL BLOCK DIAGRAMS

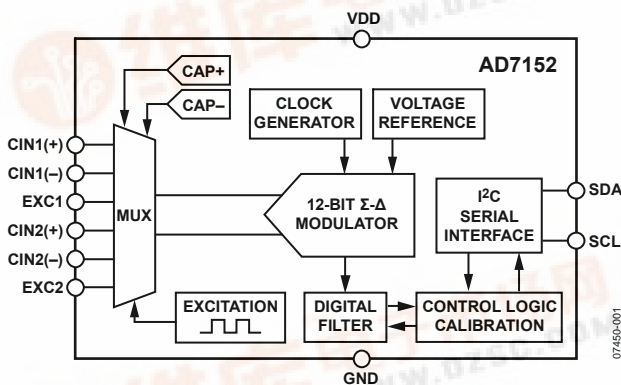

Figure 1.

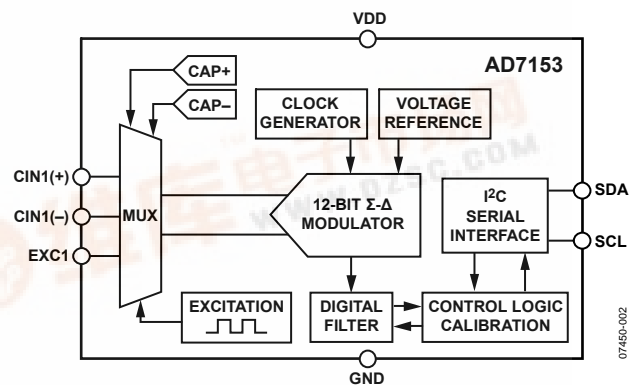

Figure 2.



# AD7152/AD7153

## TABLE OF CONTENTS

Features .....	1	Configuration Register .....	16
Applications.....	1	CAPDAC POS Register .....	17
General Description .....	1	CAPDAC NEG Register .....	17
Functional Block Diagrams.....	1	Configuration2 Register .....	17
Revision History .....	2	Circuit Description.....	18
Specifications.....	3	Capacitance-to-Digital Converter (CDC) .....	18
Timing Specifications .....	5	Excitation Source.....	18
Absolute Maximum Ratings.....	6	CAPDAC .....	19
ESD Caution.....	6	Single-Ended Capacitive Input.....	19
Pin Configurations and Function Descriptions .....	7	Differential Capacitive Input .....	20
Typical Performance Characteristics .....	8	Parasitic Capacitance to Ground.....	20
Serial Interface .....	11	Parasitic Resistance to Ground.....	20
Write Operation.....	11	Parasitic Parallel Resistance .....	21
Read Operation.....	11	Parasitic Serial Resistance .....	21
AD7152/AD7153 Reset .....	12	Input EMC Protection .....	21
General Call.....	12	Power Supply Decoupling and Filtering.....	21
Register Map.....	13	Capacitive Gain Calibration .....	21
Status Register .....	14	Capacitive System Offset Calibration .....	21
Data Registers .....	15	Typical Application Diagram.....	22
Offset Calibration Registers .....	15	Outline Dimensions .....	23
Gain Calibration Registers .....	15	Ordering Guide .....	23
CAP Setup Registers .....	16		

## REVISION HISTORY

5/08—Revision 0: Initial Version

## SPECIFICATIONS

$V_{DD} = 2.7\text{ V to }3.6\text{ V}$ ;  $GND = 0\text{ V}$ ;  $-40^{\circ}\text{C to }+85^{\circ}\text{C}$ , unless otherwise noted.

**Table 1.**

Parameter	Min	Typ	Max	Unit <sup>1</sup>	Test Conditions/Comments
<b>CAPACITIVE INPUT</b>					
Capacitive Input Ranges		$\pm 2$		pF	Differential mode
		$\pm 1$		pF	
		$\pm 0.5$		pF	
		$\pm 0.25$		pF	Single-ended mode
		4		pF	
		2		pF	
		1		pF	
Gain Matching Between Ranges			$\pm 3$	% of FS	
Integral Nonlinearity (INL) <sup>2</sup>		$\pm 0.05$		% of FS	
No Missing Codes <sup>2</sup>	12			Bits	
Resolution, p-p <sup>2,3</sup>		10		Bits	25°C, $V_{DD} = 3.3\text{ V}$ , 4 pF range
Resolution Effective <sup>2,3</sup>		12		Bits	25°C, $V_{DD} = 3.3\text{ V}$ , 4 pF range
Absolute Error <sup>4</sup>			$\pm 20$	ff	25°C, $V_{DD} = 3.3\text{ V}$ , after system offset calibration, $\pm 2\text{ pF}$ range
System Offset Calibration Range <sup>5,6</sup>			40	% of FSR	
Offset Deviation over Temperature <sup>2</sup>		1	5	ff	Single-ended mode, CIN and EXC pins disconnected, see Figure 8
		0.3	1	ff	Differential mode, CIN and EXC pins disconnected
Gain Error <sup>7</sup>			0.5	% of FSR	25°C, $V_{DD} = 3.3\text{ V}$
Gain Deviation over Temperature <sup>2</sup>		0.3	0.4	% of FSR	See Figure 7
Allowed Capacitance, CIN to GND <sup>2</sup>			50	pF	See Figure 9 and Figure 10
Allowed Resistance, CIN to GND <sup>2</sup>			10	M $\Omega$	See Figure 13
Allowed Serial Resistance <sup>2</sup>			20	k $\Omega$	See Figure 16
Power Supply Rejection DC		2		ff/V	See Figure 17
Normal-Mode Rejection <sup>2</sup>		-70		dB	50 Hz $\pm 1\text{ Hz}$ , conversion time = 60 ms
		-70		dB	60 Hz $\pm 1\text{ Hz}$ , conversion time = 50 ms
Channel-to-Channel Isolation <sup>2</sup>		-70		dB	AD7152 only
<b>CAPDAC</b>					
Full Range	5	6.25		pF	5-bit CAPDAC See Figure 18 and Figure 19 Single-ended mode
Resolution <sup>8</sup>		200		ff	
Differential Nonlinearity (DNL) <sup>2</sup>			0.25	LSB	
Offset Deviation over Temperature <sup>2</sup>		0.3		% of CAPDAC FSR	
<b>EXCITATION</b>					
Frequency	30.9	32	32.8	kHz	See Figure 11 and Figure 12
Voltage		$\pm V_{DD}/2$		V	
Allowed Capacitance, EXC to GND <sup>2</sup>			300	pF	
<b>SERIAL INTERFACE LOGIC INPUTS (SCL, SDA)</b>					
Input High Voltage, $V_{IH}$	1.5			V	
Input Low Voltage, $V_{IL}$			0.8	V	
Input Leakage Current (SCL)		$\pm 0.1$	$\pm 5$	$\mu\text{A}$	
<b>OPEN-DRAIN OUTPUT (SDA)</b>					
Output Low Voltage, $V_{OL}$			0.4	V	$I_{SINK} = -6.0\text{ mA}$ $V_{OUT} = V_{DD}$
Output High Leakage Current, $I_{OH}$		0.1	5	$\mu\text{A}$	
<b>POWER SUPPLY MONITOR</b>					
Threshold Voltage, $V_{DD}$		2.45	2.65	V	

# AD7152/AD7153

Parameter	Min	Typ	Max	Unit <sup>1</sup>	Test Conditions/Comments
<b>POWER REQUIREMENTS</b>					
V <sub>DD</sub> -to-GND Voltage	2.7		3.6	V	V <sub>DD</sub> = 3.3 V, nominal
Current, I <sub>DD</sub> <sup>9</sup>		100	120	μA	
Current Power-Down Mode, I <sub>DD</sub> <sup>9</sup>		1	5	μA	Temperature ≤ 25°C
		3	10	μA	Temperature = 85°C

<sup>1</sup> Capacitance units: 1 pF = 10<sup>-12</sup> F; 1 fF = 10<sup>-15</sup> F; 1 aF = 10<sup>-18</sup> F.

<sup>2</sup> Specification is not production tested but is supported by characterization data at initial product release.

<sup>3</sup> Except Channel 2 in differential mode. To achieve the specified performance in differential mode, the I<sup>2</sup>C interface must be idle during the capacitance conversion to prevent signal coupling from the SCL pin to the adjacent CIN2(-) pin.

<sup>4</sup> Factory calibrated. The absolute error includes factory gain calibration error and integral nonlinearity error all at 25°C. At different temperatures, compensation for gain drift over temperature is required.

<sup>5</sup> Specification is not production tested but guaranteed by design.

<sup>6</sup> A system offset calibration is effectively a conversion; therefore, the offset error is of the order of the conversion noise. This applies after calibration at the temperature, capacitive input range, and applied V<sub>DD</sub> of interest. The capacitive input offset can be reduced using a system offset calibration. Large offsets should be removed using CAPDACs.

<sup>7</sup> The gain error is factory calibrated at 25°C. At different temperatures, compensation for gain drift over temperature is required.

<sup>8</sup> The CAPDAC resolution is five bits in the actual CAPDAC full range. Using the on-chip offset calibration or adjusting the capacitive offset calibration register can further reduce the CIN offset or the unchanging CIN component.

<sup>9</sup> Digital inputs equal to V<sub>DD</sub> or GND.

**TIMING SPECIFICATIONS**

$V_{DD} = 2.7\text{ V to }3.6\text{ V}$ ;  $GND = 0\text{ V}$ ; Input Logic 0 = 0 V; Input Logic 1 =  $V_{DD}$ ;  $-40^{\circ}\text{C to }+85^{\circ}\text{C}$ , unless otherwise noted.

**Table 2.**

Parameter	Min	Typ	Max	Unit	Test Conditions/Comments
<b>SERIAL INTERFACE<sup>1, 2</sup></b>					See Figure 3.
SCL Frequency	0		400	kHz	
SCL High Pulse Width, $t_{HIGH}$	0.6			$\mu\text{s}$	
SCL Low Pulse Width, $t_{LOW}$	1.3			$\mu\text{s}$	
SCL, SDA Rise Time, $t_R$			0.3	$\mu\text{s}$	
SCL, SDA Fall Time, $t_F$			0.3	$\mu\text{s}$	
Hold Time (Start Condition), $t_{HD;STA}$	0.6			$\mu\text{s}$	After this period, the first clock is generated.
Set-Up Time (Start Condition), $t_{SU;STA}$	0.6			$\mu\text{s}$	Relevant for repeated start condition.
Data Set-Up Time, $t_{SU;DAT}$	0.1			$\mu\text{s}$	
Setup Time (Stop Condition), $t_{SU;STO}$	0.6			$\mu\text{s}$	
Data Hold Time, $t_{HD;DAT}$ (Master)	0.01			$\mu\text{s}$	
Bus-Free Time (Between Stop and Start Conditions, $t_{BUF}$ )	1.3			$\mu\text{s}$	

<sup>1</sup> Sample tested during initial release to ensure compliance.

<sup>2</sup> All input signals are specified with input rise/fall times = 3 ns, measured between the 10% and 90% points. Timing reference points at 50% for inputs and outputs; output load = 10 pF.

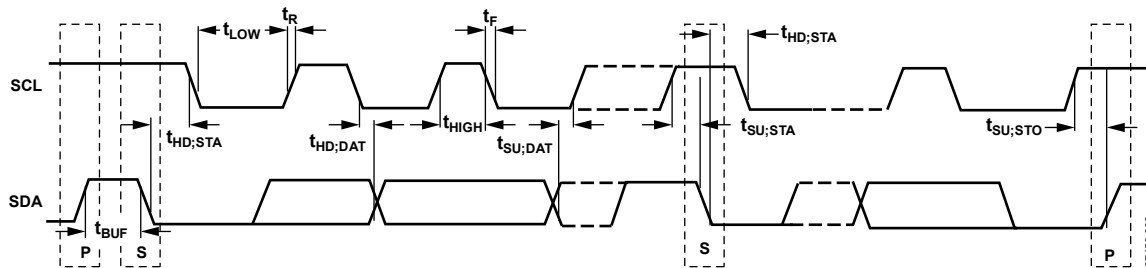

Figure 3. Serial Interface Timing Diagram

07450-013

# AD7152/AD7153

## ABSOLUTE MAXIMUM RATINGS

$T_A = 25^\circ\text{C}$ , unless otherwise noted.

Table 3.

Parameter	Rating
Positive Supply Voltage, $V_{DD}$ to GND	-0.3 V to +3.9 V
Voltage on Any Input or Output Pin to GND	-0.3 V to $V_{DD} + 0.3$ V
ESD Rating (ESD Association Human Body Model, S5.1)	4 kV
ESD Rating (Field-Induced Charged Device Model)	750 V
Operating Temperature Range	-40°C to +85°C
Storage Temperature Range	-65°C to +150°C
Junction Temperature	150°C
MSOP	
$\theta_{JA}$ Thermal Impedance-to-Air	206°C/W
$\theta_{JC}$ Thermal Impedance-to-Case	44°C/W
Reflow Soldering (Pb-Free)	
Peak Temperature	260 (+0/-5)°C
Time at Peak Temperature	10 sec to 40 sec

Stresses above those listed under Absolute Maximum Ratings may cause permanent damage to the device. This is a stress rating only; functional operation of the device at these or any other conditions above those indicated in the operational section of this specification is not implied. Exposure to absolute maximum rating conditions for extended periods may affect device reliability.

### ESD CAUTION



#### ESD (electrostatic discharge) sensitive device.

Charged devices and circuit boards can discharge without detection. Although this product features patented or proprietary protection circuitry, damage may occur on devices subjected to high energy ESD. Therefore, proper ESD precautions should be taken to avoid performance degradation or loss of functionality.

## PIN CONFIGURATIONS AND FUNCTION DESCRIPTIONS

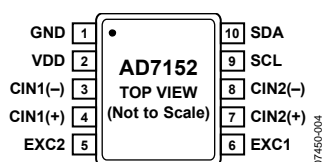

Figure 4. AD7152 Pin Configuration

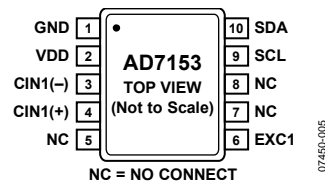

Figure 5. AD7153 Pin Configuration

Table 4. Pin Function Descriptions

Pin No.	Mnemonic	Description
1	GND	Ground Pin.
2	VDD	Power Supply Voltage. This pin should be decoupled to GND, using a low impedance capacitor, for example, in combination with a 10 $\mu$ F tantalum and a 0.1 $\mu$ F multilayer ceramic capacitor.
3	CIN1(-)	CDC Negative Capacitive Input of Channel 1. If not used, this pin can be left as an open circuit or connected to GND. This pin is internally disconnected in single-ended CDC configuration.
4	CIN1(+)	CDC Positive Capacitive Input of Channel 1. If not used, this pin can be left as an open circuit or connected to GND.
5	EXC2/NC	AD7152: CDC Excitation Output for Channel 2. The measured capacitance is connected between one of the EXC pins and one of the CIN pins. If not used, these pins should be left as an open circuit. AD7153: No Connect. This pin must be left as an open circuit.
6	EXC1	CDC Excitation Output for Channel 1. The measured capacitance is connected between one of the EXC pins and one of the CIN pins. If not used, these pins should be left as an open circuit.
7	CIN2(+)/NC	AD7152: CDC Positive Capacitive Input of Channel 2. If not used, this pin can be left as an open circuit or connected to GND. AD7153: No Connect. This pin must be left as an open circuit.
8	CIN2(-)/NC	AD7152: CDC Negative Capacitive Input of Channel 2. If not used, this pin can be left as an open circuit or connected to GND. This pin is internally disconnected in single-ended CDC configuration. AD7153: No Connect. This pin must be left as an open circuit.
9	SCL	Serial Interface Clock Input. Connects to the master clock line. Requires a pull-up resistor if one is not already provided in the system.
10	SDA	Serial Interface Bidirectional Data. Connects to the master data line. Requires a pull-up resistor if one is not provided elsewhere in the system.

TYPICAL PERFORMANCE CHARACTERISTICS

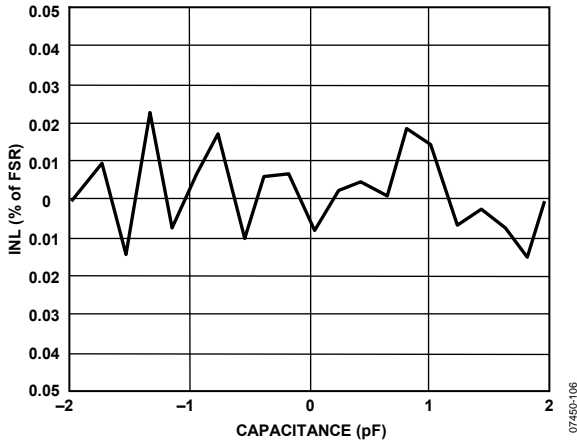

Figure 6. Capacitance Input Integral Nonlinearity,  $V_{DD} = 3.3\text{ V}$ , See Figure 34

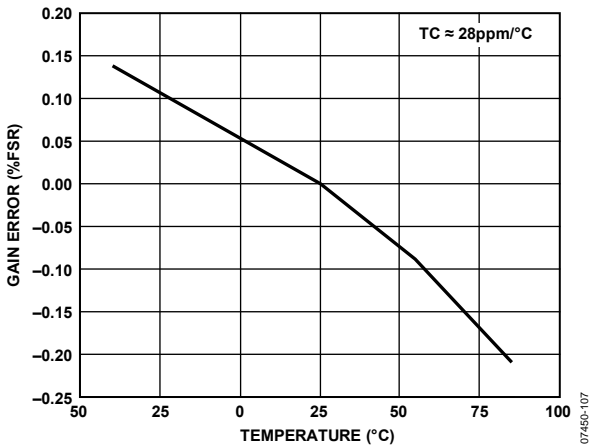

Figure 7. Capacitance Input Gain Drift vs. Temperature,  $V_{DD} = 3.3\text{ V}$ , Range =  $\pm 2\text{ pF}$

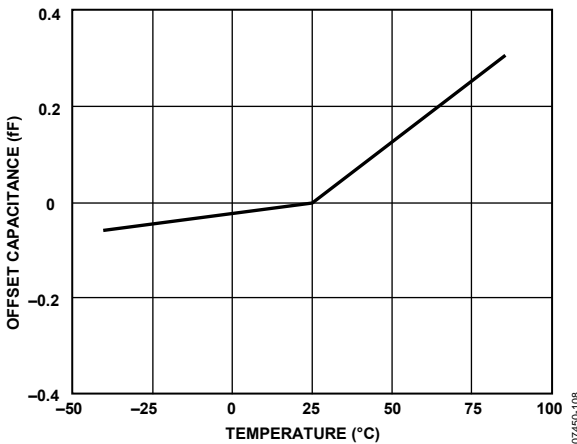

Figure 8. Capacitance Input Offset Drift vs. Temperature,  $V_{DD} = 3.3\text{ V}$ , CIN and EXC Pins Open Circuit

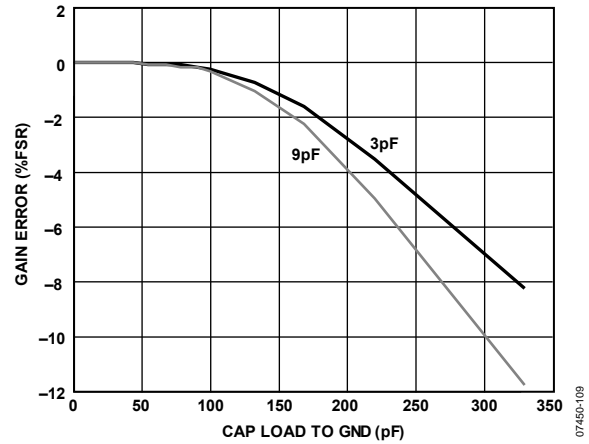

Figure 9. Capacitance Input Error vs. Capacitance Between CIN and GND; Single-Ended Mode, CIN(+) to EXC = 3 pF and 9 pF,  $V_{DD} = 3.3\text{ V}$

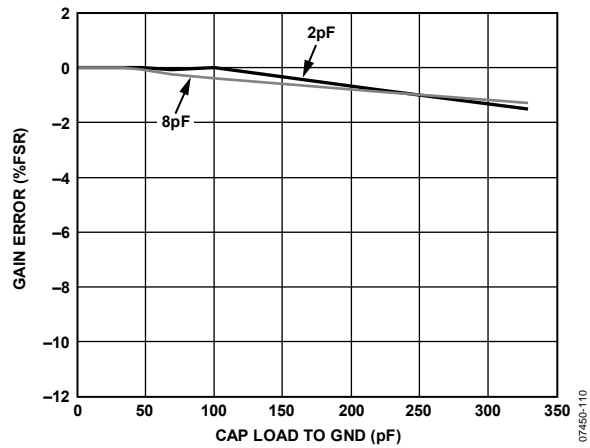

Figure 10. Capacitance Input Error vs. Capacitance Between CIN and GND, Differential Mode, CIN(+) to EXC = 2 pF and 8 pF, CIN(-) to EXC = 0 pF and 6 pF,  $V_{DD} = 3.3\text{ V}$

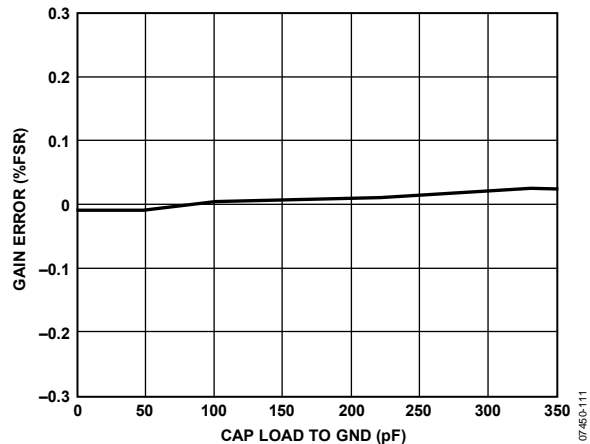

Figure 11. Capacitance Input Error vs. Capacitance Between EXC and GND, Single-Ended Mode, CIN(+) to EXC = 9 pF,  $V_{DD} = 3.3\text{ V}$



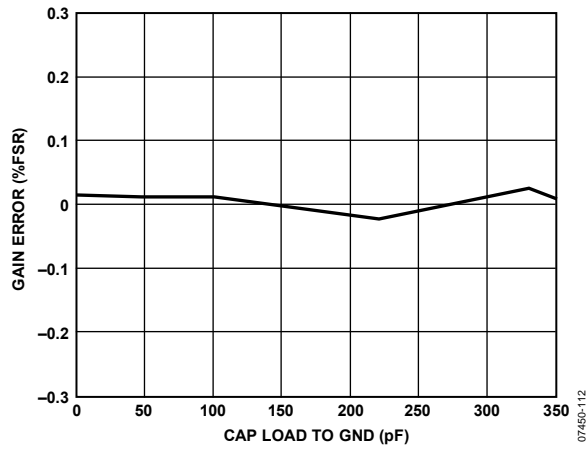

Figure 12. Capacitance Input Error vs. Capacitance Between EXC and GND, Differential Mode,  $C_{IN(+)} \text{ to EXC} = 8 \text{ pF}$ ,  $C_{IN(-)} \text{ to EXC} = 6 \text{ pF}$ ,  $V_{DD} = 3.3 \text{ V}$

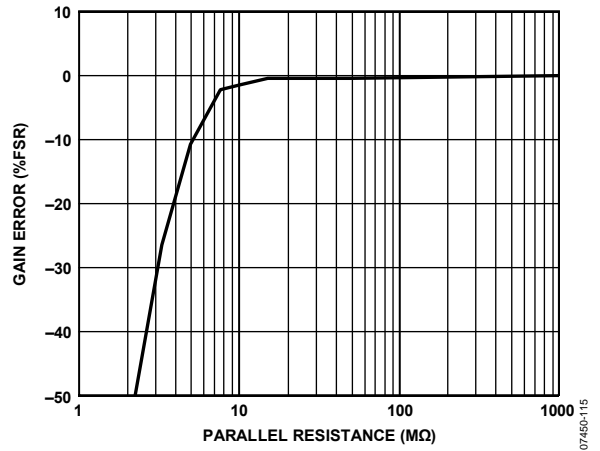

Figure 15. Capacitance Input Error vs. Parasitic Parallel Resistance Single-Ended Mode,  $C_{IN(+)} \text{ to EXC} = 9 \text{ pF}$ ,  $V_{DD} = 3.3 \text{ V}$

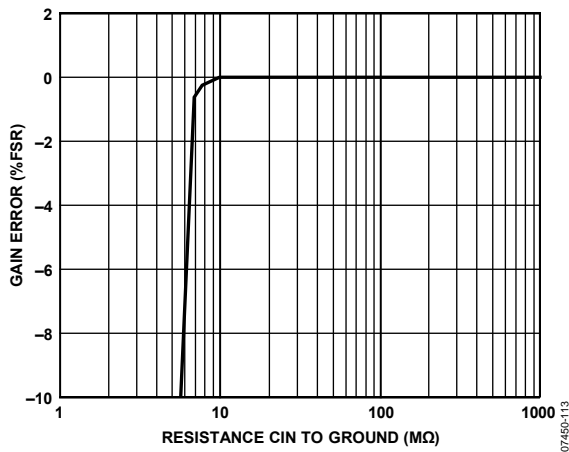

Figure 13. Capacitance Input Error vs. Parasitic Resistance  $C_{IN}$  to GND, Single-Ended Mode,  $C_{IN(+)} \text{ to EXC} = 9 \text{ pF}$ ,  $V_{DD} = 3.3 \text{ V}$

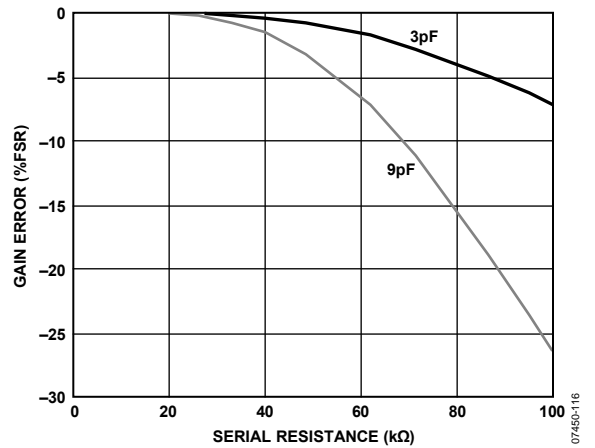

Figure 16. Capacitance Input Error vs. Serial Resistance, Single-Ended Mode,  $C_{IN(+)} \text{ to EXC} = 3 \text{ pF}$  and  $9 \text{ pF}$ ,  $V_{DD} = 3.3 \text{ V}$

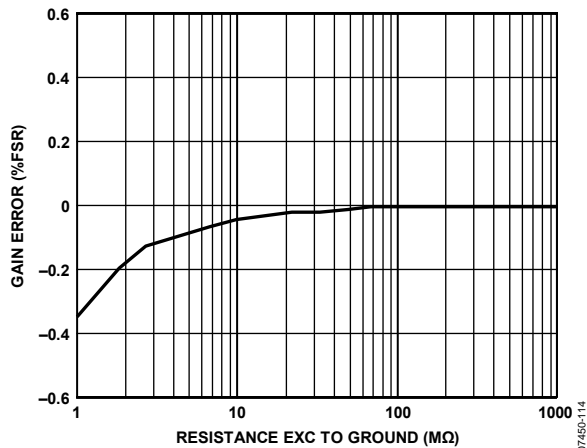

Figure 14. Capacitance Input Error vs. Parasitic Resistance EXC to GND, Single-Ended Mode,  $C_{IN(+)} \text{ to EXC} = 9 \text{ pF}$ ,  $V_{DD} = 3.3 \text{ V}$

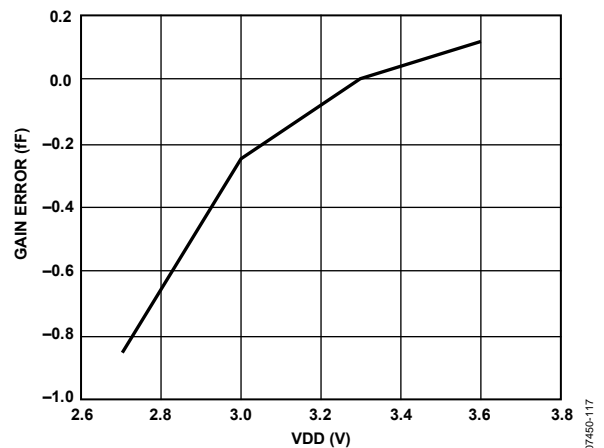

Figure 17. Capacitance Input Power Supply Rejection (PSR), Differential Mode;  $C_{IN(+)} \text{ to EXC} = 1.9 \text{ pF}$

# AD7152/AD7153

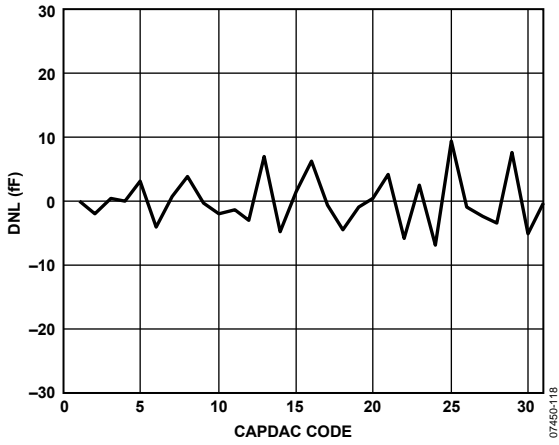

Figure 18. CAPDAC(+) Differential Nonlinearity (DNL)

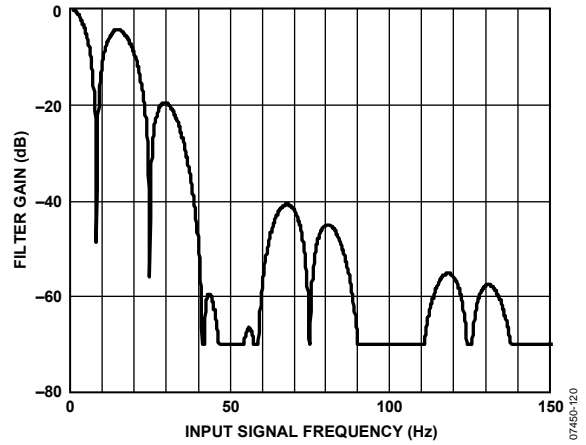

Figure 20. Capacitance Channel Frequency Response, Conversion Time = 60 ms

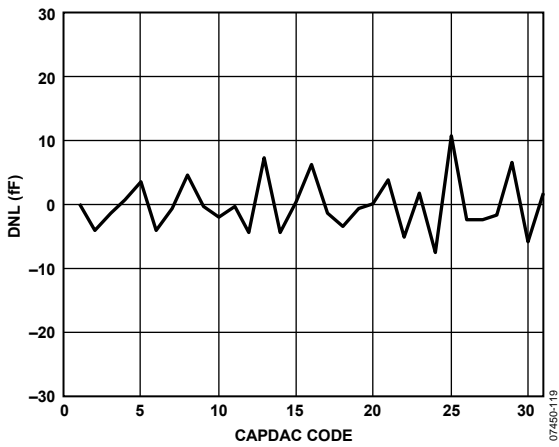

Figure 19. CAPDAC(-) Differential Nonlinearity (DNL)

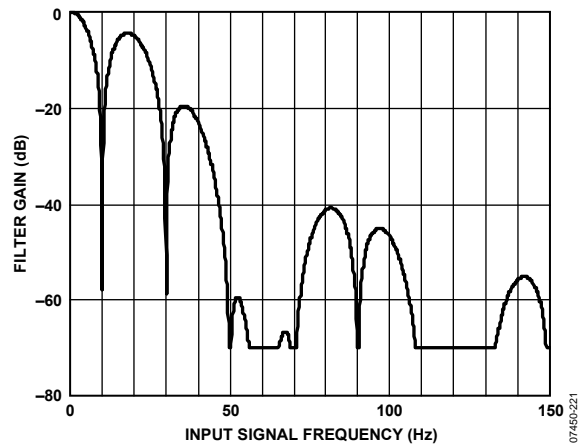

Figure 21. Capacitance Channel Frequency Response, Conversion Time = 50 ms

## SERIAL INTERFACE

The AD7152/AD7153 support an I<sup>2</sup>C-compatible, 2-wire serial interface. The two wires on the I<sup>2</sup>C bus are called SCL (clock) and SDA (data). These two wires carry all addressing, control, and data information one bit at a time over the bus to all connected peripheral devices. The SDA wire carries the data, while the SCL wire synchronizes the sender and receiver during the data transfer. I<sup>2</sup>C devices are classified as either master or slave devices. A device that initiates a data transfer message is called a master; a device that responds to this message is called a slave.

To control the AD7152/AD7153 via the bus, the following protocol must be followed. The master initiates a data transfer by establishing a start condition, defined by a high-to-low transition on SDA while SCL remains high. This indicates that the start byte follows. This 8-bit start byte is made up of a 7-bit address plus an R/W bit indicator.

All peripherals connected to the bus respond to the start condition and shift in the next 8 bits (7-bit address and an R/W bit). The bits arrive MSB first. The peripheral that recognizes the transmitted address responds by pulling the data line low during the ninth clock pulse. This is known as the acknowledge bit. All other devices withdraw from the bus at this point and maintain an idle condition. An exception to this is the general call address, which is described in the General Call section. The idle condition is where the device monitors the SDA and SCL lines waiting for the start condition and the correct address byte. The R/W bit determines the direction of the data transfer. A Logic 0 LSB in the start byte means that the master writes information to the addressed peripheral. In this case, the device becomes a slave receiver. A Logic 1 LSB in the start byte means that the master reads information from the addressed peripheral. In this case, the device becomes a slave transmitter. In all instances, the AD7152/AD7153 act as a standard slave device on the I<sup>2</sup>C bus.

The start byte address is Address 0x90 for a write and Address 0x91 for a read.

### WRITE OPERATION

When a write is selected, the byte following the start byte is always the register address pointer (subaddress) byte, which points to one of the internal registers on the AD7152/AD7153. The address pointer byte is automatically loaded into the address pointer register and acknowledged by the AD7152/AD7153. After the address pointer byte acknowledge, a stop condition, a repeated start condition, or another data byte can follow from the master.

A stop condition is defined by a low-to-high transition on SDA while SCL remains high. If a stop condition is ever encountered by the AD7152/AD7153, it returns to its idle condition and the address pointer is reset to Address 0x00.

If a data byte is transmitted after the register address pointer byte, the AD7152/AD7153 load this byte into the register that is currently addressed by the address pointer register. The parts send an acknowledge and the address pointer autoincrementer automatically increments the address pointer register to the next internal register address. Thus, subsequent transmitted data bytes are loaded into sequentially incremented addresses.

If a repeated start condition is encountered after the address pointer byte, all peripherals connected to the bus respond exactly as previously outlined for a start condition, that is, a repeated start condition is treated the same as a start condition. When a master device issues a stop condition, it relinquishes control of the bus, allowing another master device to take control. Hence, a master wanting to retain control of the bus issues successive start conditions known as repeated start conditions.

### READ OPERATION

When a read is selected in the start byte, the register that is currently addressed by the address pointer is transmitted onto the SDA line by the AD7152/AD7153. The regulator is then clocked out by the master device, and the AD7152/AD7153 await an acknowledge from the master.

If an acknowledge is received from the master, the address autoincrementer automatically increments the address pointer register and outputs the next addressed register content onto the SDA line for transmission to the master. If no acknowledge is received, the AD7152/AD7153 return to the idle state and the address pointer is not incremented.

The autoincrementer of the address pointers allows block data to be written or read from the starting address and subsequent incremental addresses.

In continuous conversion mode, autoincrementer of the address pointers should be used for reading a conversion result; that is, the three data bytes should be read using one multibyte read transaction rather than three separate single-byte transactions. The single-byte data read transaction may result in the data bytes from two different results being mixed.

# AD7152/AD7153

The user can also access any unique register (address) on a one-to-one basis without having to update all the registers. However, the address pointer register contents cannot be read.

If an incorrect address pointer location is accessed, or if the user allows the autoincrementer to exceed the required register address, apply the following requirements:

- In read mode, the AD7152/AD7153 continue to output various internal register contents until the master device issues a no acknowledge, start, or stop condition. The contents of the address pointers autoincrementer are reset to point to the status register at Address 0x00 when a stop condition is received at the end of a read operation. This allows the status register to be read (polled) continually without having to constantly write to the address pointer.
- In write mode, the data for the invalid address is not loaded into the registers of the AD7152/AD7153, but an acknowledge is issued by the AD7152/AD7153.

## AD7152/AD7153 RESET

To reset the AD7152/AD7153 without having to reset the entire I<sup>2</sup>C bus, an explicit reset command is provided. This command uses a particular address pointer word as a command word to reset the part and upload all default settings. The AD7152/AD7153 do not respond to the I<sup>2</sup>C bus commands (no acknowledge) during the default values upload for approximately 150 μs (maximum 200 μs).

The reset command address word is 0xBF.

## GENERAL CALL

When a master issues a slave address consisting of seven 0s with the eighth bit (R/W bit) set to 0, this is called the general call address. The general call address is for addressing every device connected to the I<sup>2</sup>C bus. The AD7152/AD7153 acknowledge this address and read the following data byte.

If the second byte is 0x06, the AD7152/AD7153 are reset, completely uploading all default values. The AD7152/AD7153 do not respond to the I<sup>2</sup>C bus commands (no acknowledge) during the default values upload for approximately 150 μs (maximum 200 μs).

The AD7152/AD7153 do not acknowledge any other general call commands.

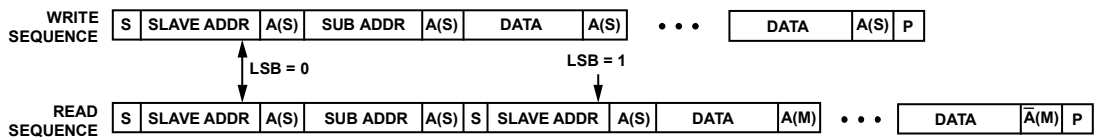
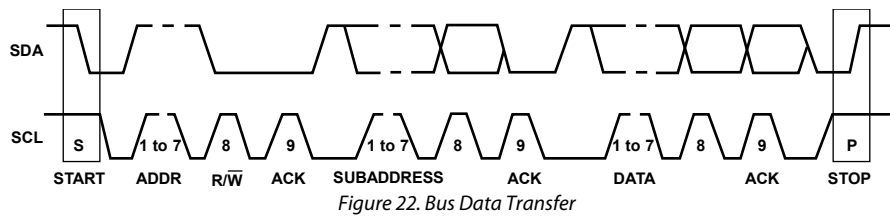

Table 5. I<sup>2</sup>C Abbreviation

Abbreviation	Definition
S	Start bit
P	Stop bit
A(S)	Acknowledge by slave
A(M)	Acknowledge by master
$\bar{A}(S)$	No acknowledge by slave
$\bar{A}(M)$	No acknowledge by master
ACK	Acknowledge
$\overline{R/W}$	Read/write

## REGISTER MAP

The master can write to or read from all of the registers except the address pointer register, which is a write-only register. The address pointer register determines which register the next read or write operation accesses. All communications with the part through the bus start with an access to the address pointer register. After the part has been accessed over the bus and a

read/write operation is selected, the address pointer register is set up. The address pointer register determines from or to which register the operation takes place. A read/write operation is performed from/to the target address, which then increments to the next address until a stop command on the bus is performed.

**Table 6. Register Summary**

Register Name	Subaddress		Access	Bit 7	Bit 6	Bit 5	Bit 4	Bit 3	Bit 2	Bit 1	Bit 0	Default Value
	Dec	Hex										
Status	0	0x00	R	PWDN	Unused	Unused	Unused	Unused	C1C2	RDY2	RDY1	0x03
Channel 1 Data MSB	1	0x01	R	Channel 1 data, high byte								0x00
Channel 1 Data LSB	2	0x02	R	Channel 1 data, low byte								0x00
Channel 2 Data MSB <sup>1</sup>	3	0x03	R	Channel 2 data, high byte								0x00
Channel 2 Data LSB	4	0x04	R	Channel 2 data, low byte								0x00
Channel 1 Offset MSB	5	0x05	R/W	Channel 1 offset calibration coefficient, high byte								0x80
Channel 1 Offset LSB	6	0x06	R/W	Channel 1 offset calibration coefficient, low byte								0x00
Channel 2 Offset MSB <sup>1</sup>	7	0x07	R/W	Channel 2 offset calibration coefficient, high byte								0x80
Channel 2 Offset LSB <sup>1</sup>	8	0x08	R/W	Channel 2 offset calibration coefficient, low byte								0x00
Channel 1 Gain MSB	9	0x09	R/W	Channel 1 gain coefficient, high byte, factory calibrated								0xXX
Channel 1 Gain LSB	10	0x0A	R/W	Channel 1 gain coefficient, low byte, factory calibrated								0xXX
Channel 1 Setup	11	0x0B	R/W	Range 1	Range 0	CAPDIFF	Unused	Unused				0x00
Channel 2 Gain MSB <sup>1</sup>	12	0x0C	R/W	Channel 2 gain coefficient, high byte, factory calibrated								0xXX
Channel 2 Gain LSB <sup>1</sup>	13	0x0D	R/W	Channel 2 gain coefficient, low byte, factory calibrated								0xXX
Channel 2 Setup <sup>1</sup>	14	0x0E	R/W	Range 1	Range 0	CAPDIFF	Unused	Unused				0x00
Configuration	15	0x0F	R/W	Unused	Unused	Unused	Ch1en	Ch2en	MD2	MD1	MD0	0x00
Reserved	16	0x10	R/W	Unused								0x00
CAPDAC POS	17	0x11	R/W	DACPen	Unused	Unused	DACP Bits[4:0] value					0x00
CAPDAC NEG	18	0x12	R/W	DACNen	Unused	Unused	DACN Bits[4:0] value					0x00
Configuration2	26	0x1A	R/W	Unused	Unused	OSR1	OSR0	Unused	Unused	Unused	Unused	0x00

<sup>1</sup> AD7152 only.

# AD7152/AD7153

## STATUS REGISTER

**Address 0x00**

**Read Only**

**Default Value 0x03**

This register indicates the status of the converter. The status register can be read via the 2-wire serial interface to query a finished conversion.

**Table 7. Status Register Bit Map**

Bit	Bit 7	Bit 6	Bit 5	Bit 4	Bit 3	Bit 2	Bit 1	Bit 0
Mnemonic	PWDN	Unused	Unused	Unused	Unused	C1C2	$\overline{\text{RDY2}}$	$\overline{\text{RDY1}}$
Default	0	0	0	0	0	0	1	1

**Table 8. Status Register Bit Descriptions**

Bit	Mnemonic	Description
7	PWDN	PWDN = 1 indicates that the $V_{DD}$ voltage level is below 2.45 V typically or part is in power-down mode
6 to 3	N/A	Not used, always read 0
2	C1C2	C1C2 = 0 indicates that the last conversion performed was from Channel 1, C1C2 = 1 indicates that the last conversion performed was from Channel 2
1	$\overline{\text{RDY2}}$	$\overline{\text{RDY2}}$ = 0 indicates that a conversion on the Channel 2 has been finished and new unread data is available (AD7152 only)
0	$\overline{\text{RDY1}}$	$\overline{\text{RDY1}}$ = 0 indicates that a conversion on the Channel 1 has been finished and new unread data is available

## DATA REGISTERS

**Address 0x01, Address 0x02 for Channel 1**  
**Address 0x03, Address 0x04 (AD7152 Only) Channel 2**  
**16 Bits, Read-Only, Default Value 0x0000**

Data from the last complete capacitance-to-digital conversion reflects the capacitance on the input. Only the 12 MSBs of the data registers are used for the CDC result. The 4 LSBs are always 0, as shown in Figure 24.

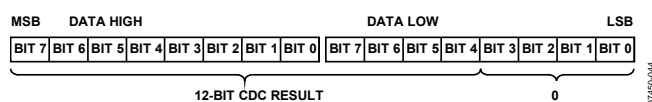

Figure 24. CDC Data Register

The AD7152/AD7153 are factory gain calibrated and map the CDC full-scale raw data range of 0x3000 to 0xCFF0F to a CDC full-scale data register range of 0x0000 to 0xFFFF0 (see Table 9).

**Table 9. AD7152/AD7153 Capacitance-to-Data Mapping**

Data Reg	Input Capacitance (4 pF range)	
	Differential Mode	Single-Ended Mode
0x0000	Negative full scale (–2 pF)	Zero scale (0 pF)
0x8000	Zero scale (0 pF)	Midscale (2 pF)
0xFFFF0	Positive full scale (+2 pF)	Full scale (4 pF)

The data register output in differential mode is internally calculated using the following equation:

$$\text{Data Reg} = (\text{Code} - (\text{Offset Reg} - 0x8000)) \times \text{Gain} + 0x8000 \quad (1)$$

The input capacitance can be calculated from the output data using the following equation:

$$C(\text{pF}) = \frac{\text{Data Reg} - 0x8000}{0xFFFF0} \times \text{Input Range} \quad (2)$$

The data register output in single-ended mode is internally calculated using the following equation:

$$\text{Data Reg} = (\text{Code} - (\text{Offset Reg} - 0x3000)) \times \text{Gain} \quad (3)$$

The input capacitance can be calculated from the output data using the following equation:

$$C(\text{pF}) = \frac{\text{Data Reg}}{0xFFFF0} \times \text{Input Range} \quad (4)$$

where *Input Range* = 4 pF, 2 pF, 1 pF, or 0.5 pF.

A data register is updated after a finished conversion on the capacitive channel, with one exception: when the serial interface read operation from the data register is in progress, the data register is not updated and the new capacitance conversion result is lost.

The stop condition on the serial interface is considered to be the end of the read operation.

Therefore, to prevent incorrect data reading through the serial interface, the two bytes of a data register should be read sequentially using the register address pointer auto-increment feature of the serial interface.

## OFFSET CALIBRATION REGISTERS

**Address 0x05, Address 0x06 for Channel 1,**  
**Address 0x07, Address 0x08 for Channel 2 (AD7152 Only)**  
**16 Bits Read/Write, Default Value 0x8000**

The offset calibration registers hold the zero-scale calibration coefficients.

The zero-scale calibration coefficient digitally maps the zero capacitance on the CDC input to the zero-scale data code. The coefficient can be used for compensation of the AD7152/AD7153 internal offset as well as the system level offset within specified offset calibration limits.

Users can set the coefficient by executing the offset calibration after connecting the zero-scale capacitance to the system input. Alternatively, the coefficient value can be written to the offset calibration register(s) by the host software, for example, values stored in a host nonvolatile memory.

Note that there is a difference between code mapping in differential and single-ended input mode. In differential mode, the nominal zero-scale calibration coefficient value is a power-on default, 0x8000. In single-ended mode, the nominal zero-scale calibration coefficient value is 0x3000.

The difference means that before using the single-ended mode (or any time when changing between modes afterwards), the user should either perform offset calibration with capacitance close to 0 pF connected to the input or write the offset calibration register(s) value(s) close to 0x8000 for differential mode or value close to 0x3000 for single-ended mode.

On the AD7152, the two capacitive channels have individual offset registers and each channel can be calibrated individually.

## GAIN CALIBRATION REGISTERS

**Address 0x09, Address 0x0A for Channel 1**  
**Address 0x0C, Address 0x0D for Channel 2 (AD7152 only)**  
**16 Bits Read/Write, Default Value 0xXXXX**

The capacitive gain calibration registers hold the capacitive channel full-scale factory calibration coefficient. The gain calibration factor can be calculated using the following equation:

$$\text{Gain} = \frac{2^{16} + \text{Gain Reg}}{2^{16}} \quad (5)$$

On the AD7152, the two capacitive channels each have a gain register, which allows the part to gain calibrate each channel individually.

# AD7152/AD7153

## CAP SETUP REGISTERS

**Address 0x0B for Channel 1**

**Address 0x0E Channel 2 (AD7152 Only)**

**Default Value 0x00**

**Table 10. CAP Setup Register Bit Map**

Bit	Bit 7	Bit 6	Bit 5	Bit 4	Bit 3	Bit 2	Bit 1	Bit 0
Mnemonic	Range 1	Range 0	CAPDIFF	Unused	Unused	Unused	Unused	Unused
Default	0	0	0	0	0	0	0	0

**Table 11. CAP Setup Register Bit Descriptions**

Bit	Mnemonic	Description			
7	Range 1	Capacitive input range and mode setup			
6	Range 0				
5	CAPDIFF	<b>Capacitive Input Range</b>			
		<b>Range 1</b>	<b>Range 0</b>	<b>CAPDIFF = 1 (Differential Mode)</b>	<b>CAPDIFF = 0 (Single-Ended Mode)</b>
		0	0	±1 pF	2 pF
		0	1	±0.25 pF	0.5 pF
		1	0	±0.5 pF	0.25 pF
1	1	±2 pF	4 pF		
4 to 0	N/A	These bits must be 0 for proper operation			

## CONFIGURATION REGISTER

**Address Pointer 0x0F**

**Default Value 0x00**

**Table 12. Configuration Register Bit Map**

Bit	Bit 7	Bit 6	Bit 5	Bit 4	Bit 3	Bit 2	Bit 1	Bit 0
Mnemonic	Unused	Unused	Unused	Ch1en	Ch2en	MD2	MD1	MD0
Default	0	0	0	0	0	0	0	0

**Table 13. Configuration Register Bit Descriptions**

Bit	Mnemonic	Description			
7 to 5	N/A	These bits must be 0 for proper operation			
4	Ch1en	Ch2en = 1 enables Channel 1 for single conversion, continuous conversion, or calibration			
3	Ch2en	Ch2en = 1 enables Channel 2 for single conversion, continuous conversion, or calibration			
2	MD2	Converter mode of operation setup			
1	MD1				
0	MD0	<b>MD2</b>	<b>MD1</b>	<b>MD0</b>	<b>Mode</b>
		0	0	0	Idle
		0	0	1	Continuous conversion
		0	1	0	Single conversion
		0	1	1	Power-down
		1	0	0	N/A
		1	0	1	Capacitance system offset calibration
1	1	0	Capacitance system gain calibration		
1	1	1	N/A		



**CAPDAC POS REGISTER****Address 0x11****Default Value 0x00****Table 14. Status Register Bit Map**

Bit	Bit 7	Bit 6	Bit 5	Bit 4	Bit 3	Bit 2	Bit 1	Bit 0
Mnemonic	DACPen	Unused	Unused	DACP – Bits[4:0] Value				
Default	0	0	0	0x00				

**Table 15. Status Register Bit Descriptions**

Bit	Mnemonic	Description
7	DACPen	DACPen = 1 connects the capacitive DAC POS to the positive capacitive input
6 to 5	N/A	These bits must be 0 for proper operation
4 to 0	DACP	DACP value, Code 0x00 = 0 pF, Code 0x1F = full range

**CAPDAC NEG REGISTER****Address 0x12****Default Value 0x00****Table 16. Status Register Bit Map**

Bit	Bit 7	Bit 6	Bit 5	Bit 4	Bit 3	Bit 2	Bit 1	Bit 0
Mnemonic	DACNen	Unused	Unused	DACN – Bit[4:0] Value				
Default	0	0	0	0x00				

**Table 17. Status Register Bit Descriptions**

Bit	Mnemonic	Description
7	DACNen	DACNen = 1 connects the capacitive DAC NEG to the positive capacitive input
6 to 5	N/A	These bits must be 0 for proper operation
4 to 0	DACN	DACN value, Code 0x00 = 0 pF, Code 0x1F = full range

**CONFIGURATION2 REGISTER****Address 0x1A,****Default Value 0x00****Table 18. Configuration2 Register Bit Map**

Bit	Bit 7	Bit 6	Bit 5	Bit 4	Bit 3	Bit 2	Bit 1	Bit 0
Mnemonic	Unused	Unused	OSR1	OSR0				
Default	0	0	0	0	0	0	0	0

**Table 19. Configuration2 Register Bit Descriptions**

Bit	Mnemonic	Description				
7 to 6	N/A	These bits must be 0 for proper operation				
5	OSR1	Capacitive channel digital filter setup; conversion time/update rate setup per channel				
4	OSR0					
			<b>OSR1</b>	<b>OSR0</b>	<b>Conversion Time (ms)</b>	<b>Update Rate (Hz)</b>
			0	0	5	200
			0	1	20	50
		1	0	50	20	
		1	1	60	16.7	
3 to 0	N/A	These bits must be 0 for proper operation				

# AD7152/AD7153

## CIRCUIT DESCRIPTION

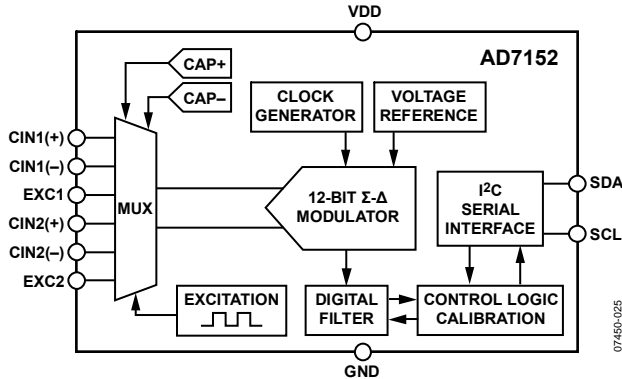

Figure 25. AD7152 Block Diagram

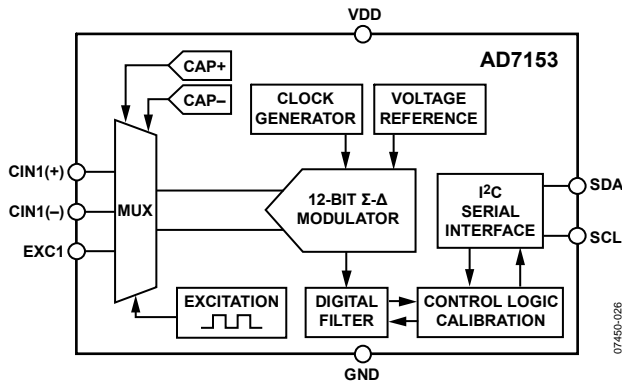

Figure 26. AD7153 Block Diagram

The core of the AD7152/AD7153 is a precision converter consisting of a second-order modulator ( $\Sigma$ - $\Delta$  or charge-balancing) and a third-order digital filter.

In addition to the converter, the AD7152/AD7153 integrate a multiplexer, an excitation source, and CAPDACs for the capacitive inputs, a voltage reference, a complete clock generator, a control and calibration logic, and an I<sup>2</sup>C-compatible serial interface.

The AD7153 has one capacitive input, while the AD7152 has two capacitive inputs. For the AD7152, the modulator input and the excitation source are multiplexed between the converting channel. All other features and specifications are identical for both parts.

## CAPACITANCE-TO-DIGITAL CONVERTER (CDC)

Figure 27 shows the CDC simplified functional diagram. The measured capacitance  $C_x$  is connected between the excitation source and the  $\Sigma$ - $\Delta$  modulator input. A square-wave excitation signal is applied on the  $C_x$  during the conversion and the modulator continuously samples the charge going through the  $C_x$ . The digital filter processes the modulator output, which is a stream of 0s and 1s containing the information in 0 and 1 density. The data from the digital filter is scaled, applying the calibration coefficients, and the final result can be read through the serial interface. The AD7152/AD7153 are designed for floating capacitive sensors. Therefore, both  $C_x$  plates have to be isolated from ground.

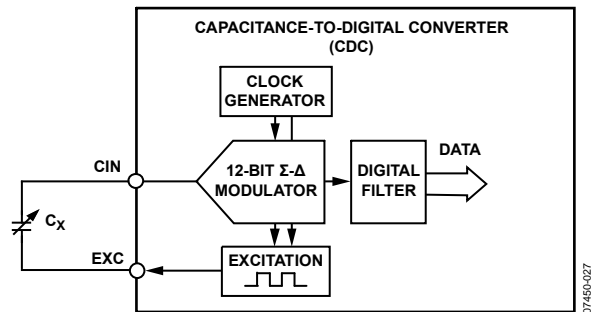

Figure 27. CDC Simplified Block Diagram

## EXCITATION SOURCE

The AD7152/AD7153 have one excitation source. For the AD7152, the excitation source is switched between the excitation pins, EXC1 and EXC2, depending on which channel performs a conversion.

## CAPDAC

The CDC full-scale input range of the AD7152/AD7153 can be set to  $\pm 0.25$  pF,  $\pm 0.5$  pF,  $\pm 1$  pF, and  $\pm 2$  pF in differential mode or 0.5 pF, 1 pF, 2 pF, and 4 pF in single-ended mode. For simplicity, the following text and figures use the maximum full scale of  $\pm 2$  pF and +4 pF.

The parts can accept a higher capacitance on the input and the common-mode or offset capacitance (unchanging component) can be balanced by programmable on-chip CAPDACs.

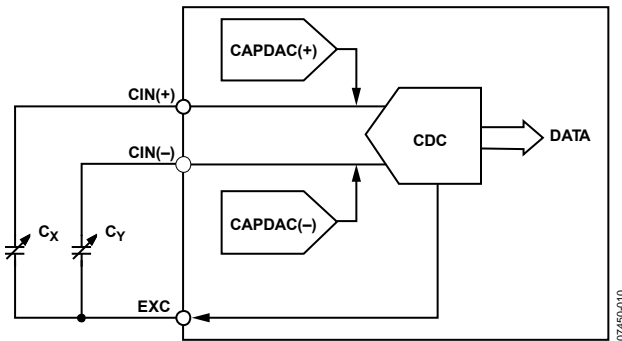

Figure 28. Using a CAPDAC

The CAPDAC can be understood as a negative capacitance connected internally to the CIN pin. There are two independent CAPDACs, one connected to the CIN(+) and the second connected to the CIN(-).

In differential mode, the relationship between the capacitance input and output data can be expressed as

$$DATA \approx (C_X - CAPDAC(+)) - (C_Y - CAPDAC(-))$$

In single-ended mode, the relationship between the capacitance input and output data can be expressed as

$$DATA \approx C_X - (CAPDAC(+) + CAPDAC(-))$$

The CAPDACs have a 5-bit resolution each, monotonic transfer function, are well matched to each other, and have a defined temperature coefficient. The CAPDAC full range (absolute value) is not factory calibrated and can vary up to  $\pm 20\%$  with the manufacturing process (see the Specifications section, Figure 18, and Figure 19).

The CAPDACs are shared by the two capacitive channels on the AD7152. If the CAPDACs need to be set individually, the host controller software should reload the CAPDAC values to the AD7152 before executing a conversion on a different channel.

## SINGLE-ENDED CAPACITIVE INPUT

When configured for a single-ended mode (the CAPDIFF bit in the Channel 1 Setup or Channel 2 Setup registers is set to 0), the AD7152/AD7153 CIN(-) pin is disconnected internally. The CDC (without using the CAPDACs) can measure positive input capacitance in the range of 0 pF to 4 pF (see Figure 29).

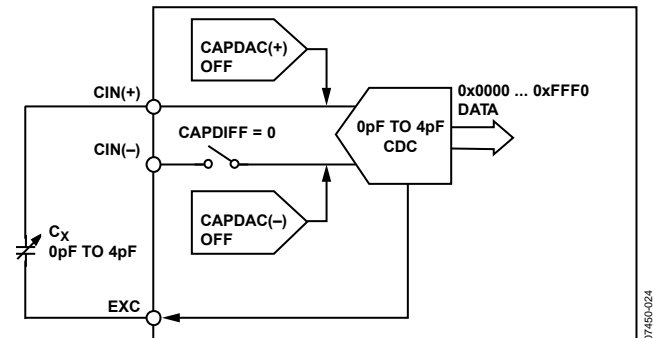

Figure 29. CDC Single-Ended Input Mode

The CAPDAC can be used for programmable shifting of the input range.

Figure 30 shows how to shift the input range up to 9 pF absolute value of capacitance connected to the CIN(+) using the CAPDAC(+) only.

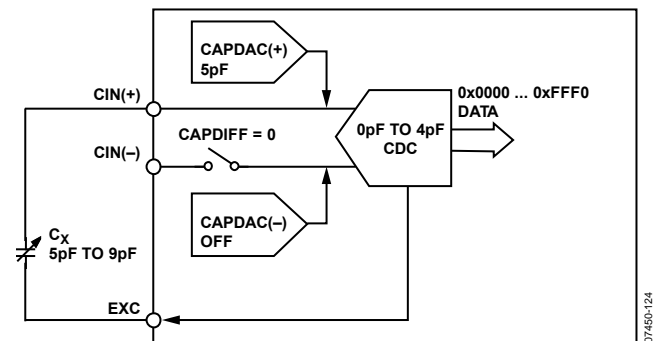

Figure 30. Using CAPDAC in Single-Ended Mode

Figure 31 shows how to shift the input range up to 14 pF absolute value of capacitance connected to the CIN(+) using both CAPDAC(+) and CAPDAC(-).

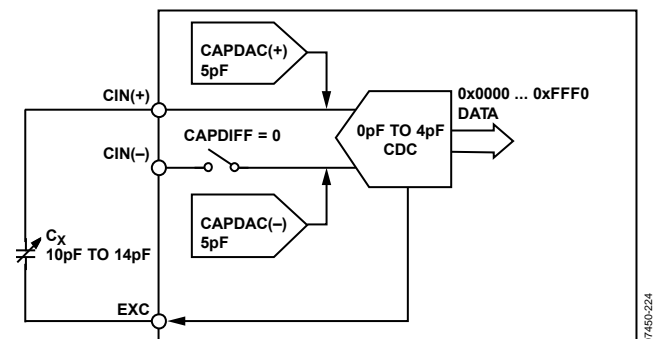

Figure 31. Using CAPDAC in Single-Ended Mode

# AD7152/AD7153

## DIFFERENTIAL CAPACITIVE INPUT

When configured for differential mode (the CAPDIFF bit in the Channel 1 Setup or Channel 2 Setup registers is set to 1), the CDC measures the difference between positive and negative capacitance input.

Each of the two input capacitances,  $C_X$  and  $C_Y$ , between the EXC and CIN pins must be less than 2 pF (without using the CAPDACs) or must be less than 9 pF and balanced by the CAPDACs. Balancing by the CAPDACs means that both  $C_X - \text{CAPDAC}(+)$  and  $C_Y - \text{CAPDAC}(-)$  are less than 2 pF.

If the unbalanced capacitance between the EXC and CIN pins is higher than 2 pF, the CDC introduces a gain error, an offset error, and nonlinearity error (see Figure 32, Figure 33, and Figure 34).

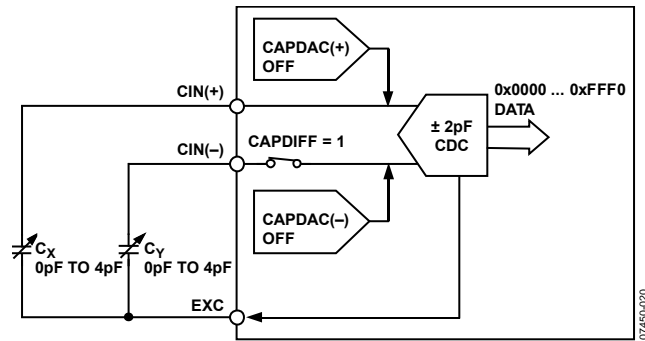

Figure 32. CDC Differential Input Mode

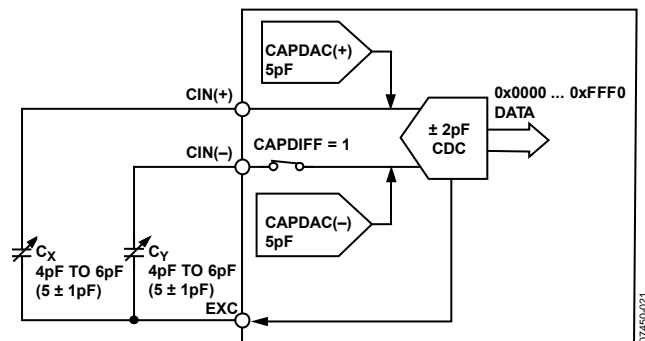

Figure 33. Using CAPDAC in Differential Mode

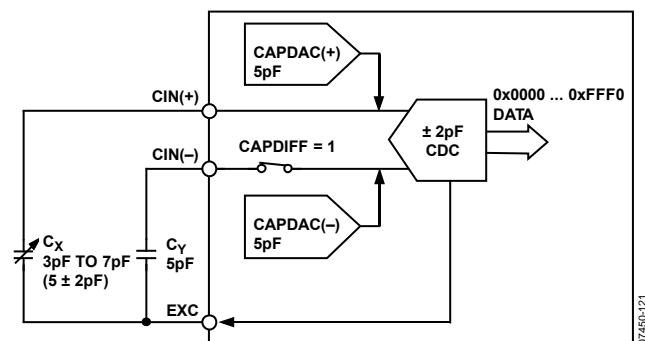

Figure 34. Using CAPDAC in Differential Mode

## PARASITIC CAPACITANCE TO GROUND

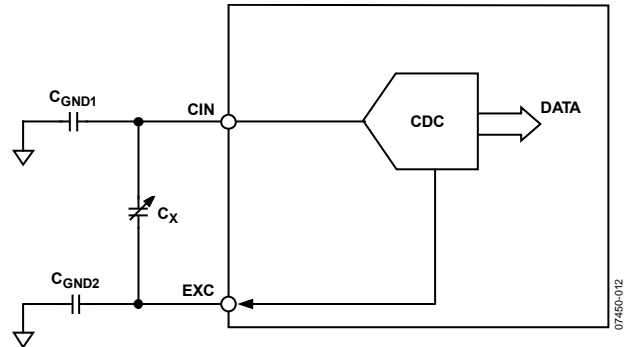

Figure 35. Parasitic Capacitance to Ground

The CDC architecture used in the AD7152/AD7153 measures  $C_X$  connected between the EXC pin and the CIN pin. In theory, any capacitance,  $C_{GND}$ , to ground should not affect the CDC result (see Figure 35).

The practical implementation of the circuitry in the chip implies certain limits and the result is gradually affected by capacitance to ground. See the allowed capacitance to GND in the Specifications table and, Figure 9 through Figure 12.

## PARASITIC RESISTANCE TO GROUND

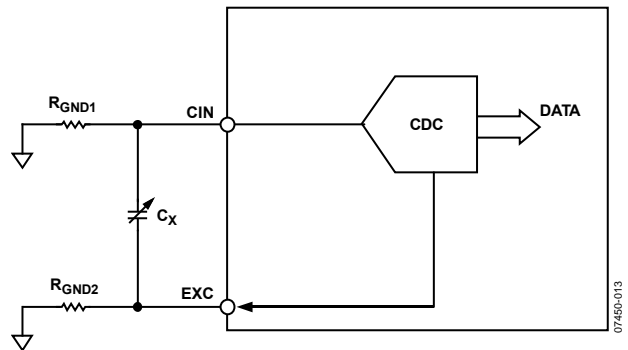

Figure 36. Parasitic Resistance to Ground

The CDC result can be affected by a leakage current from the  $C_X$  to ground; therefore, the  $C_X$  should be isolated from the ground. The influence of the leakage current varies with the power supply voltage (see Figure 36).

A higher leakage current to ground results in a gain error, an offset error, and a nonlinearity error (see Figure 13 and Figure 14).

## PARASITIC PARALLEL RESISTANCE

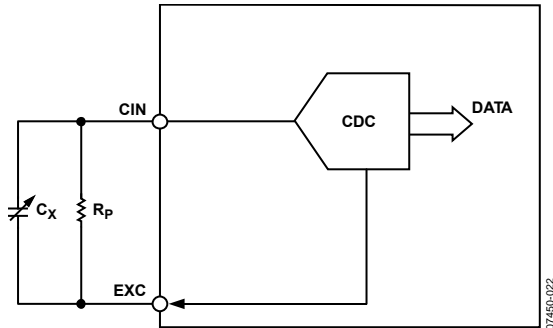

Figure 37. Parasitic Parallel Resistance

The CDC measures the charge transfer between the EXC pin and CIN pin. Any resistance connected in parallel to the measured capacitance  $C_x$  (see Figure 37), such as the parasitic resistance of the sensor, also transfers charge. Therefore, the parallel resistor is seen as an additional capacitance in the output data causing a capacitive input error (see Figure 15).

## PARASITIC SERIAL RESISTANCE

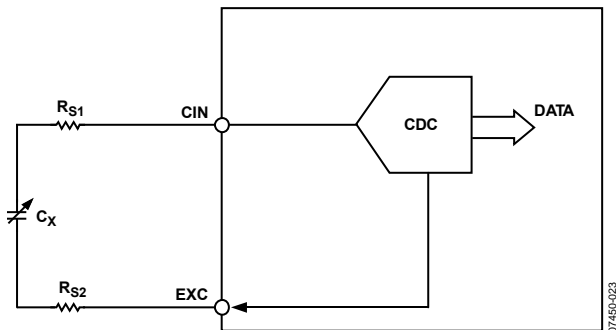

Figure 38. Parasitic Serial Resistance

The CDC result is affected by a resistance in series with the measured capacitance. The total serial resistance, which refers to  $R_{s1}$  and  $R_{s2}$  in Figure 38, should be less than 20 k $\Omega$  for the specified performance (see Figure 16).

## INPUT EMC PROTECTION

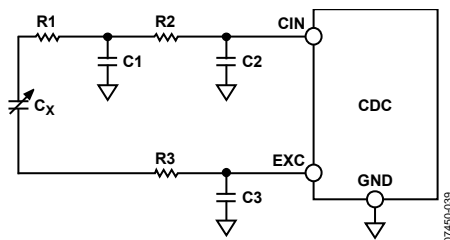

Figure 39. AD7152/AD7153 EMC Protection

Some applications may require an additional input filter for improving electromagnetic compatibility (EMC). Any input filter must be carefully designed, considering the balance between the system capacitance performance and system electromagnetic immunity.

Figure 39 shows one of the possible input circuit configurations significantly improving the system immunity against high frequency noise and slightly affecting the AD7152 performance in terms of additional gain and offset error.

## POWER SUPPLY DECOUPLING AND FILTERING

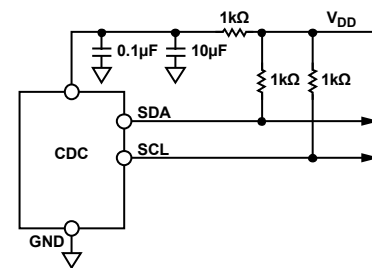

Figure 40. AD7152/AD7153  $V_{DD}$  Decoupling and Filtering

The AD7152 has good dc and low frequency power supply rejection but may be sensitive to higher frequency ripple and noise, specifically around the excitation frequency and its harmonics. Figure 40 shows a possible circuit configuration for improving the system immunity against ripple and noise coupled to the AD7152 via the power supply.

Because the serial interface is connected to the other circuits in the system, it is better to connect the pull-up resistors on the other side of the  $V_{DD}$  filter than to connect to the AD7152.

## CAPACITIVE GAIN CALIBRATION

The gain of the AD7152/AD7153 is factory calibrated for the full scale of 4 pF in the production for each part individually. The factory gain coefficient is stored in a one-time programmable (OTP) memory and is copied to the capacitive gain registers at power-up or after reset.

The gain can be changed by executing a capacitance gain calibration mode, for which an external full-scale capacitance needs to be connected to the capacitance input, or by writing a user value to the capacitive gain register. This change is temporary and the factory gain coefficient can be reloaded after power-up or reset. The part is tested and specified only for use with the default factory calibration coefficient.

## CAPACITIVE SYSTEM OFFSET CALIBRATION

The capacitive offset is dominated by the parasitic offset in the application, such as the initial capacitance of the sensor, any parasitic capacitance of tracks on the board, and the capacitance of any other connections between the sensor and the CDC. Therefore, the AD7152/AD7153 are not factory calibrated for capacitive offset. The user should calibrate the system capacitance offset in the application.

## AD7152/AD7153

The offset register of the AD7152/AD7153 allows for offset calibration over the full capacitive input range. However, the user must ensure that the offset to be removed is within 40% of the full scale range; this can be achieved by using the CAPCAC to perform a coarse offset calibration and use the system offset calibration then to compensate for an offset within the 40% of full-scale range pF of the CAPDAC.

The offset calibration register is reloaded by the default value 0x8000 at power-on or after reset. Therefore, if the offset calibration is not repeated after each system power-up, the

calibration coefficient value should be stored by the host controller and reloaded as part of the AD7152/AD7153 setup.

Note that the AD7152/AD7153 zero scale for differential mode is around 0x8000; therefore, the offset register also needs a value of around 0x8000, where the zero scale in single-ended mode is 0x0000, with a required offset register value of 0x3000. For more detailed information, see the Data Registers section.

### TYPICAL APPLICATION DIAGRAM

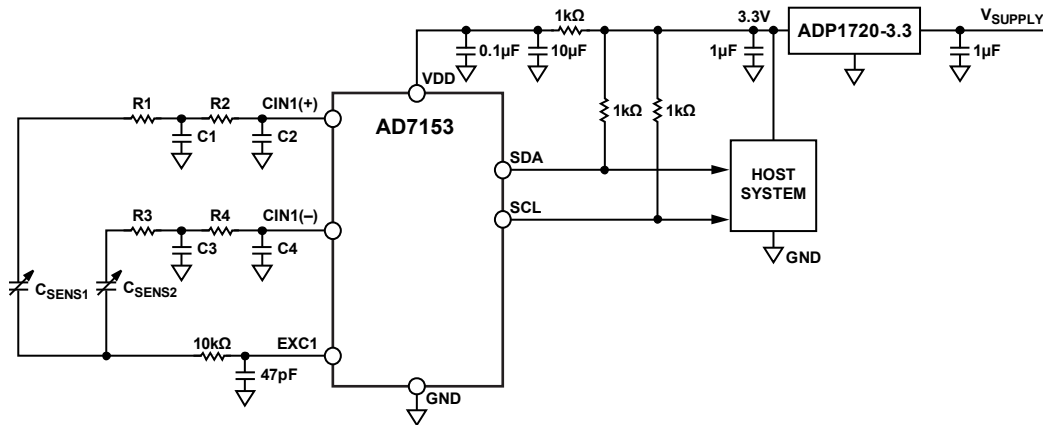
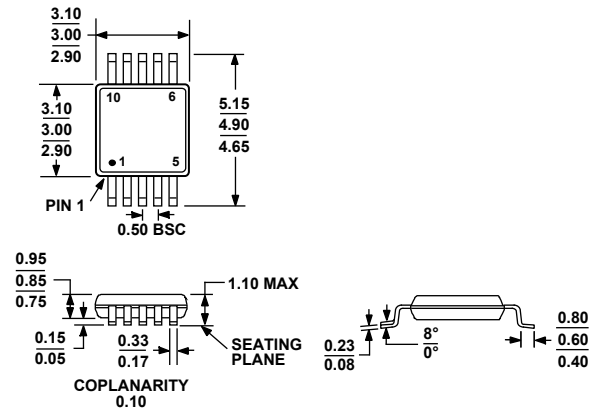

Figure 41. Basic Application Diagram for a Differential Capacitive Sensor

07450-081

## OUTLINE DIMENSIONS



COMPLIANT TO JEDEC STANDARDS MO-187-BA

Figure 42. 10-Lead Mini Small Outline Package [MSOP]  
(RM-10)

Dimensions shown in millimeters

## ORDERING GUIDE

Model	Temperature Range	Package Description	Package Option	Branding
AD7152BRMZ <sup>1</sup>	-40°C to +85°C	10-Lead Mini Small Outline Package [MSOP]	RM-10	C5P
AD7152BRMZ-REEL <sup>1</sup>	-40°C to +85°C	10-Lead Mini Small Outline Package [MSOP]	RM-10	C5P
AD7153BRMZ <sup>1</sup>	-40°C to +85°C	10-Lead Mini Small Outline Package [MSOP]	RM-10	C5Q
AD7153BRMZ-REEL <sup>1</sup>	-40°C to +85°C	10-Lead Mini Small Outline Package [MSOP]	RM-10	C5Q
EVAL-AD7152EBZ <sup>1</sup>		Evaluation Board		

<sup>1</sup> Z = RoHS Compliant Part.

**AD7152/AD7153**

## **NOTES**

Purchase of licensed I<sup>2</sup>C components of Analog Devices or one of its sublicensed Associated Companies conveys a license for the purchaser under the Philips I<sup>2</sup>C Patent Rights to use these components in an I<sup>2</sup>C system, provided that the system conforms to the I<sup>2</sup>C Standard Specification as defined by Philips.