



# Evaluation Board for the AD9835 Direct Digital Synthesizer

## EVAL-AD9835EB

### FEATURES

Full-Featured Evaluation Board for the AD9835  
Various Linking Options  
PC Software for Control of AD9835  
On-Board Patchwork Area

### INTRODUCTION

This Application Note describes the evaluation board for the AD9835 Direct Digital Synthesizer (DDS). The AD9835 is a numerically controlled oscillator employing a phase accumulator, a sine look-up table and a 10-bit D/A converter. The part can be operated with clock frequencies up to 50 MHz. Both phase modulation and frequency modulation can be performed with the AD9835. Full data on the AD9835 is available in the AD9835 datasheet available from Analog Devices and should be consulted in conjunction with this Application Note when using the evaluation board.

The evaluation board interfaces to the parallel port of an IBM compatible PC. Software is available with the evaluation board which allows the user to easily program the AD9835.

Components on the AD9835 Evaluation Board include a 50 MHz oscillator which provides the MCLK for the AD9835. The user can remove this oscillator, if required, and drive the AD9835 with a different clock oscillator or an external clock source via a BNC connector. A digital buffer is also on the board so that the signals from the edge connector are buffered.

### OPERATING THE AD9835 EVALUATION BOARD

#### Power Supplies

This evaluation board has two analog power supply inputs:  $AV_{DD}$  and  $AGND$ .  $AV_{DD}$  equals +5V or +3.3V and is used to provide the  $AV_{DD}$  for the AD9835.  $DGND$  and  $DV_{DD}$  connections are also available. The  $DV_{DD}$  is used to provide the  $DV_{DD}$  for the AD9835, the 50 MHz oscillator and the  $DV_{DD}$  for the digital buffer.  $DGND$  and  $AGND$  are connected under the AD9835. Therefore, it is recommended not to connect  $AGND$  and  $DGND$  elsewhere in the system.

All power supplies are decoupled to ground.  $AV_{DD}$  and  $DV_{DD}$  are decoupled using 10 $\mu$ F tantalum capacitors and 0.1 $\mu$ F ceramic capacitors at the input to the evaluation board. The power supplies are again decoupled using 0.1 $\mu$ F capacitors at the AD9835, the crystal and the logic.

Figure 1: Evaluation Board Setup

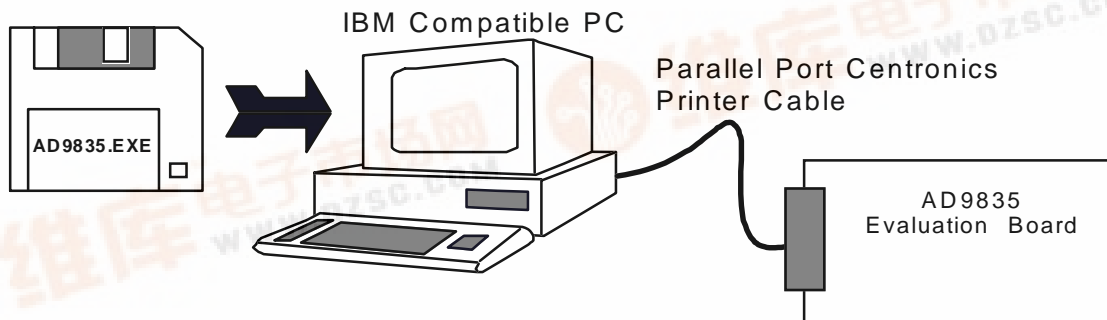

# EVAL-AD9835EB

## LINK AND SWITCH OPTIONS

There are four link options which must be set for the required operating setup before using the evaluation board. The functions of these link options are outlined below.

### Link No.      Function

LK1	When SELSRC = 0, the PSEL1 input can be controlled by the user via a SMB connector or alternatively, by switch SW1-2. With LK1 in position "A", PSEL1 can be controlled from an external logic source through the SMB connector, PSEL1. With LK1 in position "B" PSEL1 is connected to SW1, allowing the user to control the PSEL1 signal using the double throw switch, SW1-2.
LK2	When SELSRC = 0, the PSEL0 input can be controlled by the user via a SMB connector or alternatively, by switch SW1-1. With LK2 in position "A", PSEL0 can be controlled from an external logic source through the SMB connector, PSEL0. With LK2 in position "B" PSEL0 is connected to SW1, allowing the user to control the PSEL0 signal using the double throw switch, SW1-1.
LK3	When SELSRC = 0, the FSELECT input can be controlled by the user via a SMB connector or alternatively, by switch SW1-3. With LK3 in position "A", FSELECT can be controlled from an external logic source through the SMB connector, FSEL1. With LK3 in position "B" FSELECT is connected to SW1, allowing the user to control the FSELECT signal using the double throw switch, SW1-3.
LK4	The reference to the AD9835 can be provided by the on-board reference, which is available at REFOUT, or an external reference of nominal value 1.21 V can be used. When LK4 is closed, the on-board reference is used. When this link is opened, REFIN is disconnected from REFOUT and the reference must be provided by the user via the SMB connector, REFIN1.

## SET-UP CONDITIONS

Care should be taken before applying power and signals to the evaluation board to ensure that all link positions are as per the required operating mode. Table 1 shows the position in which all the links are set when the evaluation board is packaged.

**Table 1: Initial Link and Switch Positions**

Link No.	Position	Function
LK1	B	LK1 is arranged so that PSEL1 is tied to SW1-2.
LK2	B	LK2 is arranged so that PSEL0 is tied to SW1-1.
LK3	B	LK3 is arranged so that FSELECT is tied to SW1-3.
LK4	IN	REFOUT is tied to REFIN.
SW1	DV <sub>DD</sub>	All the SW1 switches are arranged so that DV <sub>DD</sub> is selected.

## EVALUATION BOARD INTERFACING

Interfacing to the evaluation board is via a 36-way centronics female connector, J1. The pinout for the J1 connector is shown in Figure 2 and its pin designations are given in Table 2.

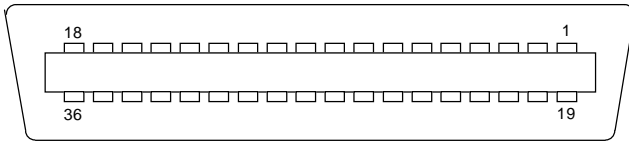

**Figure 2: Pin Configuration for 36-Way Connector, J1.**

### 36-Way Connector Pin Description

DGND	Digital Ground. These lines are connected to the digital ground plane on the evaluation board.
SDATA	Serial Data. Data applied to this pin is buffered before being applied to the AD9835. The serial data applied to the SDATA pin is written to the serial register of the device. The data is then transferred to the destination register, the control register or the FSELECT/PSEL registers, the control bits being used to identify the destination for the data information. The AD9835 accepts CMOS logic levels.
SCLK	Serial Clock. The signal on this pin is buffered before being applied to the SCLK pin of the AD9835. The AD9835 requires an external serial clock when data/control information is being written to the device. The serial clock can be continuous or, it can idle high or low between write operations.
FSYNC	The signal on this pin is buffered before being applied to the FSYNC pin of the AD9835. The FSYNC signal frames the 16-bit word being loaded into the AD9835, the signal going low for 16 SCLK cycles.

**Table 2. 36-Way Connector Pin Functions**

PIN NO.	MNEMONIC
2	SCLK
3	SDATA
4	FSYNC
19-30	DGND

Note: The remainder of the pins on the 36-way connector are no connects.

## SOCKETS

There are six sockets relevant to the operation of the AD9835 on this evaluation board. The function of these sockets is outlined in Table 3.

**Table 3. Socket Functions**

Socket	Function
REFIN	Sub-Miniature BNC Socket for REFIN.
IOUT	Sub-Miniature BNC Socket for IOUT.
MCLK	Sub-Miniature BNC Socket for the MCLK input.
FSEL	Sub-Miniature BNC Socket for FSELECT.
PSEL0	Sub-Miniature BNC Socket for PSEL0.
PSEL1	Sub-Miniature BNC Socket for PSEL1.

## CONNECTORS

There are three connectors on the AD9835 evaluation board as outlined in Table 4.

**Table 4. Connector Functions**

Connector	Functions
J1	36-Way Centronics Connector.
J2	PCB Mounting Terminal Block. The Digital Power Supply to the Evaluation Board is provided via this Connector.
J3	PCB Mounting Terminal Block. The Analog Power Supply to the Evaluation Board is provided via this Connector.

## SWITCHES

There is one switch on the AD9835 evaluation board. This switch is a double throw, end stackable switch. This switch can be used to control the FSELECT, PSEL0 and PSEL1 inputs.

# EVAL-AD9835EB

## SOFTWARE DESCRIPTION

The AD9835 evaluation board comes with a floppy disk containing software that allows the user to control the AD9835 from an IBM compatible PC. The PC is connected to the evaluation board by a standard Centronics™ printer cable.

Installing the Software:

The software will run on any IBM compatible PC which meets the following requirements.

- Microsoft Windows 3.1 or Windows95 installed.
- 80386 or higher processor.
- At least 1.5 Mb of free hardisk space.

The software is distributed on a single 3.5 inch diskette. The diskette contains all the files required to install and run the software.

Using either the Program Manager or the File Manager the user should select the floppy drive ( usually a:) and double click on the SETUP.EXE file. This program simplifies the installation of the software by copying the files from the diskette to the relevant directories on the hard disk.

When the setup program is running the user will be prompted to enter a destination directory for the software. A default directory is given as C:\AD9835. When the software is installed a Windows Group called Analog Devices will be created (Windows 3.1 only) and the AD9835 icon will be placed there. Double clicking on this icon will run the evaluation software. Windows 95 users can navigate through the directories using Windows Explorer and then double click on the AD9835.EXE file to start the software.

## The Evaluation Software

When the program starts it will check the PC BIOS to detect the address of the printer port installed. There are three possible base addresses at which a printer port can reside and these are shown below together with the printer names.

Printer	Base Address (hex)
LPT1	0x378
LPT2	0x278
PRN1	0x3BC

If there is more than one printer port installed the software will chose the first one it finds. It is possible to change the printer port from the software by clicking the Select Port button. The main screen for the evaluaton board software is shown in Fig. 3 below.

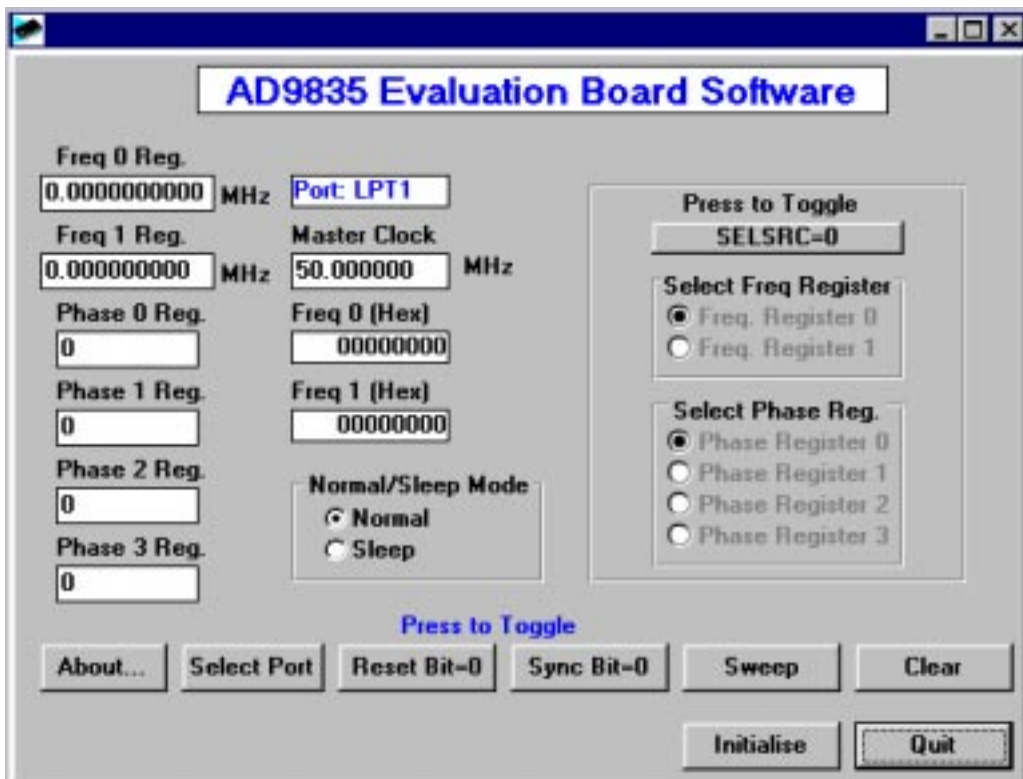

Figure 3: The Main Screen

## Features of the AD9835 Evaluation Board Software

The software allows the user to control all the functionality of the AD9835. The main features are listed below.

- Access to both Frequency 0 and Frequency 1 registers
- Access to the Phase Reg. 0, Phase Reg. 1, Phase Reg. 2 and Phase Reg. 3
- Access to Sleep, Reset and SELSRC bits.
- Ability to sweep through a frequency range using either the Frequency 0 or Frequency 1 registers.

Each of these features is described in detail in this application note.

## The Frequency Registers

The AD9835 contains 2 frequency registers which can be programmed individually. The software allows the user to enter any frequency value between 0Hz and half the master clock frequency. If a value outside this range is entered the software picks the closest valid value. The frequency value is converted to a 32 bit hexadecimal number which is loaded to the appropriate frequency register when the enter key is pressed. The hexadecimal number is also displayed on the main screen.

## The Phase Registers

The AD9835 contains four phase register which can be individually loaded with different values. The phase numbers are entered as integer values between 0 and 4095 (corresponding to 0° to 360° phase shift). Once again the values are loaded to the appropriate phase register when the enter key is pressed.

## Normal/Sleep Mode

The Control Register of the AD9835 contains a sleep bit to put the part into a power-down mode. When this bit is a logic 1 the internal clocks are disabled and the DAC's current sources and REFOUT are turned off. This bit can be controlled by the two radio buttons in the Normal/Sleep Mode box. The software defaults to Normal Mode reflecting the reset state of the AD9835.

## Reset Mode

The Reset bit in the Control Register of the AD9835 is controllable by the RESET button of the AD9835 Evaluation Board Software. Pressing this button toggles the state of the bit in the control register. Note that it is assumed that the RESET bit is low when the software is started. Setting the RESET bit to 1 will set the phase accumulator to zero phase corresponding to a full scale output.

## The SELSRC Bit

The SELSRC bit of the AD9835 is used to control the selection of the frequency and phase registers used to provide the output. If this bit is a zero the frequency and phase selection comes from FSELECT, PSEL0 and PSEL1 pins respectively. If the bit is a 1 then the registers are selected by software. Pressing the SELSRC button toggles this bit on the AD9835 and also enables or disables changing the frequency and phase registers from software as required.

It should be noted that since there is no readback facility on the AD9835 it is not possible to determine the contents of any register which has not been programmed by the software. For this reason selecting a frequency or phase register which hasn't been programmed may give an unpredicted output.

## The Sweep Facility

Pressing the Sweep button displays a new screen which can be used to program the AD9835 to produce a continuously increasing or decreasing frequency sweep. The user has the option of entering a start frequency, a stop frequency and a step frequency. There is also the option of setting the delay between steps and the number of time the sweep is to be repeated. If the user were to enter the sweep values shown below then the frequency outputs also shown below will be generated. Note that if the frequency span is not an integer multiple of the step frequency then the span from the second last frequency to the last frequency will be such that the stop frequency is the last frequency outputted to the AD9835.

<b>Start Freq.</b>	1.00000MHz
<b>Stop Freq.</b>	1.70000MHz
<b>Step Freq.</b>	0.20000MH

<b>Frequency Outputs:</b>	1.00000MHz
	1.20000MHz
	1.40000MHz
	1.60000MHz
	1.70000MHz

Both Frequency Register 0 and Frequency Register 1 can be loaded with separate frequency, step, delay and loop information but the output from the AD9835 will depend on which frequency register is selected via the FSELECT pin. If changing the frequency register is required then the user should ensure that the SELSRC bit is zero before starting the sweep.

## Additional Information

Information about the current version of software can be gathered from the About Screen (accessed by pressing the About button on the main screen).

# EVAL-AD9835EB

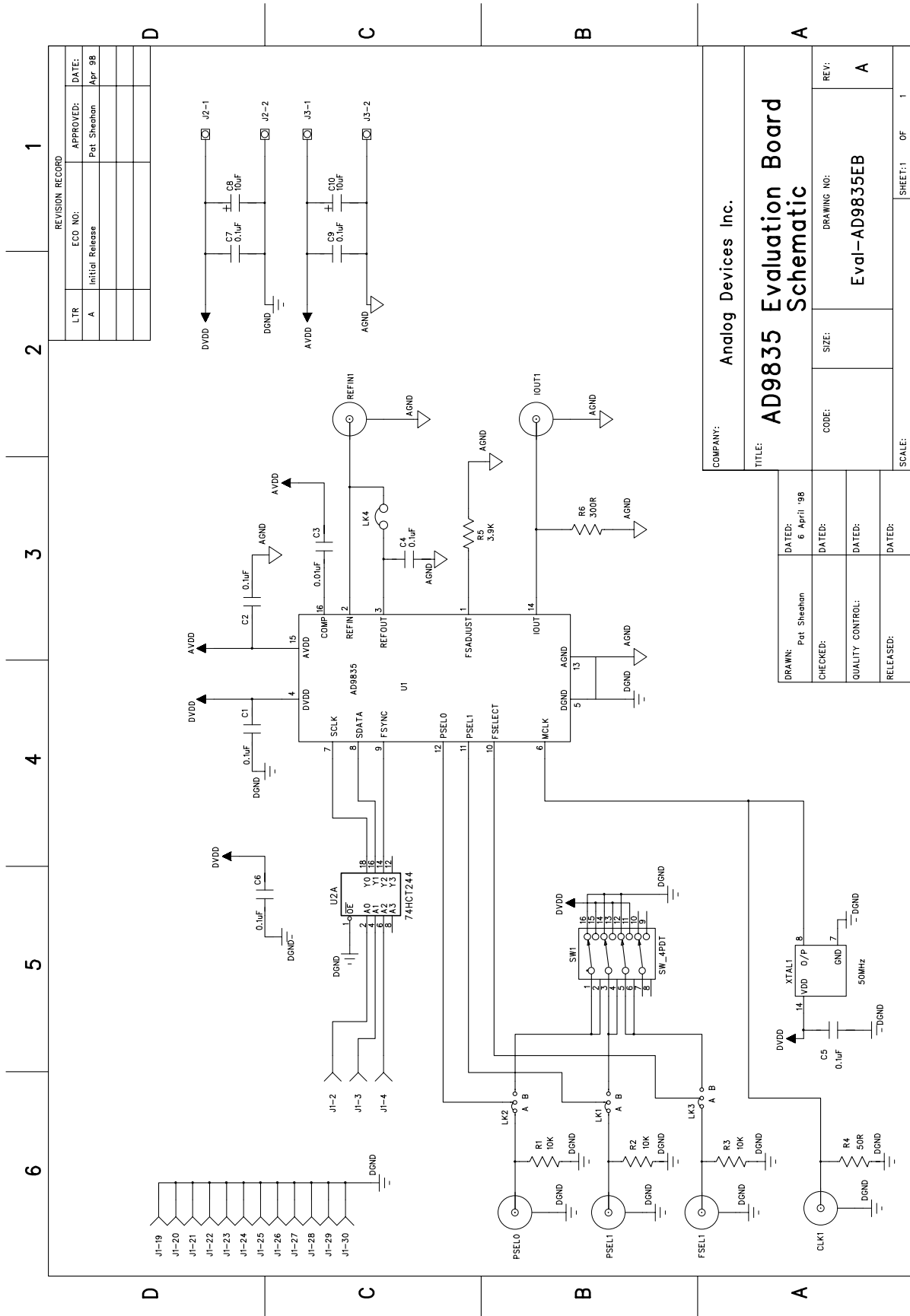
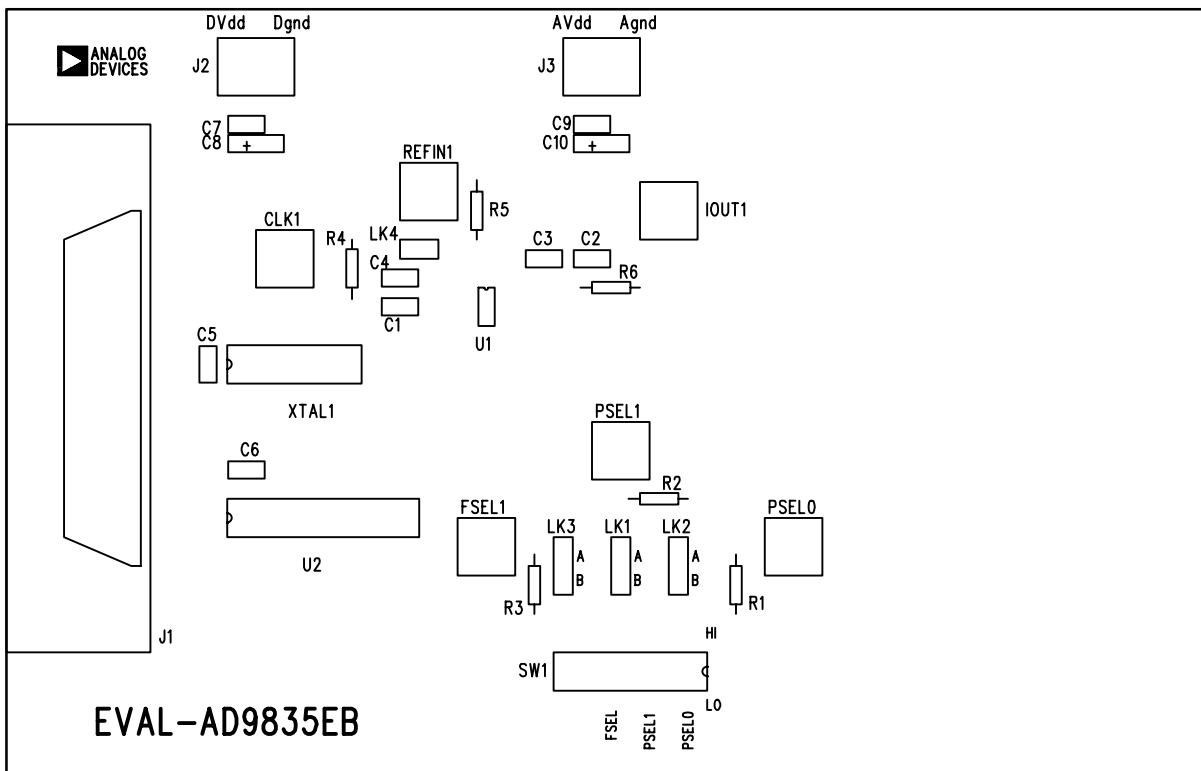

Figure 4: Eval-AD9835EB Schematic

**Table 5. Component Listing**

Item	Qty	Reference	Description	Supplier / No.
1	1	U1	AD9835	ADI AD9835
2	1	U2	74HCT244	FEC 382-267
3	1	SW1	Double throw end stackable switch	FEC 422-708
4	1	XTAL1	50MHZ CMOS/TTL Crystal	FEC 571-842
5	7	C1 C2 C4 C5 C6 C7 C9	100nF Ceramic Capacitor	FEC 146-227
6	1	C3	10nF ceramic Capacitor	FEC 146-224
7	2	C8 C10	10uF Tantalum Capacitor	FEC 643-683
8	3	R1 R2 R3	10KW Resistor	FEC 543-627
9	1	R4	51KW Resistor	FEC 543-070
10	1	R5	3.9KW Resistor	FEC 543-524
11	1	R6	300W Resistor	FEC 543-251
12	6	PSEL1 PSEL0 FSEL CLK IOUT REFIN	Sub Miniature BNC connector	FEC 299-844
13	1	J1	36 Way Centronics Connector	FEC 147-753
14	3	Lk1 Lk2 Lk3	3 pin sil header	FEC 528-432
15	1	Lk4	2 pin sil header	FEC 528-432
16	4	Lk1 Lk2 Lk3 Lk4	jumper	FEC 150-410
17	1	U2	20 pin dil solder socket	FEC 738-554
18	1	XTAL1	14 pin dil solder socket	FEC 738-529
19	1	J2 J3	Two Way Terminal Block	FEC 151-789
20	4	Rubber-Stick-On feet	Each corner	FEC 148-922



Eval-AD9835EB (Component Side View)

Silkscreen

**Figure 5. Eval-AD9835EB Silkscreen Artwork**

# EVAL-AD9835EB

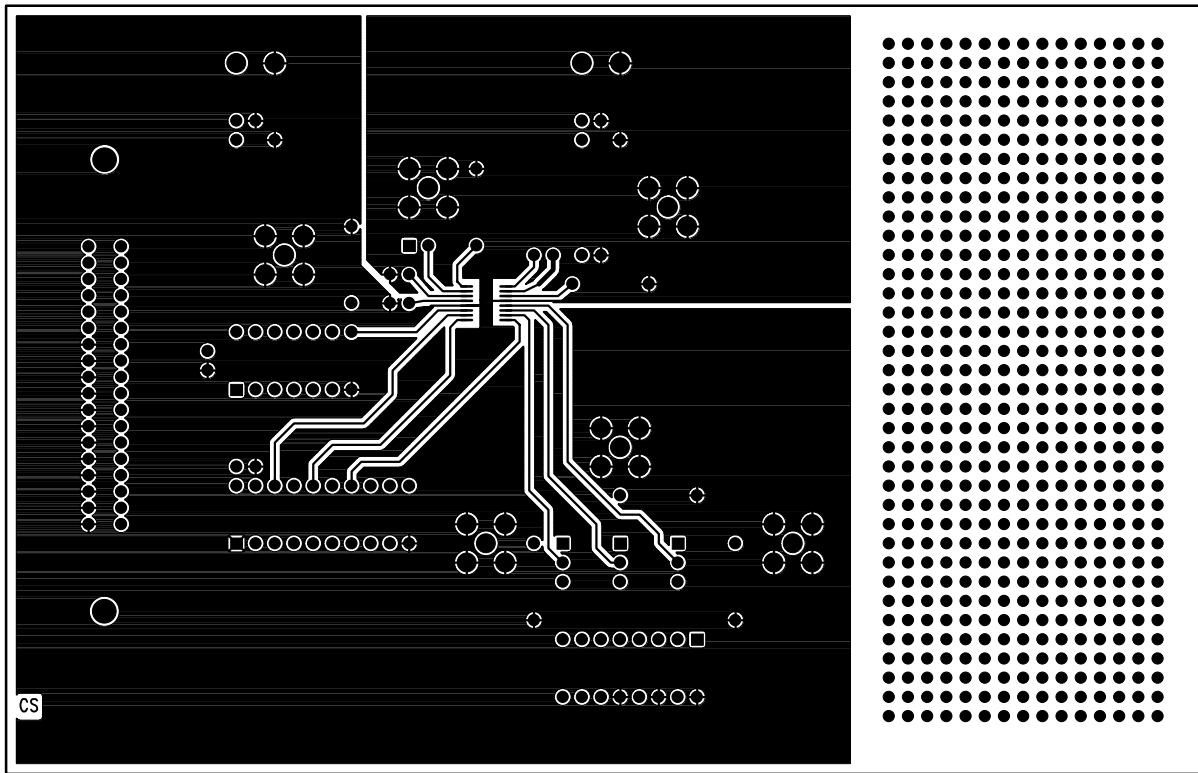

Eval-AD9835EB (Component Side View)

Component Side

*Figure 6. Eval-AD9835EB Component Side Artwork*

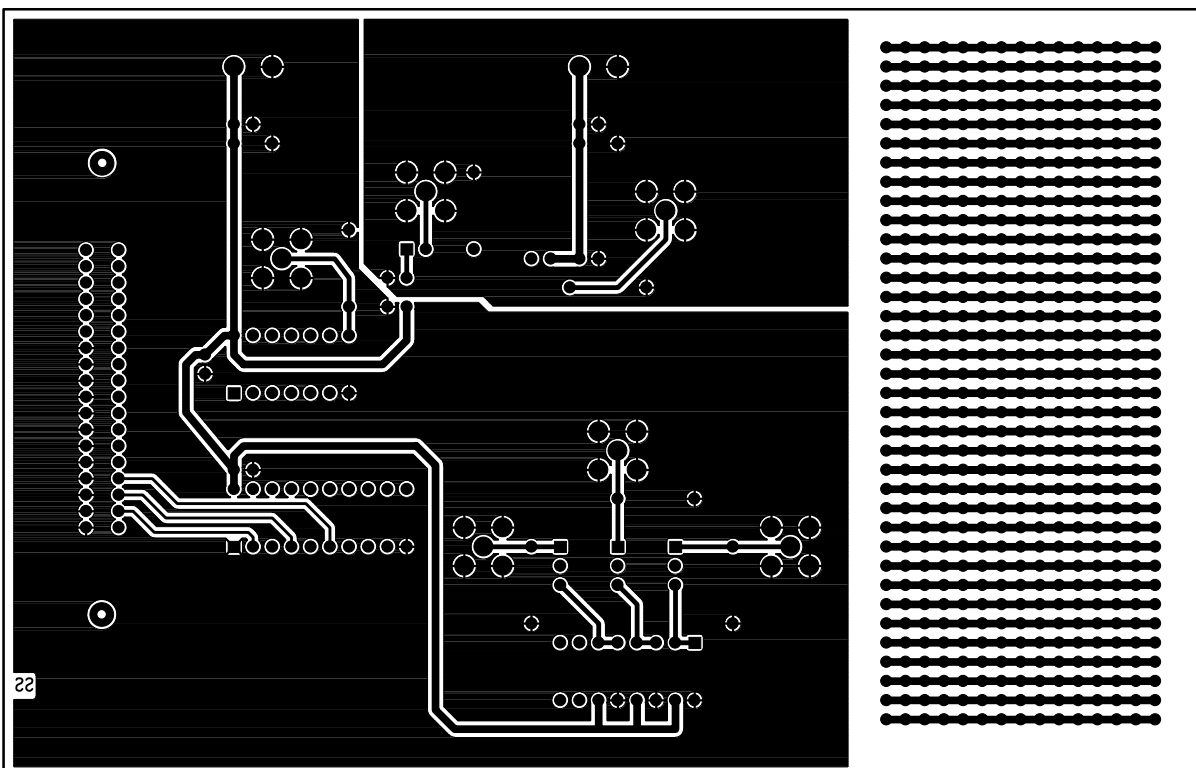

Eval-AD9835EB (Component Side View)

22

*Figure 7. Eval-AD9835EB Solder Side Artwork*