

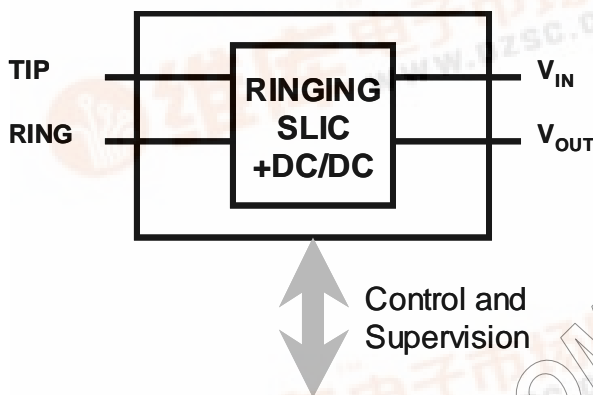

# Ag1160

## 5V RINGING SLIC



### FEATURES

- A highly featured SLIC in a 21 pin DIL format.
- Integral DC-DC converter. Single +5V supply voltage.
- Highly integrated with on board ringing generator.
- Tip/Ring polarity reversal, On-Hook Transmission for caller line ID.
- "Soft Shutdown" over current and thermal protection provides fail safe operation.
- Easy to use, with a minimum number of external components.
- Simplified protection in "on-premise" applications.
- Silver Telecom "design-in" assistance.

### DESCRIPTION

The Silver Telecom Ag1160 comprises a single Subscriber Line Interface Circuit (SLIC) in a 21 pin dual in line (DIL) format. The combination of features and packaging offers extremely efficient use of board area, saving significant system size and cost, minimising time to market for Telephony Systems developers.

The Ag1160 has been designed to work with loop lengths of up to 3.0km (800R including telephone). Its performance to regulatory standards allows use in public and private network applications.

The Ag1160 has integral dc/dc converter and ringing generation thus providing all the line

powering requirements from a single supply. The SLIC requires a minimum of external components.

The system interface has been designed for connection to all popular codecs of both the audio and signalling connections.

The Ag1160 is ideal for low line count, short loop length applications, such as ISDN Terminal Adaptors, Internet Telephony (VoIP), Computer Telephony Integration (CTI), Digital Loop Carriers (DLC), Wireless Local Loops (WLL) and Small Office Home Office (SOHO).

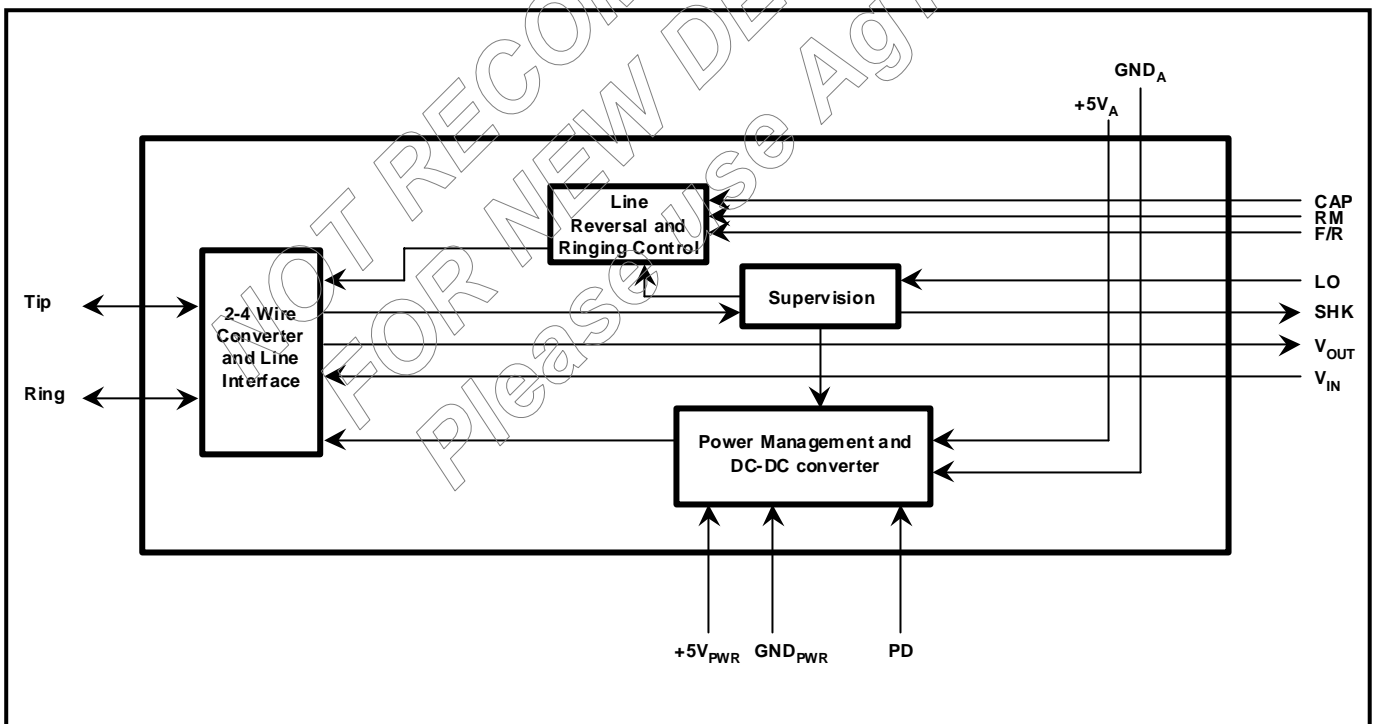



**Figure 1: Packaging Format**

**Ordering Information**

- Ag1160 5V Ringing SLIC, standard device
- Ag1160A 5V Ringing SLIC, low power
- Ag1160-48 5V Ringing SLIC, 48V line voltage
- Ag1160A-48 5V Ringing SLIC, 48V line voltage, low power



**Figure 2: Functional Block Diagram**

### Pin Description

Pin #	Name	Description
1	TIP (A)	<b>Tip.</b> Connects to the subscriber line Tip.
2	RING (B)	<b>Ring.</b> Connects to the subscriber line Ring.
3	NC	<b>No Connection.</b> This pin is not connected internally to the device.
4	PD	<b>Power Down.</b> A logic 1 powers off the DC-DC converter. Connect to logic 0 for normal operation.
5	NC	<b>No Connection.</b> This pin is not connected internally to the device.
6	LO	<b>Loop Off.</b> A logic 1 removes the loop current from the line. Connect to logic 0 for normal operation.
7	RM	<b>Ring Mode.</b> Sets bias conditions during ringing. Must be set to logic 1 during ringing.
8	GND <sub>A</sub>	<b>Analog Ground.</b> Normally connected to system ground.
9	+5V <sub>A</sub>	<b>Analog Supply.</b> This pin must be connected to the +5V supply via an RC filter, to supply power to the analog circuits.
10	NC	<b>No Connection.</b> This pin is not connected internally to the device.
11	NC	<b>No Connection.</b> This pin is not connected internally to the device.
12	NC	<b>No Connection.</b> This pin is not connected internally to the device.
13	V <sub>IN</sub>	<b>Audio In.</b> This is the analog input signal from the Codec (which is output on Tip and Ring). Connected via a 100nF capacitor.
14	CAP	<b>Slew Rate Capacitor.</b> A capacitor is fitted between this pin and GND to control the battery reversal and the ringing slew rate. 220nF is recommended.
15	V <sub>OUT</sub>	<b>Audio Out.</b> This is the analog output signal (from Tip and Ring) to the Codec. Connected via a 100nF capacitor.
16	F/R	<b>Forward/Reverse.</b> A logic 0 will reverse the Tip and Ring voltage polarities. F/R is toggled to produce the ringing output.
17	SHK	<b>Switch Hook.</b> Indicates an off-hook condition when at logic 1.
18	GND <sub>PWR</sub>	<b>DC-DC Ground.</b> Internal ground for the DC-DC converter.
19	V <sub>PWR</sub>	<b>DC-DC Supply.</b> +5V input for the DC-DC converter.
20	GND <sub>PWR</sub>	<b>DC-DC Ground.</b> Internal ground for the DC-DC converter.
21	V <sub>PWR</sub>	<b>DC-DC Supply.</b> +5V input for the DC-DC converter.

## 1.0 Line Interfacing

As well as being in an electrically demanding environment, the needs of different applications and regulatory standards means that the SLIC must allow flexibility, together with facilities to ensure robust performance. The Ag1160 SLIC provides a complete and flexible interface to the telephone line.

### 1.1 Battery Feed

The Ag1160 has an integral DC-DC converter, which generates the battery voltages in the device. This means that only a supply of +5V, and GND is needed, unlike conventional SLICs, which will need a battery voltage of anything between -20V and -60V (-75V for ringing). This confers a significant cost, space and time to market benefit on the equipment designer.

The battery feed to the telephone line is generated from the positive supply rail. This provides a -36V battery feed to the line driver (-24V for Ag1160A), except during ringing, when this is increased to -72V. For applications, which require -48V feed voltage during the on hook state (eg. some fax machines), a bleed resistor can be provided. However this will increase the idle current.

The Ag1160A is designed for use in low power short loop applications, and provides a battery feed of -24V to the line.

The loop current is pre-set to a constant 24mA. If the loop length is such that the constant current feed cannot be maintained (i.e. >3km, or 0.5km for Ag1160A), then the Ag1160 will revert to a constant voltage source, allowing the loop to be serviced at a reduced loop current.

### 1.2 Ringing

The ringing signal is generated by switching the SLIC into ringing mode by setting the RM pin high and then toggling the F/R pin at the required frequency and cadence. The toggling of the F/R pin produces a balanced signal at Tip and Ring. These signal waveforms are shown in Figure 3.

During ringing the integral DC-DC converter automatically switches to produce a battery voltage of -72V. This will produce greater than 40V rms into a REN of 3. The slope of the edges on the ringing waveform is determined by the value of the slew rate capacitor connected between the CAP pin and Ground. A 220nF capacitor is recommended with 20Hz ringing.

When an "off-hook" condition occurs during ringing, the ring-trip circuit on the Ag1160 senses the loop current flowing and signals the off-hook condition on the SHK

output. The SHK signal must be "debounced" to remove any spurious pulses by the controlling processor. On detection of SHK the ringing signal must be removed from the F/R pin and RM taken to a logic 0 within 500ms to avoid excessive power dissipation in the line driver circuit. The ring-trip function will operate correctly up to a maximum loop resistance of around 800R (including telephone), which corresponds to around 3km loop length. It is recommended that a 10K pull-down resistor is fitted to RM.

### 1.3 Loop Off and Power Down

The loop current can be removed from the line by switching the LO input to a logic 1. This can be used as a power denial to the line or to present a very high impedance to the line. Typically used when carrying out maintenance on the line, or to suspend service during a line fault, etc.

The DC-DC converter can be switched off by applying a logic 1 to the PD input. This reduces the current consumption to a nominal 15mA. The SLIC takes 50ms to power up from this powered down state. When using the power down state it is recommended that the SLIC is polled (powered up periodically) to check for SHK (the subscriber has gone off hook).

## 2.0 The 2-4 Wire (hybrid) Conversion.

The Ag1160 SLIC transmits and receives balanced 2-wire analog signals at the Tip and Ring connections. These are converted to a ground referenced output at  $V_{OUT}$  and from a ground referenced input at  $V_{IN}$ .

$V_{OUT}$  and  $V_{IN}$  are normally connected to a Codec for conversion to and from a digital Pulse Code Modulated (PCM) stream.

### 2.1 Transmit and Receive Gain.

The gain in both the transmit direction (Tip/Ring to  $V_{OUT}$ ) and the receive direction ( $V_{IN}$  to Tip/Ring) is set to 0dB. Normally any gain adjustments required by the user can be made by programming the Codec.

### 2.2 The 2 Wire Impedance.

The input impedance (at Tip/Ring),  $Z_{in}$ , of the SLIC is set to 600R. For countries where the line impedance is 600R e.g. North America, no external adjustment is required. For countries where an alternative line impedance is used the Codec filter characteristics can be programmed to give the required matching.

The Codec manufacturer can provide information on how Codec programming is done. Programmable

Codecs require information about the transfer characteristics of the SLIC with which they are working. Some codecs require a .CIR netlist. A .CIR netlist can be obtained by contacting either Silver Telecom or your local representative, to allow certain Codec programming coefficients to be generated.

If a simple (non-programmable) Codec is being used contact Silver Telecom for an Ag1160 version with an alternative impedance.

**2.3 Network Balance Impedance.**

The network balance impedance, Z<sub>b</sub>, of the SLIC is set to 600R for the standard Ag1160. For countries where the network balance impedance is 600R e.g. North America, no external adjustment is required. For countries where an alternative network balance impedance is used the Codec filter characteristics can be programmed to give the required matching. The .CIR netlist may be needed to allow the Codec programming coefficients to be generated.

If a simple (non-programmable) Codec is being used contact Silver Telecom for an Ag1160 version with an alternative impedance.

**2.4 Tip & Ring Polarity Reversal.**

The Ag1160 can reverse the battery voltage polarity at Tip and Ring via the F/R pin.

If F/R is held at logic 1 (forward) the d.c. voltage at Tip is positive with respect to Ring. If F/R is taken to logic 0 the voltage polarity is reversed. The F/R pin should not be left floating, and if not used should be tied high as shown in Figure 4.

**2.5 On Hook Transmission.**

The Ag1160 is capable of on-hook transmission. This means analog signals can be transmitted from V<sub>IN</sub> through Tip and Ring and onto the line even when no loop current is flowing. This can be used when

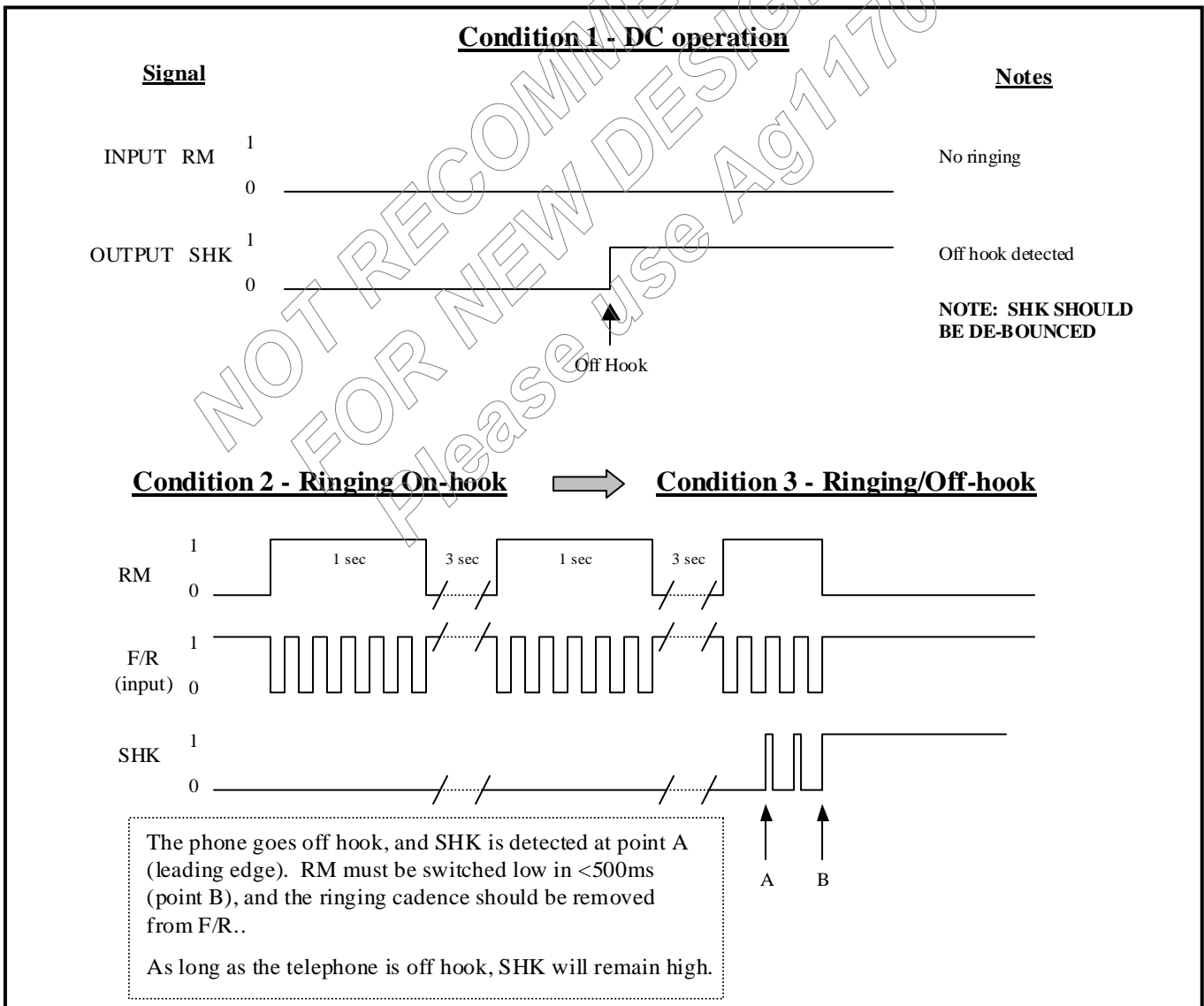

**Figure 3: Ringing Signal Waveforms**

sending Caller Line Identification (CLI) information or for other “no ring” calls.

The Ag1160 will provide on hook transmission with a high impedance on Tip/Ring or specific loads are demanded by Network Operators.

### 3.0 Switch Hook Detect Level

When the subscriber goes “off-hook” loop current will begin to flow. If this current is above the detection threshold (10mA) the switch hook output, SHK, will switch to a logic 1. It is recommended that software or hardware de-bouncing of the switch hook signal is used. This is to avoid short pulses which can cause a false switch hook output, triggering the incorrect system response.

During loop disconnect dialling, SHK will pulse between logic 1 and logic 0 to indicate the digits being dialled. Again it is recommended that software de-bouncing is used to avoid false detection of digits.

### 4.0 Protection of the Ag1160 SLIC

#### 4.1 Thermal Protection

Should the SLIC be operated incorrectly, for example by accidentally shorting Tip and Ring to each other or to ground, there is a danger the power dissipation

could exceed the 1.6W maximum rating. In this case a thermal cut-off will ensure the device gradually powers down safely by reducing the loop current. Once the problem has been corrected the loop current will return to its normal level.

This feature means that the SLIC can be used even when a thermal overload has occurred.

#### 4.2 Lightning and Power Cross Protection.

It is usual for the Ag1160 to be used in “on-premise” applications, such as SOHO, CTI and VoIP. In this case power cross and lightning protection is not required, however in most ‘off-premise’ applications, a subscriber circuit will be required to withstand over voltage conditions which could be caused by lightning or overhead power cables striking the telephone cables. It is therefore normal in “off-premise” applications to provide primary and secondary protection circuits to prevent damage to the SLIC.

The Ag1160 has been designed to be able to use low cost protection components and a typical circuit is shown in Figure 5. This circuit is suitable for most “on-premise” applications.

With some additional components, the Ag1160 will meet UL1459 and 1950 requirements: a series element should be added - a combination of a fuse (e.g. 350mA, Bussman C515 or Littelfuse 220003) and a

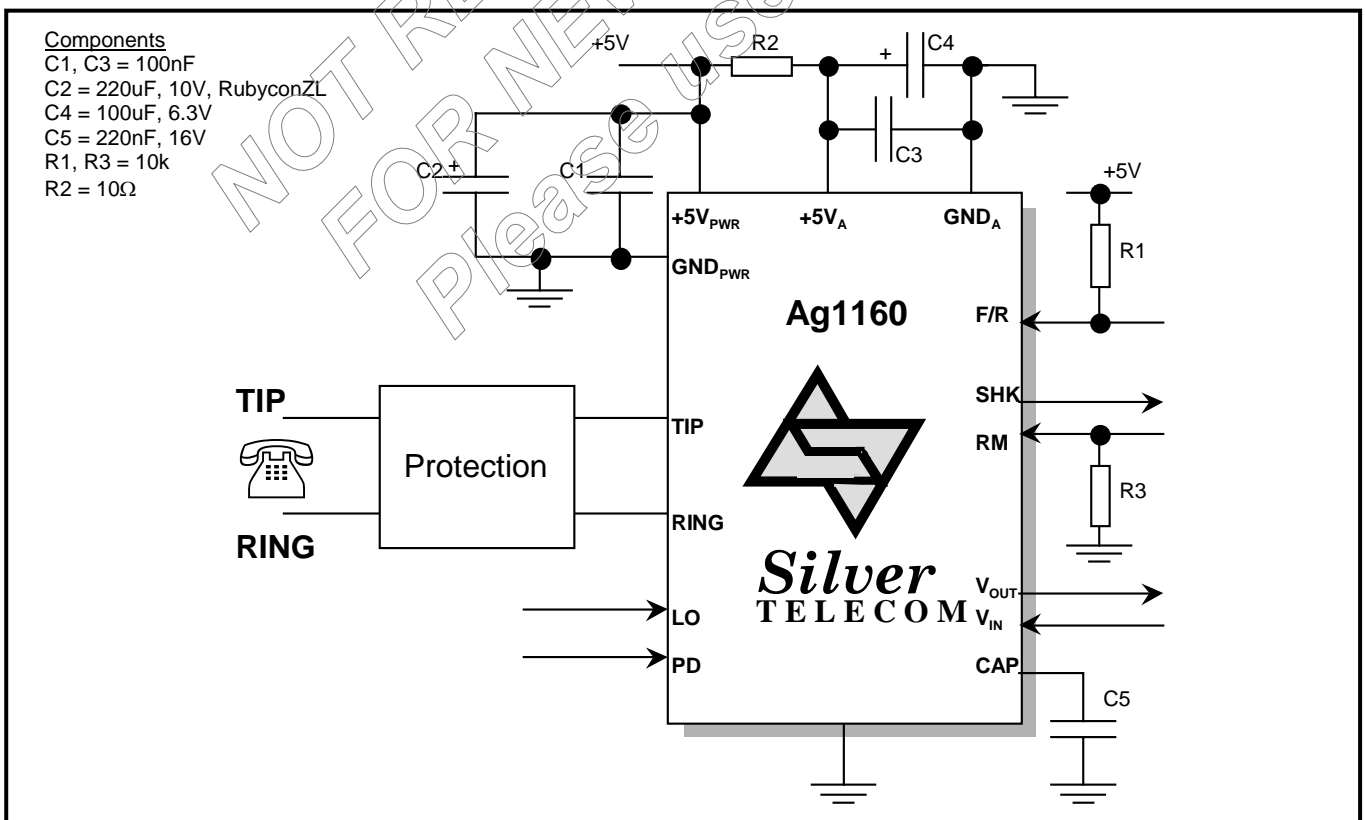

**Figure 4: Typical Connection Diagram.**

surge resistor (25R typically). Alternatively a Teccor F1250T or F0500T fuse may be used without a surge resistor.

For ITU-T K20 power cross protection, a PTC thermistor (eg. type JH330L) of 30R is suitable. The lightning protection is provided by steering diodes connected to 0V and upgrading D1 to a Tranzorb device (Motorola or STM 1.5KE82A). For lightning and power cross protection, D1 should be upgraded further (General Semiconductor or Semitron 5KP75). Just one Tranzorb is needed per linecard.

### 5.0 Approvals.

It can be seen from the Electrical Characteristics given on subsequent pages that the SLIC has been designed to meet the equipment standards of as many major public telephone authorities as possible.

It is the responsibility of the equipment design authority to ensure that their system meets the requirements of the relevant regulatory bodies. Every effort is made to ensure that Silver Telecom products are compliant with the latest standards.

### 6.0 A Typical Application.

The Ag1160 has been designed to interface to any Codec and is shown in a typical application in Figure 5.

The Codec which has been chosen to illustrate the use of the Ag1160 is the Motorola MC14LC5480.

The status outputs from the SLIC are passed to the micro-controller. These signals can then be processed as necessary by the system software.

The audio signals which are on the 4 wire side of the connection are coupled by 100nF capacitors to avoid d.c. level problems between the two devices.

The Ag1160 provides for a 2 wire impedance and a network balance impedance of 600Ω. For other impedances a DSP codec can be used which can be programmed using applications information available from the codec manufacturer. The necessary transfer function parameters for the Ag1160 are available from Silver Telecom.

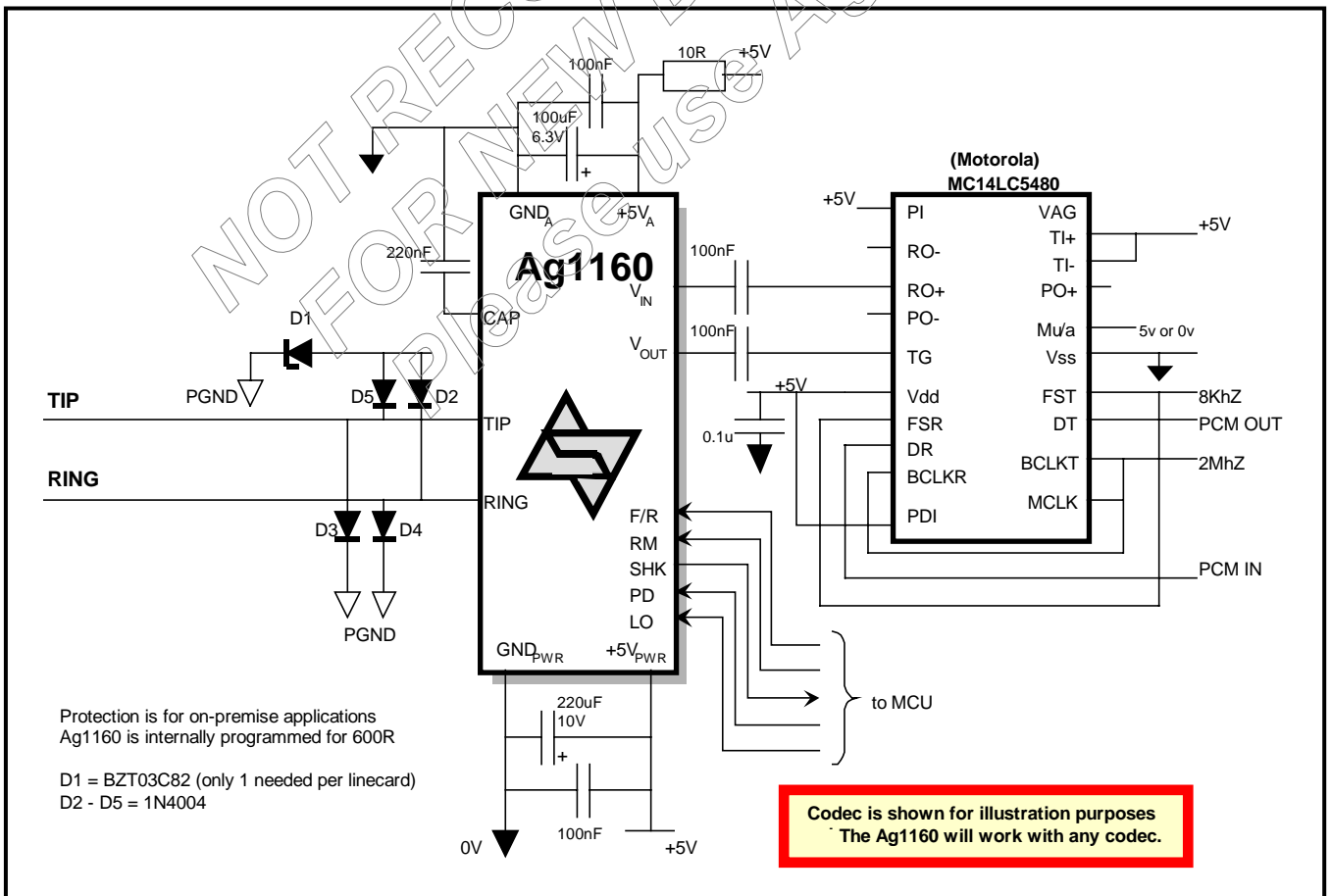
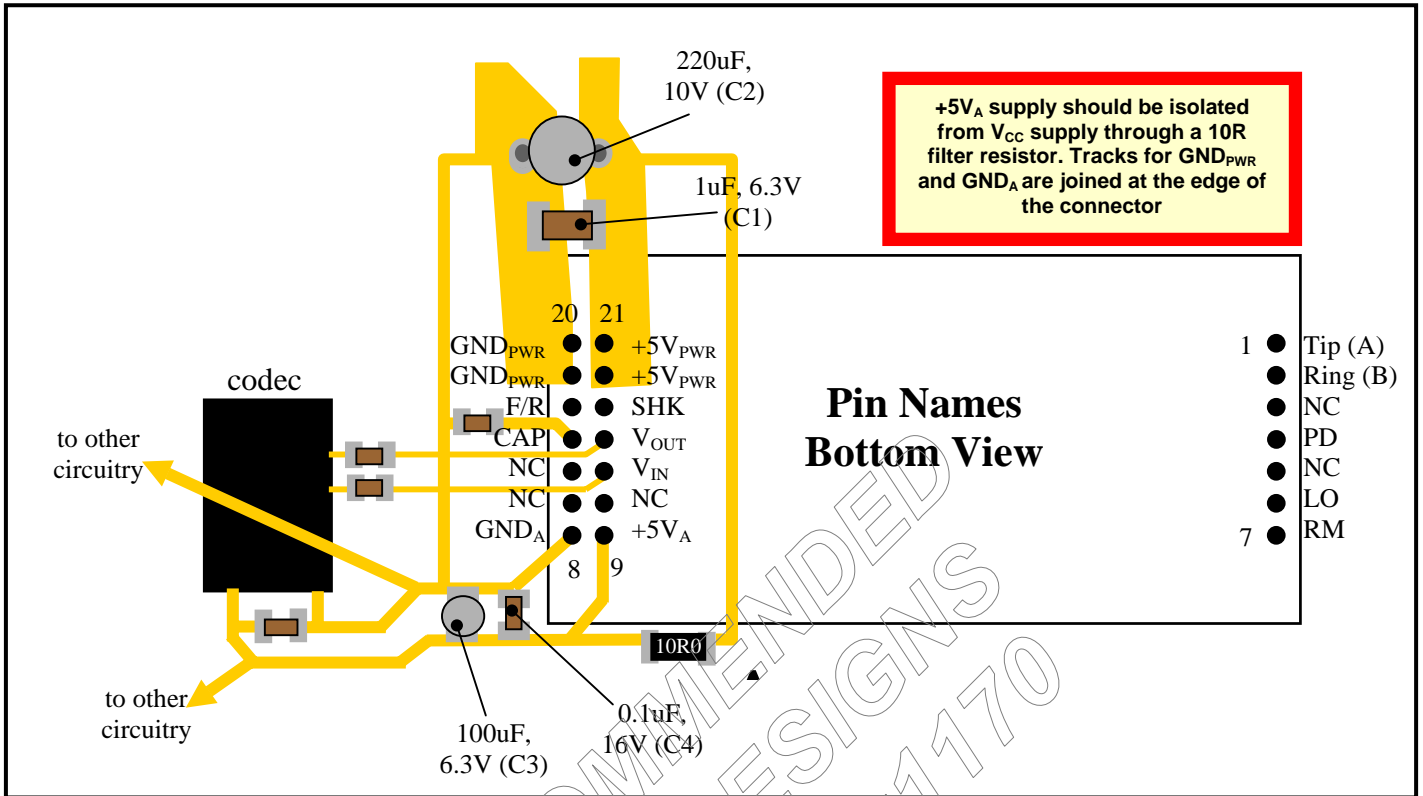

Figure 5: Typical On-Premise Application.



**Figure 6: Layout Considerations.**

If a simple Codec, without programmable filtering characteristics, is to be used, Silver Telecom can provide the Ag1160 with different impedances. Contact Silver Telecom for other applications circuits.

### 7.0 Layout Considerations.

Figure 6 gives an example of the tracking needed for the Ag1160. Tracks to the +5V<sub>PWR</sub> and GND<sub>PWR</sub> should be made as thick as possible. Also to maximise the performance of the device signal tracks should be kept as short as possible. Finally as is common in all designs, decoupling capacitors should be placed adjacent to the supply and ground pins.

It is important that a low ESR, high quality capacitor is used for C2. The Rubycon ZL is recommended.



## 8.0 Electrical Characteristics.

### 8.1 Absolute Maximum Ratings\*

All Voltages are with respect to ground unless otherwise stated.

	Parameter	Symbol	Min	Max	Units
1	DC Supply Voltage	$V_{CC}$	-0.3	5.5	V
2	Maximum Power Dissipation, Off Hook @ 25°C	$P_{SLIC}$		1.8	W
3	Storage Temperature	$T_s$	-40	+100	°C

\*Exceeding the above ratings may cause permanent damage to the product. Functional operation under these conditions is not implied. Maximum ratings assume free air flow.

### 8.2 Recommended Operating Conditions\*

All Voltages are with respect to ground unless otherwise stated.

	Parameter	Symbol	Min	Typ	Max	Units
1	DC Supply Voltage	$V_{CC}$	4.75	5.0	5.25	V
2	Operating Temperature	$T_{OP}$	0	25	70	°C

\*Typical figures are at 25°C with nominal +5V supplies and are for design use only.

NOT RECOMMENDED  
FOR NEW DESIGNS  
Please use Ag1170

### 8.3 DC Electrical Characteristics.

	Characteristic	Sym	Min	Typ*	Max	Units	Test Comments
1	Supply Current, on-hook Ag1160 Ag1160A	$I_{IDLE}$	120 80	140 110	160 130	mA mA	
2	Supply current ringing 1 REN Ag1160 Ag1160A	$I_{RINGING}$		300 300		mA mA	$R_{LOOP} = 1$ REN
3	Supply current, off-hook Ag1160 Ag1160A	$I_{ACTIVE}$		350 270		mA mA	$R_{LOOP} = 300\Omega$
4	Supply current during ring trip (<1 sec max) Ag1160 Ag1160A			700 700		mA mA	$R_{LOOP} = 300\Omega$
5	Supply current in power down	$I_{PD}$		15		mA	
6	Wake-up time			50		ms	
7	Constant current feed to line Ag1160 Ag1160A	$I_{LOOP}$	21.5 19.5	24 22	26.5 24.5	mA mA	$R_{LOOP} = 500\Omega$ $R_{LOOP} = 380\Omega$
8	Tip/Gnd or Ring/Gnd or Tip&Ring/Gnd overcurrent				35.0	mA	
9	Off-Hook detect Output Low Voltage Output High Voltage	$V_{OL}$ $V_{OH}$	3.15		0.9	V V	@ 0.4mA @ -0.4mA
10	Off-Hook detect Output Low Voltage Output High Voltage	$V_{OL}$ $V_{OH}$	3.5		0.4	V V	@ 50 uA @ -50 uA
11	Control Inputs, F/R, LO, PD, RM Input Low Voltage Input High Voltage	$V_{IL}$ $V_{IH}$	4.0		0.3	V V	
12	Control Inputs, F/R, LO, PD, RM Input low current Input high current	$I_{IL}$ $I_{IH}$	-0.5		0.5	mA mA	
13	Switch Hook Detect Threshold			10.0		mA	
14	Load on $V_{OUT}$		10.0			kohm	

1) All DC Electrical Characteristics are over the Recommended Operating Conditions with  $V_{CC}$  at +5.0V  $\pm 5\%$ , unless otherwise stated.

2) Operating currents are dependent on the user's application.

\*Typical figures are at 25°C with nominal 5V supply and are for design aid only.

### 8.4 AC Electrical Characteristics.

	Characteristic	Sym	Min	Typ*	Max	Units	Test Comments
1	SHK Detect Time			5.0		ms	No Ringing
2	Ring Trip Capability			3.0		km	
3	Input Impedance at $V_{in}$			100		kohm	
4	Output impedance at $V_{out}$				10	ohm	
5	Ringing Capability 40V <sub>rms</sub> into REN=3 40V <sub>rms</sub> into REN=1	D <sub>RING</sub>			2.8 3.0	km km	With 24 AWG loop
6	Absolute Voltage Gain, 2 Wire to $V_{out}$		-0.5	0	0.5	dB	Off-Hook
7	Absolute Voltage Gain $V_{in}$ to 2Wire		-0.5	0	0.5	dB	Off-Hook
8	Relative Gain, Referenced to 1kHz. 2Wire - $V_{out}$ , $V_{in}$ - 2Wire		-0.25		0.25	dB	Over frequency range 300 to 3400 Hz
9	Total Harmonic Distortion @ 2Wire and $V_{out}$	THD		0.1	1.0	%	@0dBm, 1kHz
10	Overload Distortion @2 Wire and $V_{out}$	OD		0.5	5.0	%	@+3dBm, 1kHz
11	Common Mode Rejection Ratio @ 2 Wire	CMRR	40	46		dB	200-3400Hz
12	Idle Channel Noise	N <sub>c</sub>		8.0	12.0	dBnC	@2 Wire & V <sub>OUT</sub>
13	Power Supply Rejection Ratio at 2 Wire and $V_{out}$	PSRR	25	32		dB	Ripple 0.1V, 1kHz on V <sub>cc</sub>
14	Return Loss	RL	18	35		dB	200-3400Hz
15	Transhybrid Loss	THL	18 21	35 35		dB dB	200-3400Hz 500-2500Hz
16	Load on $V_{out}$		10.0			kohm	Coupling capacitor = 100nF
17	Longitudinal to Metallic Balance		46	53		dB	200-3400Hz
18	Tip-Ring Reversal Settling Time				50	ms	To within +20% of set I <sub>LOOP</sub>

3) All AC Electrical Characteristics are over the Recommended Operating Conditions with V<sub>cc</sub> at +5.0V ±5%, unless otherwise stated.

4) Gain, Transhybrid Loss and Total Harmonic distortion parameters measured with 600Ω termination.

\*Typical figures are at 25°C with nominal 5V supply and are for design aid only.

### 10.0 Mechanical Specification

