

ASAHI KASEI

[AK2570]

**AK2570****Feed Forward APC LSI for LD Module**

DESCRIPTION

AK2570 is the monolithic CMOS LSI has the function of 'Feed Forward Automatic Power Control (APC)' for the Laser Diode (LD) module and maintains the emission intensity of the LD module constant with the high accuracy.

For stabilizing the emission intensity of the LD module affected by the ambient temperature, AK2570 feeds the compensation voltage from the 2channels - 8bits D to A converter to control the Bias- and the Modulation- current for the LD module. The compensation voltage corresponds to the temperature characteristic data of the LD module retained in the on-chip EEPROM and the ambient temperature detected by the on-chip thermo-sensor.

AK2570 outputs the alarm signal for the weakened LD emission caused by the aging degradation with comparing the alarm threshold level and the signal from the monitoring Photo Diode (PD).

The data of the compensation voltage and the alarm threshold level retained in the on-chip EEPROM can be set to suit for the characteristics of each LD module.

FEATURE

- Realizing all APC function on 1 silicon chip
- Controlling the driving current (the Bias- and the Modulation- current) for the LD module
 - * Consisting of the 2channels - 8bits D to A converter and the Op-amp
- EEPROM (Electrically Erasable Programmable Read Only Memory)
 - * The Non-volatile Memory
 - * The memory capacity : Address 9bits × Data 16bits
 - * Retaining the data of the compensation voltage and the trimming data of the T-SENSE offset voltage and the ALM timing for each LD module
- On-chip Thermo-sensor (T-SENSE)
 - * Detecting the ambient temperature and converting the detected temperature to the voltage
- On-chip Alarm circuit
 - * Outputting the alarm signal for the weakened LD emission caused by the aging degradation
- On-chip Oscillator
- On-chip Power on reset circuit
- Serial interface
- +3.3V±10% single voltage supply
- Low power consumption (30mA [max])
- Small package (20pin - SSOP : 7.9mm ×7.4mm)



AK2570 consists of these circuit blocks as below.

Circuit block	Functional description
Oscillator	This circuit generates the standard clock that settles the timing for the sequence of the internal circuit in “Self-operation mode (Ordinary mode)”.
VREF	This circuit generates the reference voltage for the A to D converter, the D to A converter and the T-SENSE.
T-SENSE	This circuit is the thermo-sensor, outputs the voltage corresponding to the ambient temperature, i.e. the temperature to voltage converter, and transfers this output voltage to AD2. Also it integrates the offset adjustment circuit that cancels the distribution.
AD1	The A to D converter encodes the input voltage at VPDIN-pin (the signal from the monitor PD) to the 8bits digital data. It is possible to read the encoded data of monitor PD signal (the reference data for RDA3) held in RVPD register and to set the alarm threshold level for the degraded LD in “Training mode”.
AD2	The A to D converter encodes the T-SENSE output signal to the 8bits digital data. In “Self- operation mode”, the encoded data of the ambient temperature detected by the T-SENSE is converted to the EEPROM address and utilized for reading the temperature characteristic data of the LD retained in the EEPROM. In “Training mode”, it is possible to read the encoded data of the detected temperature held in RTMP register.
DA1, AMP1	This block consists of the D to A converter and the Op-amp and controls the Bias- or the Modulation- current for the LD. DA1 decodes the 8bits digital data held in RDA1 register to the compensation voltage for the temperature drift of the LD. Inputting the ‘H’ level signal to SHUTDOWN-pin makes that DAOUT1-pin outputs ‘0V (min.)’.
DA2, AMP2	This block consists of the D to A converter and the Op-amp and controls the Bias- or the Modulation- current for the LD. DA2 decodes the 8bits digital data held in RDA2 register to the compensation voltage for the temperature drift of the LD. Inputting the ‘H’ level signal to SHUTDOWN-pin makes that DAOUT2-pin outputs ‘0V (min.)’.
DA3, ALMOUT, Comparator, ALM Timing Generator	This block outputs the ‘H’ level alarm signal from ALM-pin in the case that the monitoring PD signal becomes lower than the alarm threshold level retained in the EEPROM and held in RDA3 register, and this case is caused by the aging degradation.
EEPROM	This memory is the non-volatile memory, has the capacity ‘Address 9bits × Data 16bits’ and retains the data as below, <ol style="list-style-type: none"> 1. The temperature compensation data for the LD (transferred to RDA1 and RDA2 registers) and the alarm threshold level data for the degraded LD (transferred to RDA3 register) corresponding to the ambient temperature (the output from the T-SNESE and AD2). 2. The trimming data for the T-SENSE offset and the ALMOUT timing.
Register	This circuit temporarily stores the ambient temperature data (in RTMP register), the temperature compensation data for the LD (in RDA1 and RDA2 registers), the alarm threshold level data (in RDA3 register) and so on.
Control	This circuit controls the internal circuit, e.g. registers, with the serial interface.
Power on Reset	At ‘Power ON’, this circuit initializes the data in all registers (see p.9) and sets AK2570 in “Self-operation mode”.

PIN ASSIGNMENT



No	Name	I/O	Type	Function	AC load	DC load	Remark
1	TEMPTEST	O	Analog	Output the voltage generated by the T-SENSE (Factory use)			
2	BIAS	O	Analog	Output the current reference determined by the external resistance			[Note 1]
3	FB1	I	Analog	Input the feed back voltage to AMP1 for the gain control			
4	DAOUT1	O	Analog	Output the compensation voltage [1] for the LD	< 20pF		
5	FB2	I	Analog	Input the feed back voltage to AMP2 for the gain control			
6	DAOUT2	O	Analog	Output the compensation voltage [2] for the LD	< 20pF		
7	AVDD	I	Power	Supply the power for the analog part (+3.3V)			
8	AVSS	I	Power	Ground the analog part (0V)			
9	VPDIN	I	Analog	Input the signal of the monitor PD			
10	ALM	O	CMOS	Output the aging alarm	< 20pF		
11	ENVIN	I	CMOS	Input the envelope signal used at burst transmission			
12	CS	I	CMOS	Input the Chip Select signal with the serial interface			[Note 2]
13	SK	I	CMOS	Input the Shift clock with the serial interface			
14	DI	I	CMOS	Input the Data with the serial interface			
15	DO	O	CMOS	Output the Data with the serial interface	< 100pF		
16	DVSS	I	Power	Ground the digital part (0V)			
17	DVDD	I	Power	Supply the power for the digital part (+3.3V)			
18	SHUTDN	I	CMOS	Input the shut down signal for DA1 and DA2			See P.15
19	ALMMOD1	I	CMOS	Input the select signal [1] for the aging alarm mode			See P.15
20	ALMMOD0	I	CMOS	Input the select signal [0] for the aging alarm mode			See P.15

[Note 1] : Kindly insert the external register 75kΩ (±1%) between BIAS-pin and AVSS.

[Note 2] : It is necessary to input the 'L' level signal to CS-pin at 'Power ON'.

FUNCTIONAL DESCRIPTION

1. Explanation for the ‘mode’

AK2570 has the 2 operational modes, “Self-operation mode” and “Training mode”.

After executing the evaluation and the adjustment for the LD module including AK2570 in “Training mode”, it is possible to use AK2570 ordinarily in “Self-operation mode” for compensating the temperature drift of the LD module.

“Self-operation mode” is the ordinary operational mode. If the ambient temperature drifts, AK2570 can maintain the emission intensity of the LD module constant by executing the APC operation, i.e. controlling the Bias- and the Modulation- current for the LD module, periodically (the compensation period is about 100msec) in “Self-operation mode”. (See p.6) On the other hand, in “Training Mode”, it is possible to evaluate and adjust AK2570 and the LD module by the access to the data in the EEPROM and the registers. (See p.7)

[a] Constitution of the mode and the command

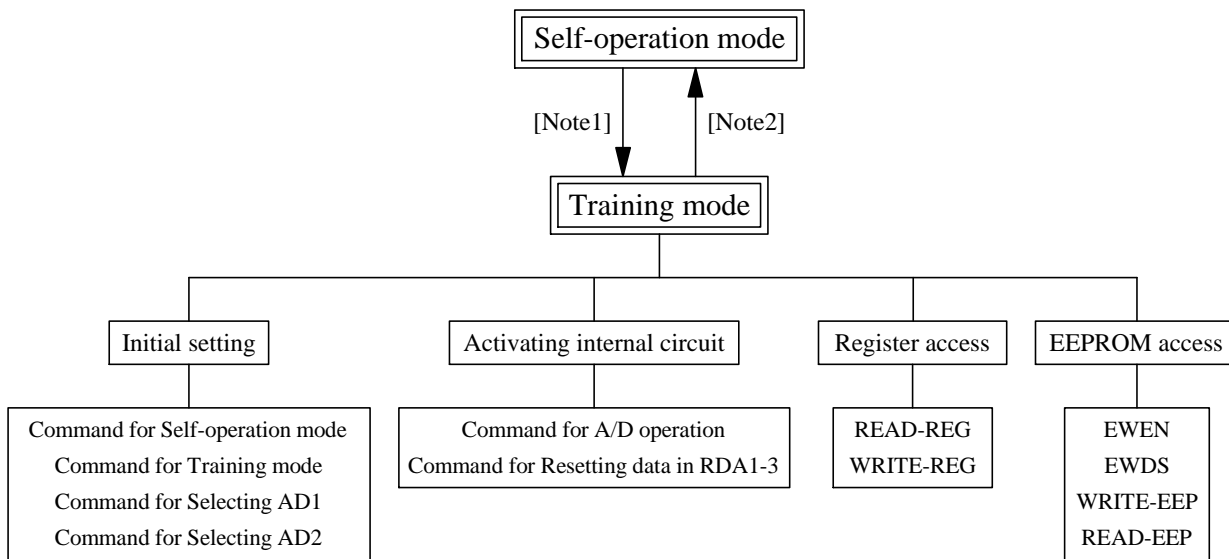

[Note 1] While operating in “Self-operation mode”, it is possible to shift to “Training mode” by executing ‘Command for Training mode’ and this is the only available command. That is to say that any other command is not effective in “Self-operation mode”.

[Note 2] On the other hand, while operating in “Training mode”, it is possible to shift to “Self-operation mode” by executing ‘Command for Self-operation mode’ or forcing the ‘L’ level signal to SK-pin for 50ms more and AK2570 shifts to “Self-operation mode” with behaving as same as the operation at ‘Power ON’.

[b] Explanation for the modes and the commands

(1) Self-operation mode

The on-chip 'Power on Reset' circuit initializes the data in all registers and sets AK2570 in "Self-operation mode" automatically at 'Power ON'. In "Self-operation mode", AK2570 operates as below and keeps the emission intensity of the LD module constant by periodically applying the compensation voltage for the Bias- and the Modulation- current against the temperature drift of the LD module.

In 50msec after the end of the resetting operation at 'Power ON', the data in EEPROM (Address = '1 1111 1111 [EINT memory]') is transferred to RINT and RATRM registers. Notice that the data in these registers can not change except the case of executing 'Power ON' again or re-writing the data with executing 'WRITE-REG' command in "Training mode".

In "Self-operation mode", the T-SENSE converts the detected ambient temperature to the voltage. AD2 encodes this voltage to the 8bits digital data and transfers this data to RTMP register. This data is converted to the EEPROM address and utilized for reading the temperature characteristic data of the LD retained in the EEPROM. The EEPROM data is transferred to RDA1 ~ RDA3 registers and the output voltage of DA1 ~ DA3 are controlled. It is realized that the constant emission intensity of the LD is independent with the temperature drift by controlling the Bias- and the Modulation- current for the LD module and the alarm signal for the weakened LD. This behavior is executed periodically (the period is about 100ms). While operating in "Self-operation mode", it is impossible to execute any command except 'Command for Training mode'.

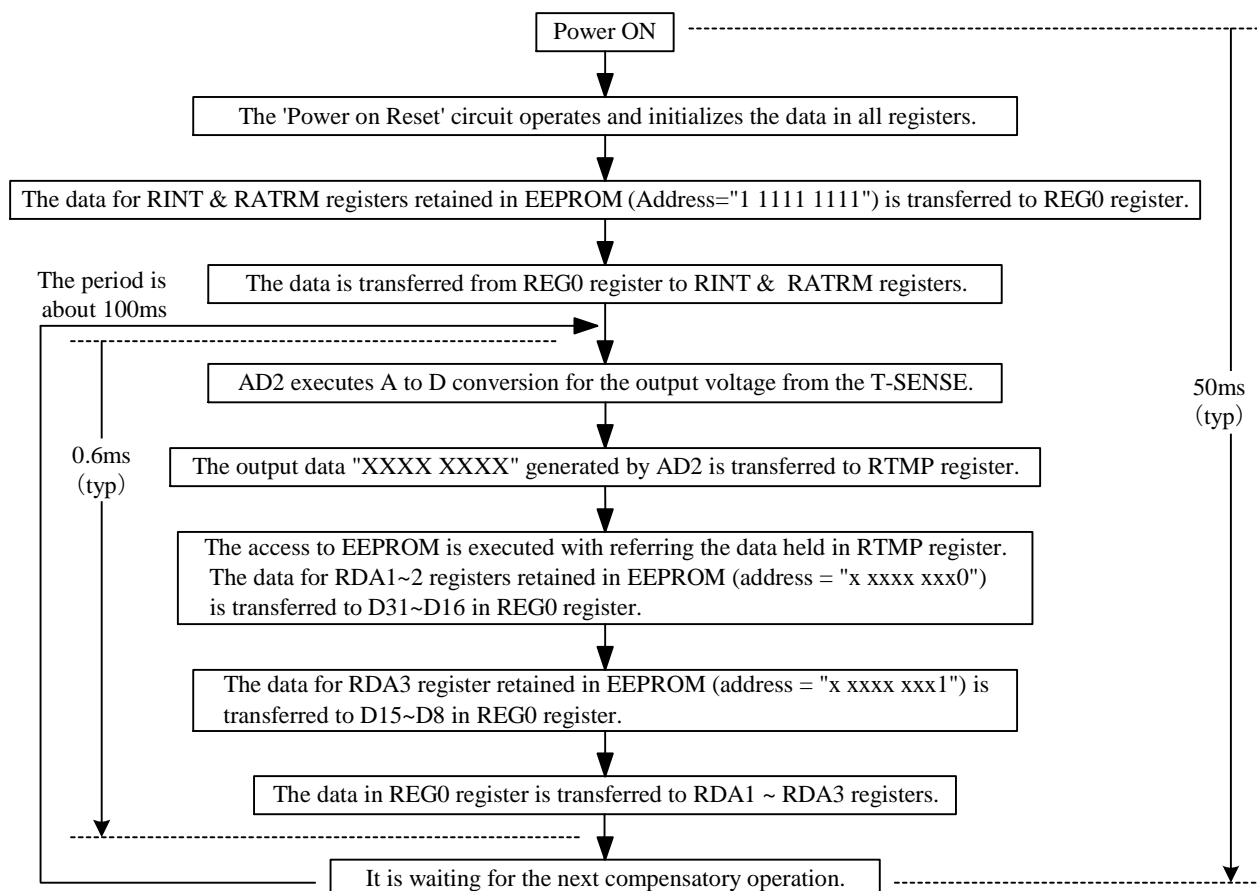

Note) REG0 register : This register synthesizes the 32bits data and temporarily holds the data when transferring the data from the EEPROM to the registers.

(2) Training mode

“Training mode” is used for the evaluation and the adjustment about AK2570. It is possible to write and read the data in the EERPOM and the registers and to execute activating the internal circuit for setting the temperature compensation data with the serial interface. Notice that it is possible to shift to “Training mode” by executing ‘Command for Training mode’ and any other command is not available while operating in “Self-operation mode”.

After executing ‘Command for Training mode’, it is necessary to input the clock or the ‘H’ level signal to SK-pin continuously to keep the operational mode is in “Training mode“. It is able to return to “Self-operational mode” by forcing the ‘L’ level signal to SK-pin for 50msec more in “Training mode”.

In “Training mode”, the periodical operation of temperature compensation for the LD is stopped. Also at the time of executing ‘Command for Training mode’ while operating in “Self-operational mode”, AK2570 transfers to “Training mode” after completing the periodical operation.

Recommended sequence in ”Training mode

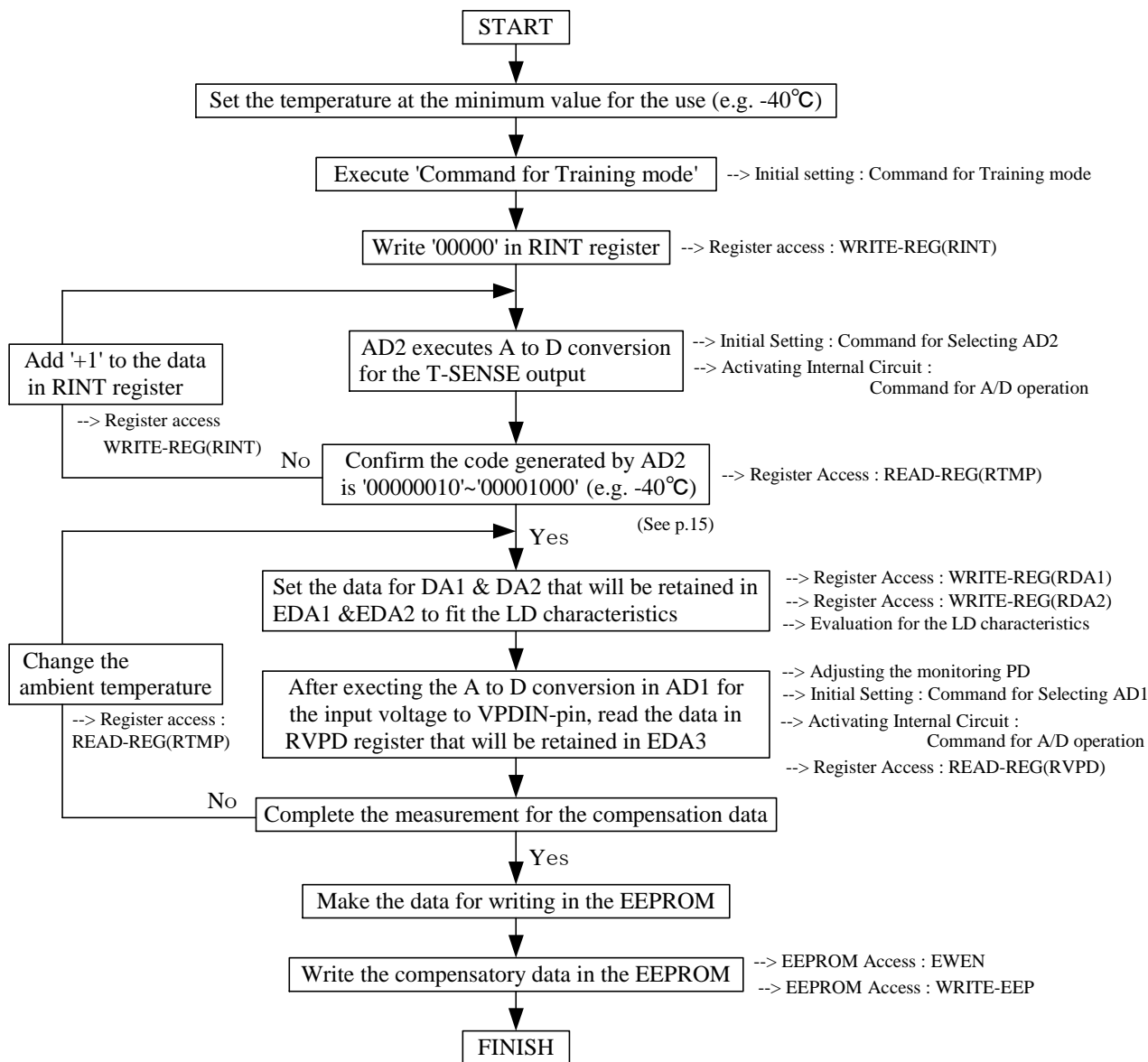

I) Initial Setting

[1] Command for Self-operation mode

By executing 'Command for Self-operation mode', it is possible to transfer the mode from "Training mode" to "Self-operation mode".

[2] Command for Training mode

By executing 'Command for Training mode', it is possible to transfer the mode from "Self-operation mode" to "Training mode". Also any command except 'Command for Training mode' is not available while AK2570 operates in "Self-operation mode".

[3] Command for Selecting AD1

'Command for selecting AD1' is available in "Training mode". This command sets that AD1 (the A to D converter for the input voltage to VPDIN-pin) is enable for the operation and the selector between AD1 and RVPD register is available. After this command is performed, the 8bits digital data of the VPDIN-pin signal encoded in AD1 is stored in RVPD register by executing 'Activating internal circuit - Command for A/D operation'.

[4] Command for Selecting AD2

'Command for selecting AD2' is available in "Training mode". This command sets that AD2 (the A to D converter for the output voltage from T-SENSE) is enable for the operation and the selector between AD2 and RTMP register is available. After this command is performed, the 8bits digital data of the T-SENSE output encoded in AD2 is stored in RTMP register by executing 'Activating internal circuit - Command for A/D operation'.

II) Activating internal circuit

[1] Command for A/D operation

'Command for A/D operation' makes that the selected A to D converter (AD1 or AD2) operates and the selected register (RVPD register or RTMP register) stores the data generated in the A to D converter selected by executing 'Command for Selecting AD1' or 'Command for Selecting AD2'. Also this command makes only that the selected register stores the 8bits digital data generated by the selected A to D converter.

[2] Command for Resetting data in RDA1-3

'Command for Resetting data in RDA1-3' sets that RDA1 ~ RDA3 registers hold the data retained in EEPROM which address is nominated by the data in RTMP register. Also this command is always available in "Training mode" and independent with the selector set by 'Command for Selecting AD1' or 'Command for Selecting AD2'.

III) Register Access

[1] Command for reading the data in the register (READ-REG)

It is able to read the data held in the nominated register by executing 'READ-REG' command.

[2] Command for Writing the data in the register (WRITE-REG)

It is able to write the data in the nominated register by executing 'WRITE-REG' command.

Register map

Name	Address	Data										Function	
		D23	~	D8	D7	D6	D5	D4	D3	D2	D1		D0
RTMP	000	X	~	X	D7	D6	D5	D4	D3	D2	D1	D0	Holding the data (temperature) generated by AD2
RDA1	001	X	~	X	D7	D6	D5	D4	D3	D2	D1	D0	Holding the data for DA1
RDA2	010	X	~	X	D7	D6	D5	D4	D3	D2	D1	D0	Holding the data for DA2
RDA3	011	X	~	X	D7	D6	D5	D4	D3	D2	D1	D0	Holding the data for DA3
RINT	100	X	~	X	X	X	X	D4	D3	D2	D1	D0	Holding the trimming data for T-SENSE [*1]
RVPD	101	X	~	X	D7	D6	D5	D4	D3	D2	D1	D0	Holding the data (VPDIN) generated by AD1
RATRM	110	X	~	X	X	X	X	D4	D3	D2	D1	D0	Holding the trimming data for ALMOUT [*2]

[*1] RINT register stores the initial data for the offset voltage of the T-SENSE

[*2] ATRM register stores the adjustment data for the alarm timing at the 50Mbps and the 156Mbps burst transmission (AKM recommends to use the EEPROM data for RATRM register already written at the shipment.)

Initial register data

Name	Address	D23	~	D8	D7	D6	D5	D4	D3	D2	D1	D0
RTMP	000	X	~	X	1	1	1	1	1	1	1	1
RDA1	001	X	~	X	0	0	0	0	0	0	0	0
RDA2	010	X	~	X	0	0	0	0	0	0	0	0
RDA3	011	X	~	X	0	0	0	0	0	0	0	0
RINT	100	X	~	X	X	X	X	0	0	0	0	0
RVPD	101	X	~	X	0	0	0	0	0	0	0	0
RATRM	110	X	~	X	X	X	X	1	0	0	0	0

<Note> 'X' is indefinite, '1' or '0'.

IV) EEPROM Access

[1] Command for enabling to write the data in the EEPROM (EWEN)

'EWEN' command makes it possible to write the data in the EEPROM. It is necessary to execute this command before writing the data in the EEPROM, because it is automatically set at 'Power ON' to prohibit writing the data in the EEPROM. In "Training mode", it is always possible to write the data in the EEPROM after executing this command except the case of 'Power OFF' or executing 'EWDS' command.

[2] Command for prohibiting to write the data in the EEPROM (EWDS)

'EWDS' command makes it impossible to write the data in the EEPROM and it is the same setting at 'Power ON'. This command is available to change the setting to prohibit writing the data in the EEPROM without 'Power OFF'.

[3] Command for writing the data in the EEPROM (WRITE-EEP)

It is able to write the data in the nominated EEPROM by executing 'WRITE-EEP' command. And it is necessary to execute 'EWEN' command at first for permitting to write the data in the EEPROM.

[4] Command for reading the data in the EEPROM (READ-EEP)

It is able to read the data held in the nominated EEPROM by executing 'READ-EEP' command.

EEPROM map

Name	Address			Data															
	A8	A7	A0	D15	D14	D13	D12	D11	D10	D9	D8	D7	D6	D5	D4	D3	D2	D1	D0
EDA12	0	0000	0000	The data for RDA1 (8bit)								The data for RDA2 (8bit)							
EDA3	0	0000	0001	The data for RDA3 (8bit)								The unused bits (8bit)							
EDA12	0	0000	0010	The data for RDA1 (8bit)								The data for RDA2 (8bit)							
EDA3	0	0000	0011	The data for RDA3 (8bit)								The unused bits (8bit)							
EDA12	1	1111	1100	The data for RDA1 (8bit)								The data for RDA2 (8bit)							
EDA3	1	1111	1101	The data for RDA3 (8bit)								The unused bits (8bit)							
ERES	1	1111	1110	The reserved bits (16bit)															
EINT	1	1111	1111	The unused bits (3bit)				The data for RATTRM (D12 - D8)(5bit)					The unused bits (3bit)			The data for RINT (D4 - D0)(5bit)			

<Note> AKM cannot assure the period of the data retention (10years [min.] at 85°C) for ‘The unused bits’.

<Note> Kindly pay attention when writing the data for RINT, because EINT also retains the data for RATTRM register written at AKM.

2 Serial Interface

In “Training mode”, it is able to execute the access to the EEPROM and the registers and to input the operational command for AK2570 with the 32bits serial data via 4pins consist of CS(#12), SK(#13), DI(#14) and DO(#15).

1) Constitution of the serial interface data

[a] “Initial setting”, “Activating Internal Circuit” and “Register Access” (total 32bits)

Classification	Selection	Address	Data
4bits	1bit	3bits	24bits

[b] “EEPROM Access” (Total 32bits)

Classification	Command	Address	Data
4bits	2bits	10bits	16bits

<Note> These bits contain the arbitrary bit (the data is not definite, ‘0’ or ‘1’).

Please refer to the table in the next page.

ASAHI KASEI

ii) Access to the serial interface

Classification	Select	Address	Data																						
1 1 0 0 [1]Initial Setting	1	0 0 0	x	x	x	x	x	x	x	x	x	x	x	x	x	x	x	x	x	x	x	x	x	x	
	1	0 0 1	x	x	x	x	x	x	x	x	x	x	x	x	x	x	x	x	x	x	x	x	x	x	
	1	0 1 0	x	x	x	x	x	x	x	x	x	x	x	x	x	x	x	x	x	x	x	x	x	x	
	1	0 1 1	x	x	x	x	x	x	x	x	x	x	x	x	x	x	x	x	x	x	x	x	x	x	
1 1 1 1 [2]Activating Internal Circuit	1	0 0 0	x	x	x	x	x	x	x	x	x	x	x	x	x	x	x	x	x	x	x	x	x	x	
	1	0 0 1	x	x	x	x	x	x	x	x	x	x	x	x	x	x	x	x	x	x	x	x	x	x	
1 1 1 0 [3]Register Access	0	0 0 0	x	x	x	x	x	x	x	x	x	x	x	x	x	x	x	x	x	x	D7	D6	D5	D4	D3
	0	0 0 1	x	x	x	x	x	x	x	x	x	x	x	x	x	x	x	x	x	x	D7	D6	D5	D4	D3
	0	0 1 0	x	x	x	x	x	x	x	x	x	x	x	x	x	x	x	x	x	x	D7	D6	D5	D4	D3
	0	0 1 1	x	x	x	x	x	x	x	x	x	x	x	x	x	x	x	x	x	x	D7	D6	D5	D4	D3
	0	1 0 0	x	x	x	x	x	x	x	x	x	x	x	x	x	x	x	x	x	x	x	x	D4	D3	
	0	1 0 1	x	x	x	x	x	x	x	x	x	x	x	x	x	x	x	x	x	x	D7	D6	D5	D4	D3
	0	1 1 0	x	x	x	x	x	x	x	x	x	x	x	x	x	x	x	x	x	x	x	x	D4	D3	
	1	0 0 0	x	x	x	x	x	x	x	x	x	x	x	x	x	x	x	x	x	x	D7	D6	D5	D4	D3
	1	0 0 1	x	x	x	x	x	x	x	x	x	x	x	x	x	x	x	x	x	x	D7	D6	D5	D4	D3
	1	0 1 0	x	x	x	x	x	x	x	x	x	x	x	x	x	x	x	x	x	x	D7	D6	D5	D4	D3
	1	0 1 1	x	x	x	x	x	x	x	x	x	x	x	x	x	x	x	x	x	x	D7	D6	D5	D4	D3
	1	1 0 0	x	x	x	x	x	x	x	x	x	x	x	x	x	x	x	x	x	x	x	x	D4	D3	
	1	1 0 1	x	x	x	x	x	x	x	x	x	x	x	x	x	x	x	x	x	x	D7	D6	D5	D4	D3
1	1 1 0	x	x	x	x	x	x	x	x	x	x	x	x	x	x	x	x	x	x	D7	D6	D5	D4	D3	
1 1 0 1 [4]EEPROM Access	0	0 0 0	0	0	x	x	x	x	x	x	x	x	x	x	x	x	x	x	x	x	x	x	x	x	
	0	0 1 1	1	x	x	x	x	x	x	x	x	x	x	x	x	x	x	x	x	x	x	x	x	x	
	0	1 x	A8	A7	A6	A5	A4	A3	A2	A1	A0	D15	D14	D13	D12	D11	D10	D9	D8	D7	D6	D5	D4	D3	
	1	0 x	A8	A7	A6	A5	A4	A3	A2	A1	A0	D15	D14	D13	D12	D11	D10	D9	D8	D7	D6	D5	D4	D3	
Classification	Command	Address									Data														

Note) 'x' in this table is not definite, '0' or '1'.

III) Timing for the serial interface

[1] Initial Setting

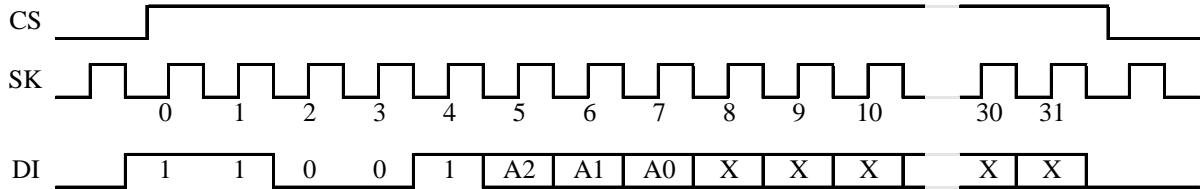

A2	A1	A0	
0	0	0	--- Command for Self-operation mode
0	0	1	--- Command for Training mode
0	1	0	--- Command for Selecting AD2
0	1	1	--- Command for Selecting AD1

[2] Activating Internal Circuit

[a] Command for A/D operation

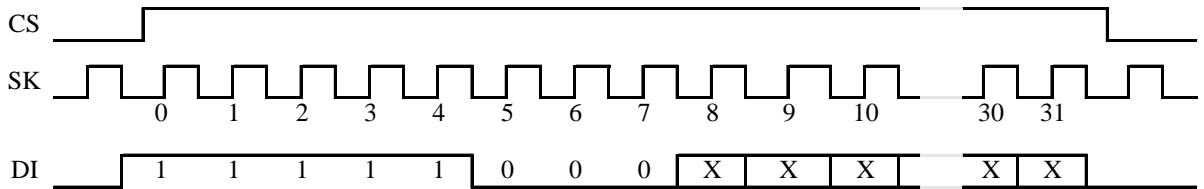

[b] Command for Resetting data in RDA1-3

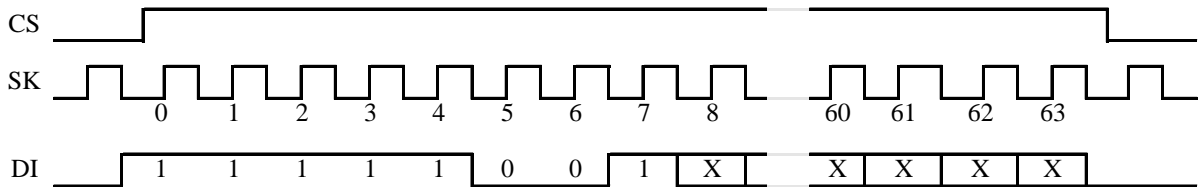

<Note> In the case of executing 'Command for Resetting data in RDA1-3', it is necessary to input the 64 clocks to SK-pin with keeping to force the 'H' level signal to CS-pin.

[3] Register Access

[a] Command for reading the data in register(READ-REG)

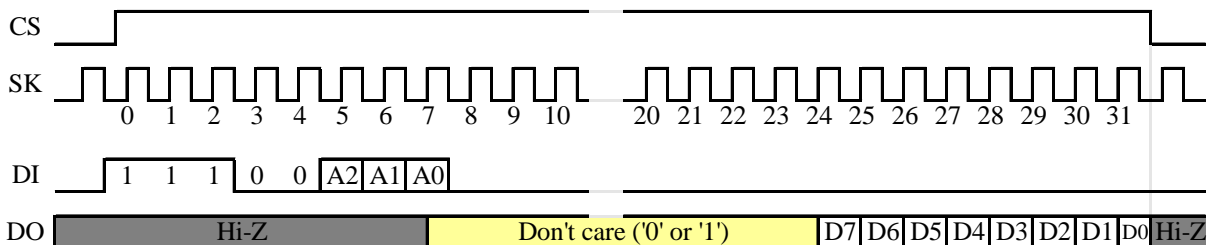

[b] Command for writing the data in the register (WRITE-REG)

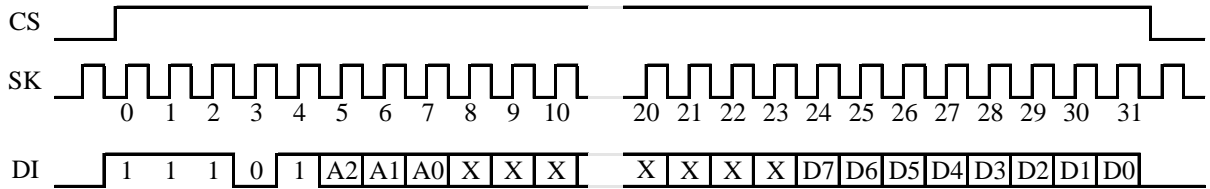

A2	A1	A0	Register	Data
0	0	0	RTMP =	8bits
0	0	1	RDA1 =	8bits
0	1	0	RDA2 =	8bits
0	1	1	RDA3 =	8bits
1	0	0	RINT =	5bits
1	0	1	RVPD =	8bits
1	1	0	RATRM =	5bits

[4] EEPROM Access

[a] Command for enabling/prohibiting to write the data in the EEPROM (EWEN/EWDS)

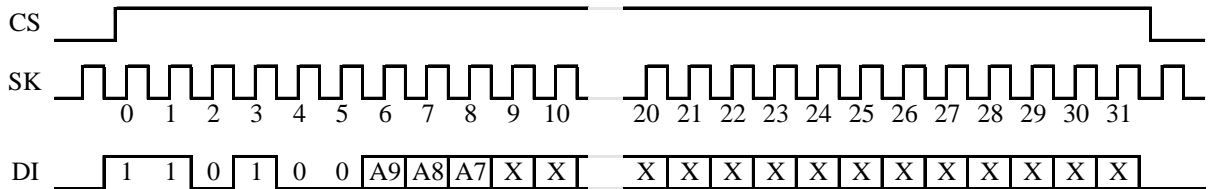

A9	A8	A7	Command
0	0	0	EWDS command
1	1	1	EWEN command

[b] Command for writing the data in the EEPROM (WRITE-EEP)

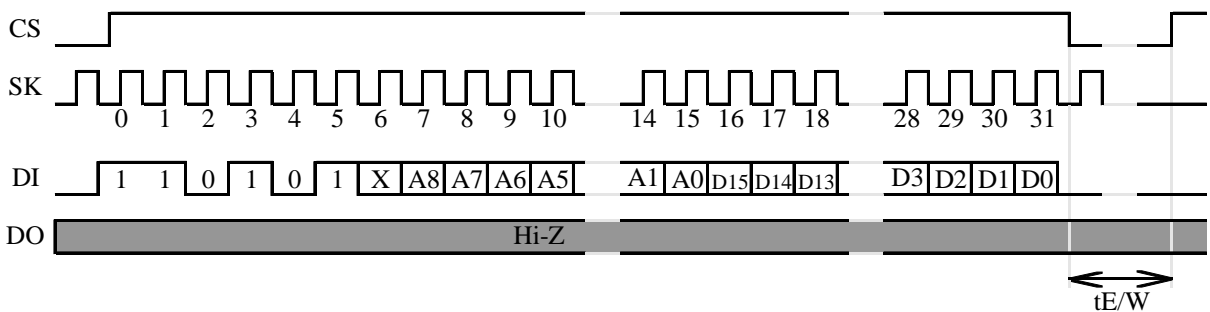

[c] Command for reading the data in the EEPROM (READ-EEP)

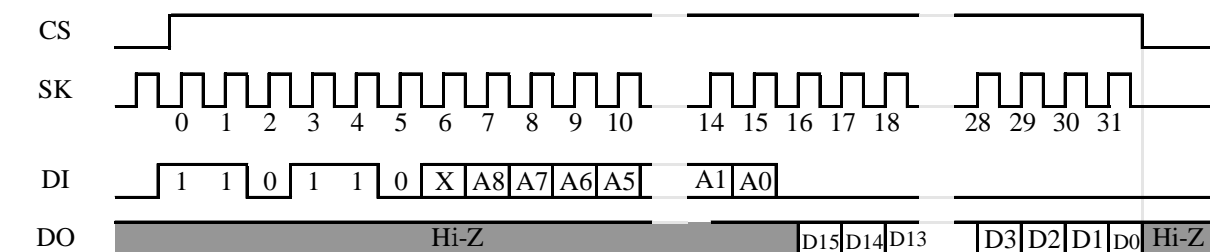

3. Thermo-sensor (T-SENSE)

Kindly see the figure below that shows the relationship between the detected ambient temperature (T) and the generated output voltage (VT) in the T-SENSE.

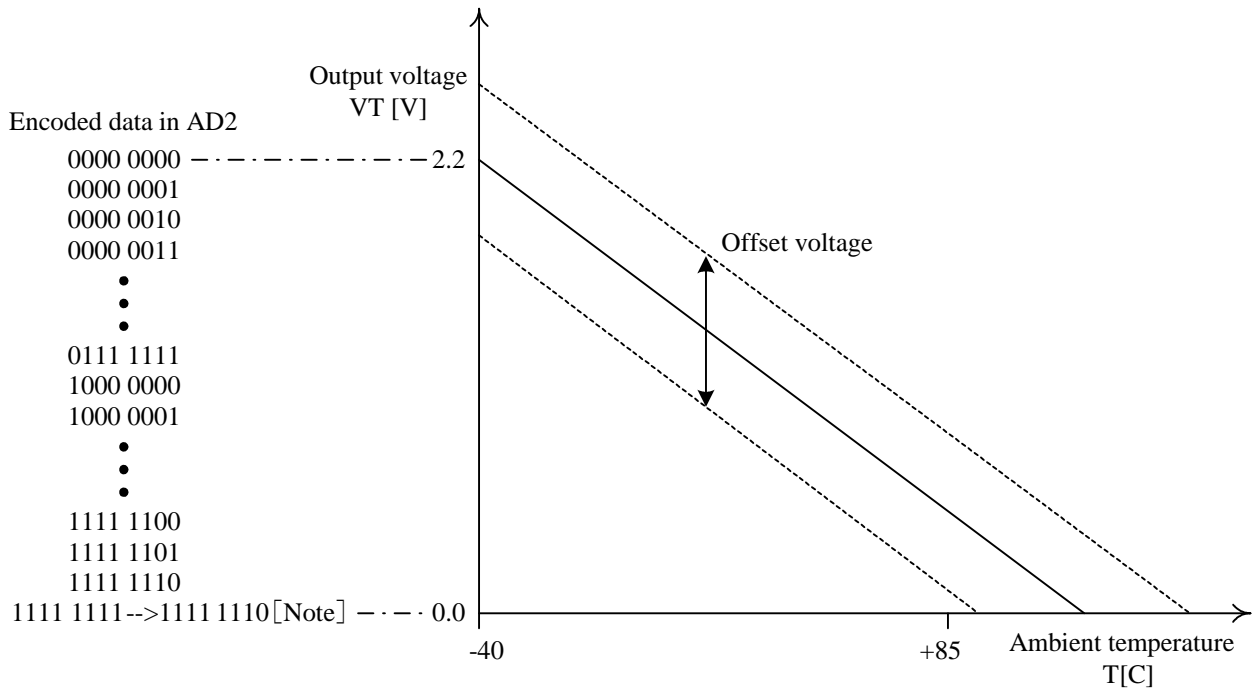

[Note] In 'Self-operation mode', it is the unique case that the data "1111 1111" generated by AD2 is converted to "1111 1110" automatically and the EEPROM data in the address '1 1111 110X' is used as the compensation data, this is the reason why that the EEPROM which address is "1 1111 111X" retains the reserved data and the trimming data for the T-SENSE and the ALMOUT.

VT is 2.2V (Typ.) at -40°C and 0.0V at 85°C above and has the distribution due to each LSI. However it is possible to cancel the distributed offset voltage arising in the T-SENSE among LSIs by setting the data (D4 ~D0) in RINT register. The offset cancel voltage (Reference) corresponding to the data (D4 ~D0) in RINT register is shown in the table below.

RINT register					Offset cancel voltage [mV] (Reference)
D4	D3	D2	D1	D0	
1	1	1	1	1	+375
1	1	1	1	0	+350
1	1	1	0	1	+325
1	1	1	0	0	+300
1	0	0	0	1	+25
1	0	0	0	0	0
0	1	1	1	1	-25
0	0	0	1	1	-325
0	0	0	1	0	-350
0	0	0	0	1	-375
0	0	0	0	0	-400

*Set up for the RINT register

The offset voltage arising in the T-SENSE is slightly different and has the distribution among the LSIs.

Please adjust that the data in RTMP register exists between the 'Minimum code' and the 'Maximum code' shown in this table at the 'Minimum ambient temperature for the use' with writing the data in RINT register in "Training mode", and refer to 'Recommended sequence in "Training mode"' in p.7.

Minimum ambient temperature for the use	Minimum code	Maximum code
0°C	01000010	01001000
-20°C	00100010	00101000
-30°C	00010010	00011000
-40°C	00000010	00001000
In the case of fitting at +25°C(Reference)	01100110	01101100

<Reference>

1LSB of AD2 output data (8bits) is 8.63mV (Typ.). Therefore 6codes is 51.8mV (Typ.) corresponding to the range between 'Minimum code' and 'Maximum code' shown in above table. On the other hand, the step of the offset cancel voltage is 25mV (Typ.) and it is possible to adjust the output voltage of the T-SNESE in the range of 'Minimum code' and 'Maximum code'.

After this offset voltage adjustment, the output voltage from the T-SENSE becomes appropriate for the AD2 input range at every ambient temperature (-40°C ~ +85°C). Also the 'Minimum code' and the 'Maximum code' for this adjustment increase 16 codes/10°C.

4. D to A converter (DA1 and DA2)

In the normal operation, forcing the 'L' level signal to SHUTDN-pin makes that DAOUT1 (the output of DA1 +AMP1) and DAOUT2 (the output of DA2+AMP2) output the voltage corresponding to the data in RDA1 and RDA2 registers.

On the other hand, forcing the 'H' level signal to SHUTDN-pin makes that DAOUT1 and DAOUT2 output 0V (Min.). Also the data in RDA1 and RDA2 registers does not change and is held while forcing 'Shut down signal (the 'H' level)'. By forcing the 'L' level signal to SHUTDN-pin again, DAOUT1 and DAOUT2 output the signal corresponding the continuously held data in RDA1 and RDA2 registers.

5. Alarm circuit (DA3, ALMOUT, Comparator and ALM Timing Generator)

D) Mode setting

The alarm circuit has the 3 modes (the Continuous mode, the 156Mbps burst transmission mode and the 50Mbps burst transmission mode). Each mode is set by the signals forced to ALMMOD0-pin and ALMMOD1-pin.

ALMMOD1	ALMMOD0	Mode
0	0	the Continuous mode
0	1	the 50Mbps burst transmission mode
1	0	the 156Mbps burst transmission mode
1	1	Prohibited

II) Continuous mode

The alarm circuit compares the input voltage to VPDIN-pin (the monitoring PD signal) and the output voltage from DA3 (the alarm threshold level). The data for the alarm threshold level is retained in the EEPROM (EDA3), transferred to RDA3 and converted D to A signal in DA3. At any time, the 'H' level alarm signal can be generated and outputted from ALM-pin in the case that the input voltage to VPDIN-pin becomes lower than the output voltage of DA3.

III) 50Mbps burst transmission mode and 156Mbps burst transmission mode

The alarm circuit compares the input voltage to VPDIN-pin (the monitoring PD signal) and the output voltage from DA3 (the alarm threshold level). The data for the alarm threshold level is retained in the EEPROM (EDA3), transferred to RDA3 and converted D to A signal in DA3.

The alarm circuit detects the polarity of the input signal to ENVIN-pin at the constant timing (the detecting point) from the rising edge ('L' to 'H') of this signal. The alarm circuit outputs the alarm signal (the 'H' level) from ALM-pin in the case that the input voltage to VPDIN-pin is lower than the output voltage from DA3 and ENVIN signal is still kept at the 'H' level. Also the alarm circuit detects the rising edge of the ENVIN signal and fixes the constant timing to output the alarm signal.

In the case that VPDIN signal recovers and becomes higher than the alarm threshold level at the detecting point with ENVIN = 'H' or that the ENVIN signal becomes the 'L' level, the alarm circuit outputs the 'L' level (the normal signal) from ALM-pin.

* In the case of outputting the alarm signal continuously

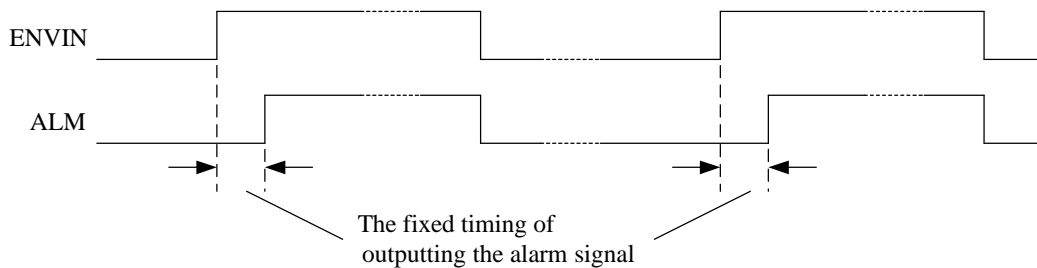

* In the case of stopping the alarm signal (the VPDIN signal recovers)

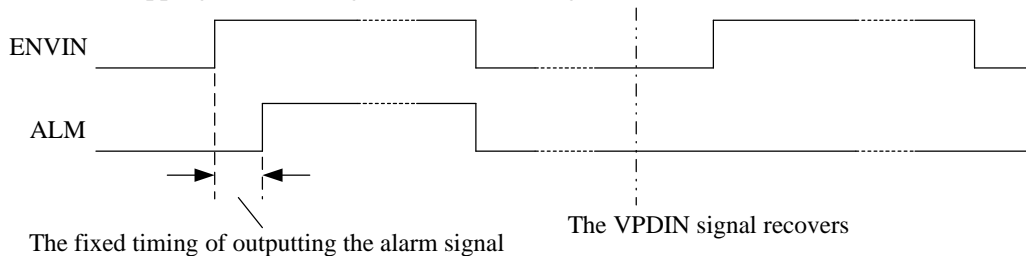

ABSOLUTE MAXIMUM RATING

Parameter	Symbol	Min.	Max.	Unit	Remark
Power supply voltage	VDD	-0.3	6.0	V	DVDD-pin, AVDD-pin
Ground level	VSS	0.0	0.0	V	DVSS-pin, AVSS-pin
Digital input voltage	VDIN	-0.3	VDD+0.3	V	
Analog input voltage	VAIN	-0.3	VDD+0.3	V	
Input current	IIN	-10	10	mA	Except the pins above
Storage temperature	TSTG	-55	+125	°C	

<Note> AK2570 may operate abnormally and be broken under the condition exceeding the range shown above.

RECOMMENDED OPERATING CONDITION
--

AKM can assure the characteristics of AK2570 specified in this data sheet under the condition as below.

Parameter	Symbol	Min.	Typ.	Max.	Unit	Remark
Power supply voltage	VDD	2.97	3.30	3.63	V	
	VSS	0.0	0.0	0.0	V	
Ambient temperature for operation	Ta	-40		85	°C	

ELECTRICAL CHARACTERISTICS

(1) Power Consumption

Parameter	Symbol	Min.	Typ.	Max.	Unit	Remark
Consumptive current	IDD			30	mA	

<Note> The consumptive current which does not include the driving current for the outputs is measured under the condition that the digital input pins are connected to VSS or VDD.

(2) EEPROM characteristics

Parameter	Min.	Typ.	Max.	Unit	Remark
EEPROM total writing times	10000			time	
EEPROM data retention 1	10			year	85°C
EEPROM data retention 2	300			year	50°C (Reference)

(3) Digital Part

[a] DC characteristics

Parameter	Symbol	Condition	Min.	Typ.	Max.	Unit
Input higher voltage	VIH		0.7VDD		VDD	V
Input lower voltage	VIL		VSS		0.3VDD	V
Input higher current	IIH	VIH = VDD			10	μA
Input lower current	IIL	VIL = 0V	-10			μA
Output higher voltage	VOH	IOH = -0.2mA	0.9VDD			V
Output lower voltage	VOL	IOL = 0.2mA			0.1VDD	V

[b] AC characteristics

Parameter	Symbol	Condition	Min.	Typ.	Max.	Unit
SK : Period	tSKP	While A/D conversion	10			μs
	tSKP	While other operation	2			μs
SK : Pulse duty	tSKW		40		60	%
Delay time : CS='H' to SK='H'[*]	tCSS		150			ns
Delay time : SK='L' to CS='L'	tCSH		0			ns
Time for setting up the data	tDIS		200			ns
Time for holding the data	tDIH		200			ns
Delay time for the output	tPD	CL = 100pF			1	μs
Time to write in the EEPROM	tE/W		10			ms
CS : Minimum time in the 'L' level	tCS		250			ns
Delay time : CS='L' to DO='Hi-Z'	tOZ				100	ns

[*] It is necessary to force the 'L' level to SK-pin at the rising edge of the CS signal and to apply the clock to SK-pin at 150msec or more after this rising edge of the CS signal.

Digital Part – AC characteristics : Timing

[1] Timing for the command input

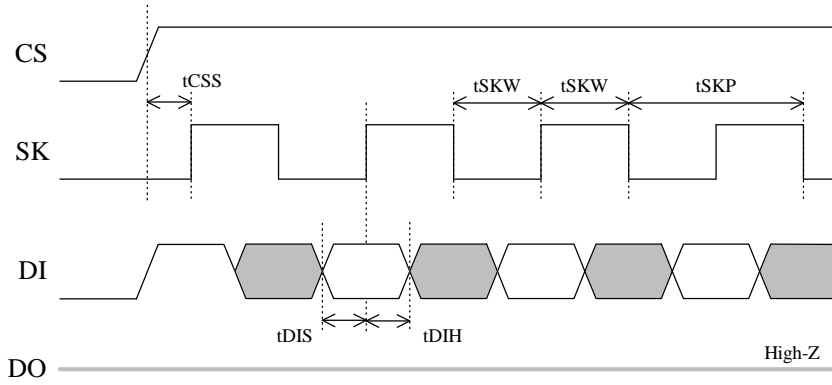

[2] Timing for the data output

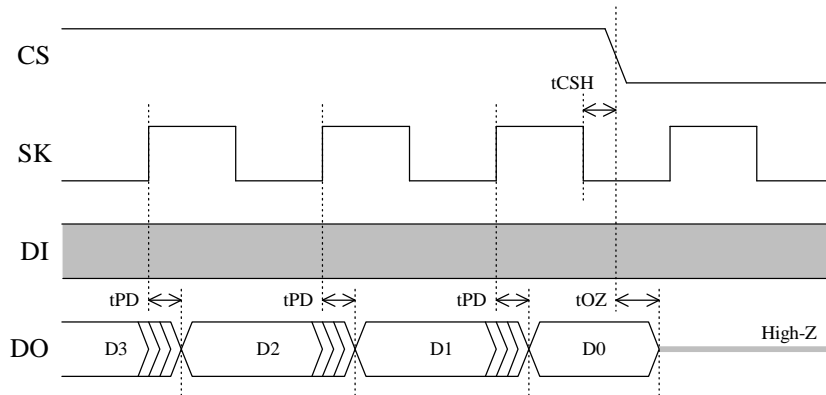

[3] Timing for writing the data in the EEPROM

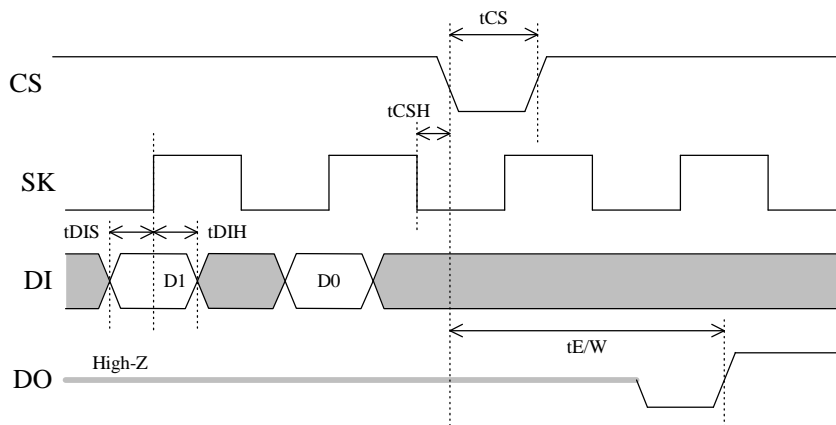

(4) Analog part

[a] Input characteristics of the A to D converter

<1> AD1

Resolution	8bits linear								
Conversion time	About 150μs or 15 SK clocks								
DNL	± 2LSB								
Input range 1 (Peak voltage)	0.0V ~ 1.0V [Typ]								
	MSB							LSB	Input voltage
	D7	D6	D5	D4	D3	D2	D1	D0	
	1	1	1	1	1	1	1	1	à 1.0V
	1	1	1	1	1	1	1	0	
	(Straight binary)								
	0	0	0	0	0	0	0	1	
	0	0	0	0	0	0	0	0	à 0.0V

<2> AD2

Resolution	8bits linear								
Conversion time	About 150μs or 15 SK clocks								
DNL	± 0.7LSB								
Input range 2 (Temperature)	0.0V ~ 2.2V [Typ.]								
	MSB							LSB	Input voltage
	D7	D6	D5	D4	D3	D2	D1	D0	(Detected temperature)
	0	0	0	0	0	0	0	0	à 2.2V (-40°C)
	0	0	0	0	0	0	0	1	
	(Straight binary)								
	1	1	1	1	1	1	0	1	
	1	1	1	1	1	1	1	0	à 0.0V (> 85°C)

[b] Output characteristics of the A to D converter

<1> DA1, DA2

Parameter	Min.	Typ.	Max.	Unit	Remark
Resolution		8		bit	Circuit design
DNL	-1/2		+1/2	LSB	
Maximum output voltage	0.425	0.500	0.575	V	±15% <Note>
Minimum output voltage	0.0		10.0	mV	
Output voltage at the shut down operation	0.000		5.000	mV	SHUTDOWN-pin is forced 'H'
Output current	2.50			mA	Input code =181 (dec)

<Note> ±5% included in the range ±15% is the distribution caused by the fluctuations of the power source voltage and the ambient temperature.

<2> The over shoot voltage of DA1 and DA2 at relieving the shut down operation

Input data for DA1 and DA2	Min.	Typ.	Max.	Unit	Remark
11111111 11111110 00001001 00001000			‘Output voltage’×1.2	mV	Designed guarantee value
00000111 00000110 00000001 00000000			13.0 (Stabilized in 120μs)	mV	Designed guarantee value

<3> DA3

	Min.	Typ.	Max.	Unit	Remark
Resolution		8		bit	Circuit design
Voltage step by 1 code		3.92		mV	Designed guarantee value
Maximum output voltage		1.00		V	Designed guarantee value
Minimum output voltage		0.00		mV	Designed guarantee value

<4> Relationship between the input digital code and the output voltage

D to A converter	Digital code	Output voltage (Typ.)
DA1	11111111	500mV
	00000001	1.96mV
	00000000	0.0V
DA2	11111111	500mV
	00000001	1.96mV
	00000000	0.0V
DA3	11111111	1.0V
	00000001	3.92mV
	00000000	0.0V

[c] Output characteristics of the alarm signal

<1> Continuous mode

Parameter	Symbol	Condition	Min.	Typ.	Max.	units
Delay time of ALM signal	tDLY	DA3 output=0.5V VPDIN=2.0V±0V			100	ns

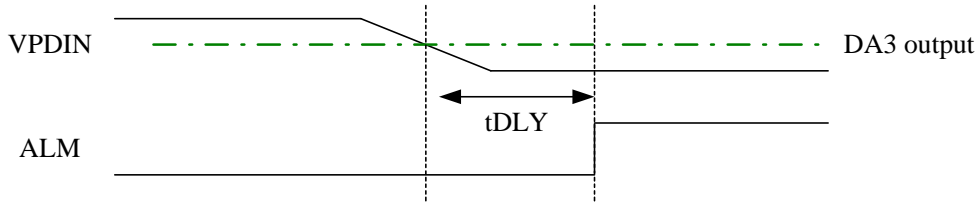

<2> 50Mbps burst transmission mode

Parameter	Symbol	Condition	Min.	Typ.	Max.	unit
Start time for detecting ENV signal	tENVDT1		463.0			ns
Total time for detecting ENV signal	tENVDT2				617.3	ns
Time for detecting ENV signal	tENVDT				154.3	ns
Time for confirming VPDIN signal	tVIN			212.2		ns
Time for outputting ALM signal	tALMO	CL=20pF	463.0		771.6	ns

[*] The condition of measuring for the ‘Time for outputting ALM signal’ is that the input voltage to VPDIN-pin is 0.0V (constant).

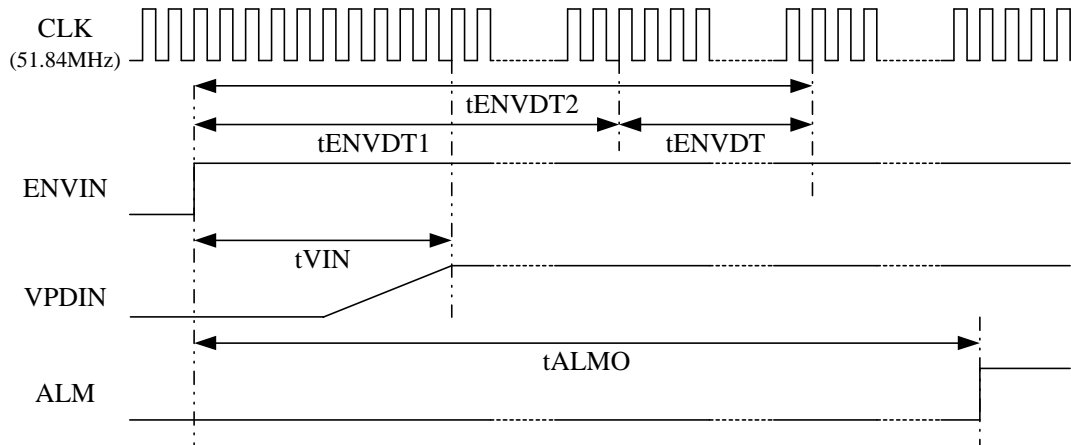

<Note> The clock (51.84MHz) is not applied to AK2570.

<3> 156Mbps burst transmission mode

Parameter	Symbol	Condition	Min.	Typ.	Max.	unit
Start time for detecting ENV signal	tENVDT1		167.2			ns
Total time for detecting ENV signal	tENVDT2				218.8	ns
Time for detecting ENV signal	tENVDT				51.4	ns
Time for confirming VPDIN signal	tVIN			64.3		ns
Time for outputting ALM signal	tALMO	CL=20pF	167.2		372.9	ns

[*]The condition of measuring for the ‘Time for outputting ALM signal’ is that the input voltage to

VPDIN-pin is 0.0V (constant).

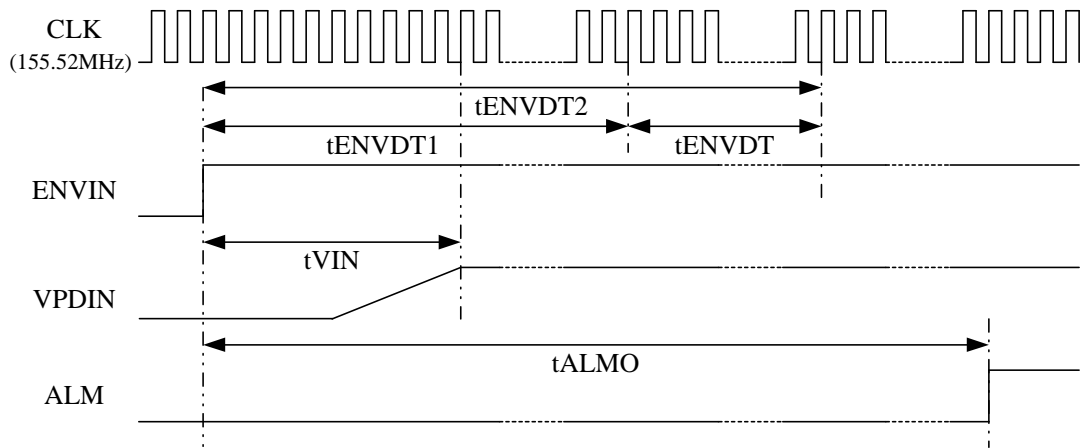

<Note> The clock (155.52MHz) is not applied to AK2570.

Delay time between the falling edge of ENVIN and that of ALM

In the 50Mbps burst transmission mode and the 156Mbps burst transmission mode, the ALM signal becomes the 'L' level in the case of that the ALM signal is still generated (at the 'H' level) and the 'L' level signal is forced to ENVIN-pin (ENV signal). There is the delay time between the falling edge of the ENV signal and that of the ALM signal in this case.

Parameter	Symbol	Condition	Min.	Typ.	Max.	unit
Delay time between the falling edge of ENVIN and that of ALM	tALMDL	CL=20pF			19.3	ns

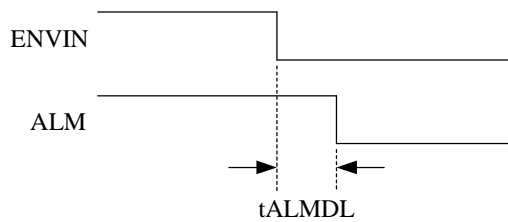

Error on the judgment for ALM signal

There is some error on the judgment for generating the alarm signal. Therefore ALM signal will be often generated in the case that the input voltage to VPDIN-pin is slightly bigger than the DA3 output (the alarm threshold level). The error shown below is the value against the DA3 output.

DA3 output (Typ.)	Error on the judgment for ALM signal [*]	Remarks
58.8mV	± 3dB	Designed reference value
98.0mV	± 2dB	Designed reference value

[*] dB = the converted value for the power

RECOMMENDED EXTERNAL CIRCUIT

[1] BIAS-pin for the reference voltage

Kindly connect the resistance (the $\pm 1\%$ accuracy) between BIAS-pin and AVSS with the line pattern as short as possible.

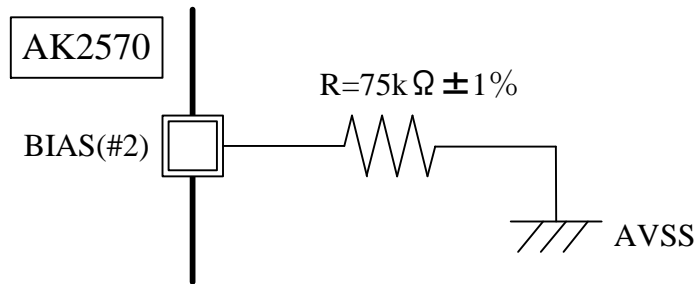

[2] Power pins

Kindly insert the capacitor as shown below between DVDD-DVSS and AVDD-AVSS.

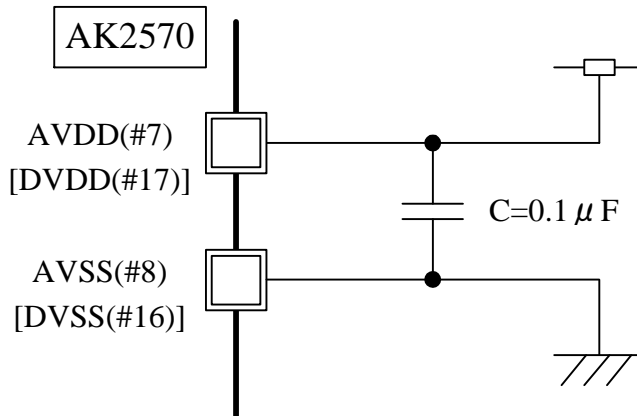

EXAMPLE for EXTERNAL CIRCUIT

[a] The examples of the external circuit for DAOUT1-pin / FB1-pin and DAOUT2-pin / FB2-pin are shown below in the case of the use at the direct variation for the LD.

<1> Example [1]

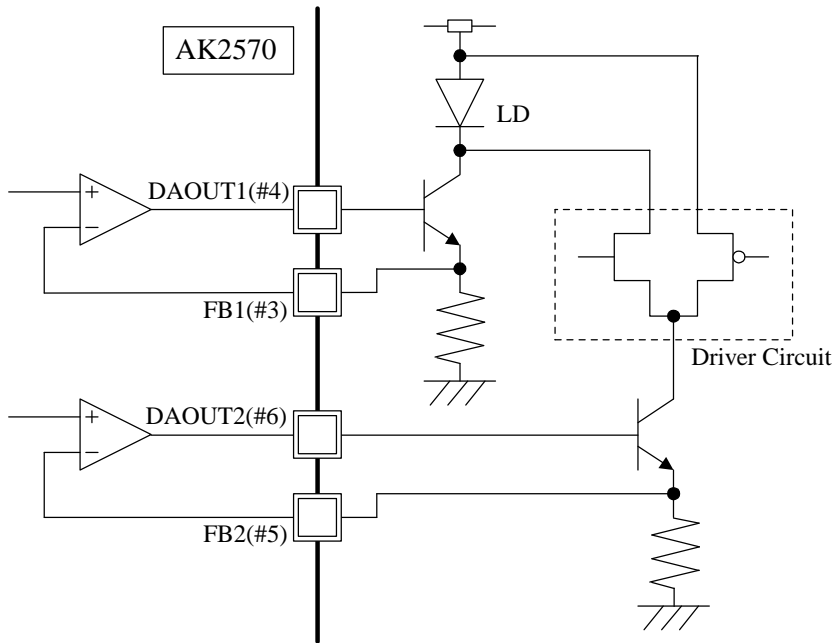

<2> Example [2]

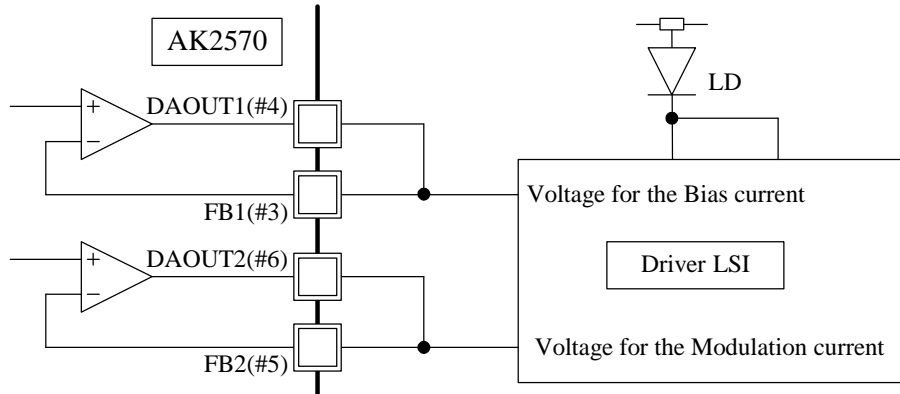

[b] The example of the external circuit for VPDIN-pin is shown below.

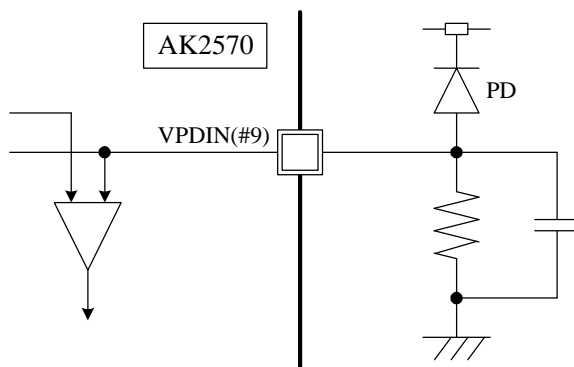

PACKAGE

Package type : 20pin - SSOP

Marking on the surface of the package :

- (1) Index : Indicating Pin #1
- (2) Company name : AKM
- (3) Product No. : AK2570
- (4) Date code : XXXXXXXX (7 figures)

Package size :

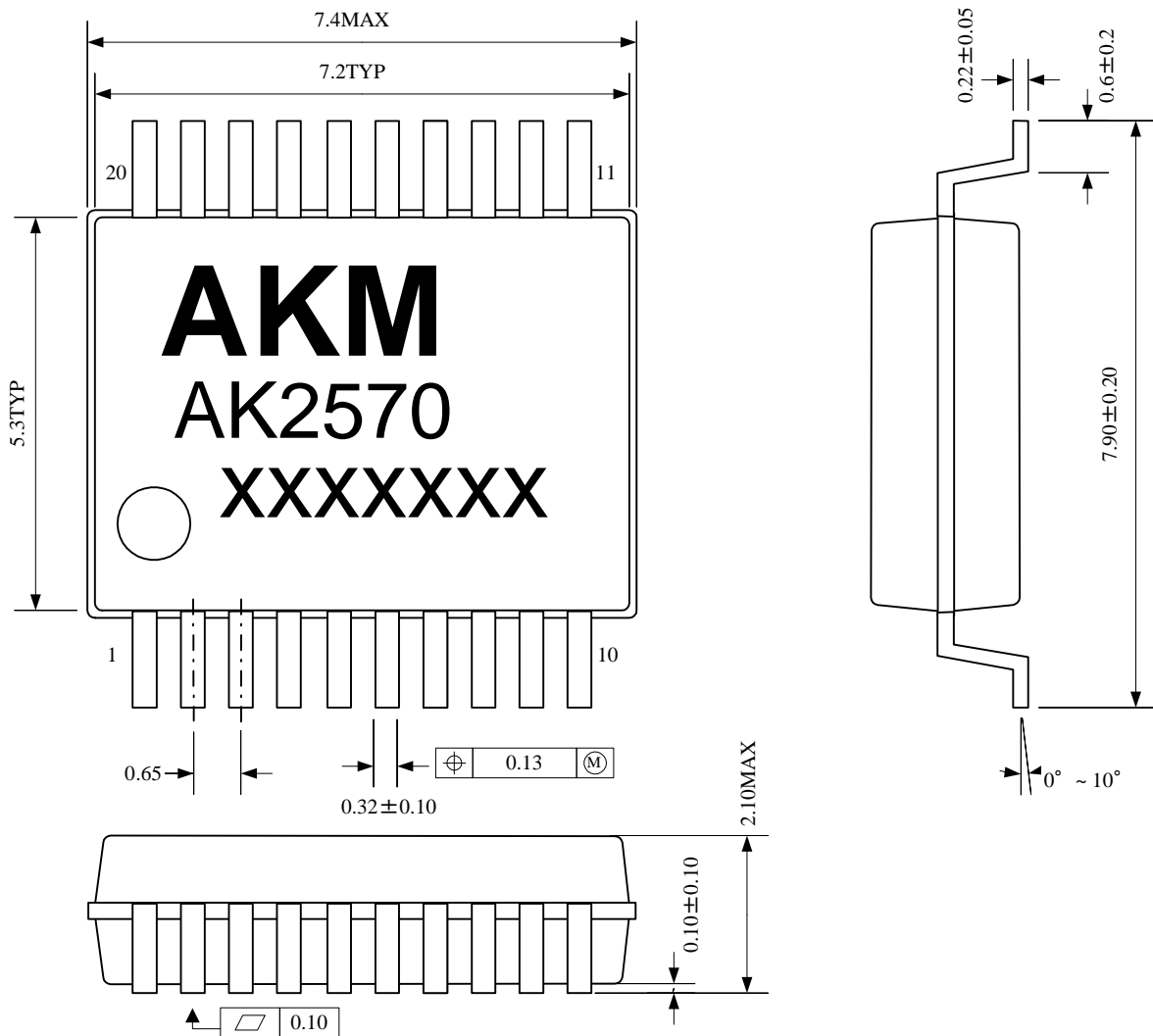

IMPORTANT NOTICE

- These products and their specifications are subject to change without notice.
Before considering any use or application, consult the Asahi Kasei Microsystems Co., Ltd. (AKM) sales office or authorized distributor concerning their current status.
- AKM assumes no liability for infringement of any patent, intellectual property, or other right in the application or use of any information contained herein.
- Any export of these products, or devices or systems containing them, may require an export license or other official approval under the law and regulations of the country of export pertaining to customs and tariffs, currency exchange, or strategic materials.
- AKM products are neither intended nor authorized for use as critical components in any safety, life support, or other hazard related device or system, and AKM assumes no responsibility relating to any such use, except with the express written consent of the Representative Director of AKM. As used here:
 - (a) A hazard related device or system is one designed or intended for life support or maintenance of safety or for applications in medicine, aerospace, nuclear energy, or other fields, in which its failure to function or perform may reasonably be expected to result in loss of life or in significant injury or damage to person or property.
 - (b) A critical component is one whose failure to function or perform may reasonably be expected to result, whether directly or indirectly, in the loss of the safety or effectiveness of the device or system containing it, and which must therefore meet very high standards of performance and reliability.
- It is the responsibility of the buyer or distributor of an AKM product who distributes, disposes of, or otherwise places the product with a third party to notify that party in advance of the above content and conditions, and the buyer or distributor agrees to assume any and all responsibility and liability for and hold AKM harmless from any and all claims arising from the use of said product in the absence of such notification.