

AKM

AK8817

NTSC/PAL Digital Video Encoder

General Description

The AK8817 is a Digital Video Encoder for Portable and Mobile application. ITU-R BT.601 level compatible Y, Cb, and Cr signals which correspond to 27MHz or square pixel are encoded into either NTSC or PAL compatible composite video signal. Interface is made in HSYNC-, VSYNC- synchronized slave-mode operation or ITU-R.Bt656. AK8817 has 75ohm driver with LPF.

It is possible to encode the VBI(CGMS-A) and WSS signal on the output video signal.
Host Control interface is I2C Bus I/F.

Features

- NTSC-M, PAL-B, D, G, H, I Composite Video encoding
- Y:Cb:Cr 4:2:2
- H/V Slave Operation / ITU-R.BT656 Interface
- Y filtering: 2 x over-sampling
- C filtering: 4 x over-sampling
- 9bit DAC
- Setup
- VBI (CGMS-A) Compatible
- WSS Compatible
- Operation Clock rate : 27MHz or Square-pixel Clock rate(NTSC:24.5454MHz/PAL29.50MHz)
- Video Amp with LPF
- On-chip Color Bar Output
- Black Burst Output
- Power Supply (AVDD, DVDD) 2.7V - 3.3V
- I/F Power Supply (PVDD) 1.6V - 3.3V
- Power Down mode
- Monolithic CMOS
- 41pin FBGA(4mm x 4mm) (Pb Free)

Block Diagram

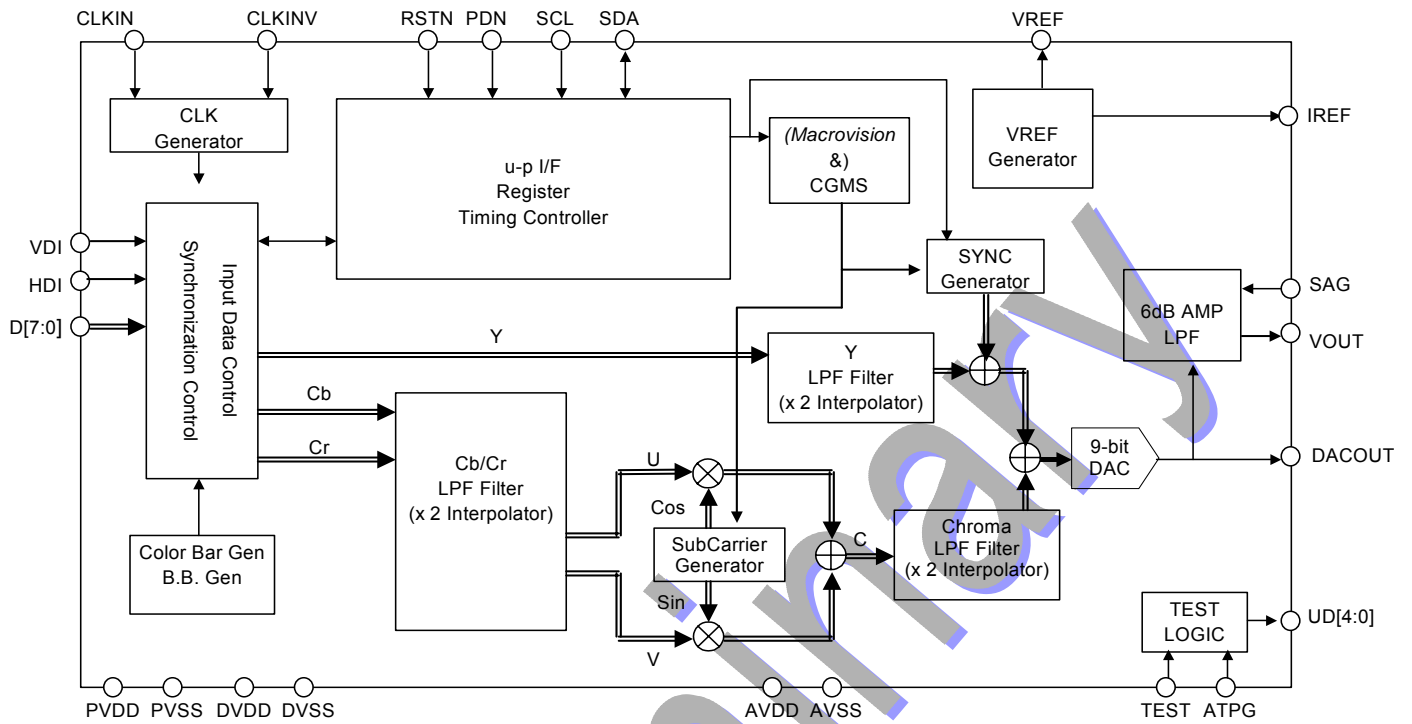

Ordering Guide

AK8817VG 41pin FBGA

Pin Assignment

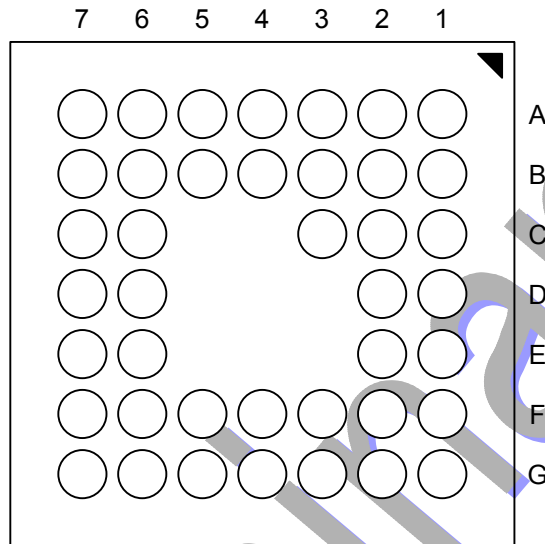

Bottom View

	1	2	3	4	5	6	7	
A	NC	DACOUT	SAG	VOUT	DVDD	RSTN	NC	
B	AVDD	AVSS	BVSS	DVSS	PDN	SCL	ATPG	
C	VREF	IREF	INDEX			HDI	SDA	
D	UD3	UD4				PVSS	VDI	
E	UD1	UD2					D0	PVDD
F	CLKINV	UD0	DVSS	D7	D5	D3	D1	
G	NC	CLKIN	DVDD	D6	D4	D2	TEST	

TOP View

Pin Functional Description

Pin#	Pin Name	I/O	Functional Outline
G2	CLKIN	I	Clock input pin. Input a clock which is synchronized with data. When to input 601 data : 27 MHz. When to input square pixel data : 24.5454 MHz (NTSC)/ 29.50 MHz (PAL)
F1	CLKINV	I	Internal clock is inverted (internal operation timing edge is inverted.) Connect to either DVDD or DGND.
B5	PDN	I	Power Down Pin. After returning from PD mode to normal operation, RESET Sequence should be done to AK8817. “L “(GND level): Power-down “H “: normal operation
A6	RSTN	I	Reset input pin. In order to initialize the device , an initialization must be made in accordance with the reset sequence. “L “ : reset “H “ : normal operation Hi-Z input is acceptable to this pin at PDN = L.
C7	SDA	I	I2C data pin. This pin is pulled-up to PVDD. Hi-Z input is possible when PDN is at low. SDA input is not accepted during the reset sequence operation.
B6	SCL	I	I2C clock input pin An input level of lower-than-PVDD should be input. Hi-Z input is possible when PDN is at low. SCL input is not accepted during the reset sequence operation.
F4	D7	I	Data Video Signal input pin (MSB). Hi-Z input is acceptable to this pin at PDN = L.
G4	D6	I	Data Video Signal input pin. Hi-Z input is acceptable to this pin at PDN = L.
F5	D5	I	Data Video Signal input pin. Hi-Z input is acceptable to this pin at PDN = L.
G5	D4	I	Data Video Signal input pin. Hi-Z input is acceptable to this pin at PDN = L.
F6	D3	I	Data Video Signal input pin. Hi-Z input is acceptable to this pin at PDN = L.
G6	D2	I	Data Video Signal input pin. Hi-Z input is acceptable to this pin at PDN = L.
F7	D1	I	Data Video Signal input pin. Hi-Z input is acceptable to this pin at PDN = L.
E6	D0	I	Data Video Signal input pin (LSB). Hi-Z input is acceptable to this pin at PDN = L.
C6	HDI	I	Horizontal SYNC signal input pin. Hi-Z input is acceptable to this pin at PDN = L.
D7	VDI	I	Vertical SYNC signal input pin. Hi-Z input is acceptable to this pin at PDN = L.
C1	VREF	O	On-chip VREF output pin. AVSS level is output on this pin at PDN = L. Connect this pin to Analog Ground via a 0.1 uF or larger capacitor.
C2	IREF	O	IREF output pin. Connect this pin to Analog ground via a 12k ohm resistor (better than +/- 1% accuracy).
A2	DACOUT	O	DAC output pin. Connect this pin to Analog ground via a 390 ohm resistor (better than +/- 1% accuracy).
A4	VOUT	O	Video output pin.
A3	SAG	O	SAG Compensation Input pin
B1	AVDD	P	Analog power supply pin.
B2	AVSS	G	Analog ground pin.
A5, G3	DVDD	P	Digital power supply pin (digital core power supply).
B4, F3	DVSS	G	Digital ground pin (digital core ground).
E7	PVDD	P	Power supply pin for chip pad.
D6	PVSS	G	Ground pin for PVDD.
B3	BVSS	G	Substrate ground pin. Connect this pin to Analog ground

G7	TEST	I	For normal operation, connect to ground.
B7	ATPG	I	For normal operation, connect to ground.
D2	UD4	O	Test output pin. For normal operation, left open.
D1	UD3	O	Test output pin. For normal operation, left open.
E2	UD2	O	Test output pin. For normal operation, left open.
E1	UD1	I/O	Test I/O pin. For normal operation, left open.
F2	UD0	I/O	Test I/O pin. For normal operation, left open.
C3	N.C.	-	Index pin. For normal operation, left open.
A1, A7, G1	N.C.	-	For normal operation, left open.

Analog Output pin status

MODE / PIN name	IREF	VREF	DACOUT	VOUT
PDN = L	Hi-Z	Hi-Z	Hi-Z	Hi-Z
PDN=H, DAC=L VIDEOAMP=L	Output	Output	Hi-Z DAC Power Down	Hi-Z VIDEOAMP Power Down
PDN=H, DAC=H VIDEOAMP=L	Output	Output	Output	VIDEOAMP Power Down
PDN=H, DAC=H VIDEOAMP=H	Output	Output	Output	Output

Electrical Characteristics

(1) Absolute Maximum Ratings

Parameter	Min	Max	Units	Note
Supply voltage DVDD, AVDD, PVDD	-0.3	4.5	V	
Digital Input pin voltage (VinP)	-0.3	PVDD +0.3	V	D[7:0], HDI, VDI, RSTN, PDN, CLKIN, CLKINV, SCL, SDA
Input pin current (Iin)	-10	10	mA	Exclude Power supply pin.
Storage temperature	-40	125	°C	

(Note1)

Power supply voltages are values where each ground pin (DVSS = AVSS = PVSS) is at 0 V(voltage reference).
All power supply ground pins DVSS, AVSS and PVSS should be at same potential.

(2) Recommended Operating Conditions

Parameter	Min	Typ.	Max	Units	Conditions
Supply voltage * AVDD, DVDD	2.7	3.0	3.3	V	AVDD = DVDD
Interface power supply PVDD	1.6	1.8	DVDD	V	
Operating temperature (Ta)	-30		85	°C	

* Power supply voltages are values where each ground pin (PVSS = AVSS = DVSS) is at 0 V(voltage reference).
All power supply ground pins DVSS, AVSS and PVSS should be at same potential.

(3) DC Characteristics

< Operating voltage: DVDD 2.7V~3.3V / PVDD 1.6 V~DVDD, loading condition 15 pF, temperature -30~+85°C >

Parameter	Symbol	Min	Typ	Max	Units	Conditions
Digital input H voltage (VIH)	VIH	0.8PVDD			V	PVDD=1.6 - DVDD
Digital input L voltage (VIL)	VIL			0.2PVDD	V	PVDD=1.6 - DVDD
Digital input leak current	IL			+/-10	uA	
I2C (SDA) L output	VOLC			0.4	V	IOLC = 3mA

(Note)

Digital output pins refer to D[7:0], HDI, VDI, PDN, RSTN, SCL, SDA, CLKIN and CLKINV pin outputs in general term.

(4) Analog Characteristics

< AVDD = 3.0 V, temperature 25 °C >

Parameter	Symbol	Min	Typ	Max	Units
DAC resolution		9		bit	
DAC integral non-linearity (error)		+/- 0.6	+/- 2.0	LSB	
DAC differential non-linearity (error)		+/- 0.4	+/- 1.0	LSB	
DAC output full scale voltage	1.18	1.28	1.38	V	Note1)
DAC output offset voltage			5.0	mV	Note2)
Video Amp Output Gain	5.0	6.0	7.0	dB	Amp Input Level 1Vpp
Video Amp Full scale Level		2.0		Vpp	Note3)
Video Amp THD	-45	-51		dB	100kHz - 5.5MHz Note4)
Video Amp S/N		54		dB	100kHz - 5.5MHz Note4)
LPF Ripple	-1	+/- 0.5	+1	dB	100kHz - 5.5MHz 0dB = 100kHz input
LPF Stop Band Level	20	30		dB	27MHz 0dB = 100kHz input
LPF Group Delay		10	100	ns	GD3MHz - GD6MHz
On-chip reference voltage (VREF)	1.17	1.23	1.30	V	
Reference voltage drift		-50		ppm/°C	

Note1) Values are when a 390 ohm output load, a 12k ohm IREF pin resistor and on-chip VREF are used. Full scale output current is calculated as $I_{out} = \text{full scale output voltage (typ. 1.28 V)} / 390 \text{ ohm} = \text{typ. 3.28 mA}$.
 Note2) A voltage referenced to VSS when a decimal zero voltage is input to DAC.
 Note3) VOUT Output Level Output Load Resistor: 150ohm, Load Capacitor: 15pF Internal Color Bar output
 Note4) Output signal from DAC to which Input data corresponded 1Vpp. This signal is input to AMP.
 Load resistor is 150ohm and Load capacitor is 15pF as shown below figure at (5) Current Consumption.

(5) Current consumption

< Operating voltage : DVDD = AVDD = PVDD = 3.0 V, Ta = +25 °C >

Parameter	Symbol	Min	Typ	Max	Units
Total power consumption		27	35	mA	Note1)
Power-down current 1		10	30	uA	Note2)
Digital part operating current 1		13		mA	Note3)
Analog part operating current 1		14		mA	Note4)
Analog part operating current 2		5.5		mA	Note5)
Analog part operating current 3		0.8		mA	Note6)

Note1) operation at 27 MHz, NTSC mode on-chip 75% color bar output is enabled and Video Amp output is " on " (no external output loads are connected , other than those recommended, connecting-components).

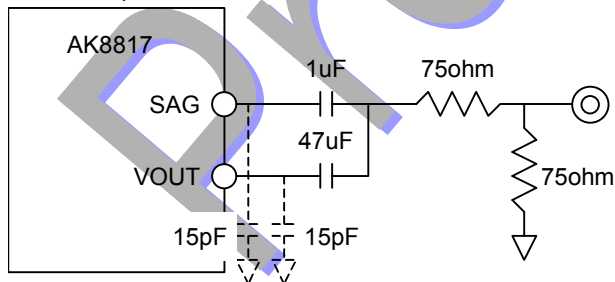

SAG Compensation ON

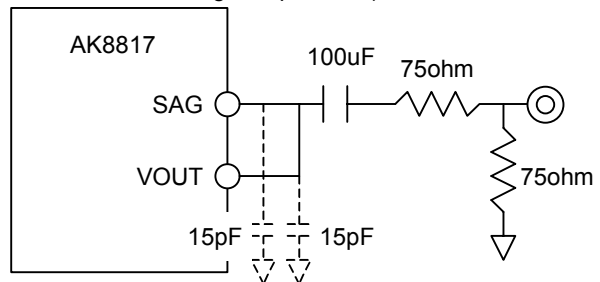

SAG Compensation OFF

Note2) measuring conditions :

input / output settings after power-down sequence are, PDN pin is at GND level, CLKOUT and SDO output are at high level (power supply voltage) with no external connection, input voltage on those input pins is 1/2 level of power supply which are set to accept Hi-Z input at power-down, and TEST = ATPG = GND (or left open).
 Power supplies are AVDD = DVSS = PVDD.
 Each ground pin (DVSS, AVSS, PVSS) is always 0 V (voltage reference).

Note3) Operation at 27 MHz, NTSC mode on-chip 75% color bar output is enabled.

Note4) DAC ON, Video Amp On SAG Compensation On

Note5) DAC ON, Video Amp Off (SAG Compensation Off)

Note6) DAC Off, Video Amp Off (SAG Compensation Off)

AC Timing

< DVDD 2.7 V ~ 3.3 V / PVDD 1.6 V ~ DVDD, Ta at -30 ~ +85 °C > loading condition : CL = 15 pF

(1) CLK

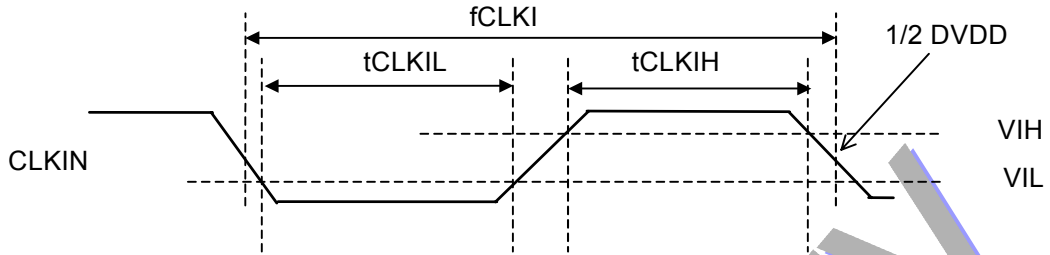

Parameter	Symbol	Min.	Typ.	Max	Unit	Conditions
CLKIN	fCLKI		24.5454		MHz	PIXRT=1 NTSC
			27			PIXRT=0 NTSC/PA
			29.50			PIXRT=1 PAL
CLK duty ratio	pCLKID	40		60	%	
CLK Accuracy				100	ppm	

tCLKIL, tCLKIH : minimum pulse width 12 nS (tr/10%-90%Level Rising/Falling time ≤ 2nS)

Preliminary

(2) Pixel Data Input Timing

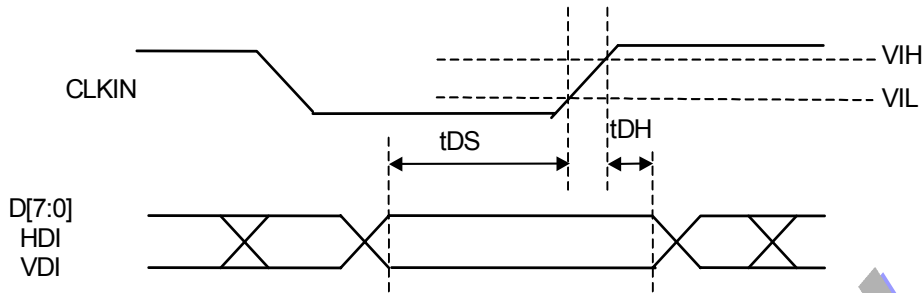

Parameter	Symbol	Min.	Typ.	Max	Unit	Conditions
Data Setup Time	tDS	5			nsec	CLKINV = Low
Data Hold Time	tDH	8			nsec	CLKINV = Low

When CLKINV = High, similar tDS and tDH are specified at the falling edge of CLKOUT.

(3) HSYNC pulse width

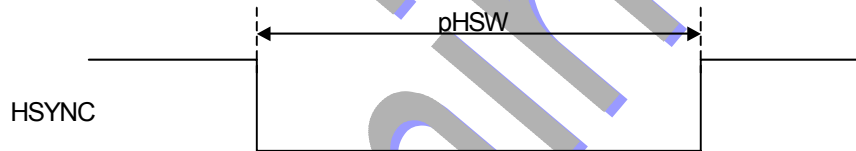

Parameter	Symbol	Min.	Typ.	Max	Unit	Conditions
HDI Pulse Width	pHSW	15	116		CLKs	NTSC (24.5454MHz)
		15	128			27MHz
		15	139			PAL (29.50MHz)

* typical values are calculated by converting the HSYNC pulse width of Analog Video specification into number of system clock pulses.

(4) Reset

(4-1) Reset Timing

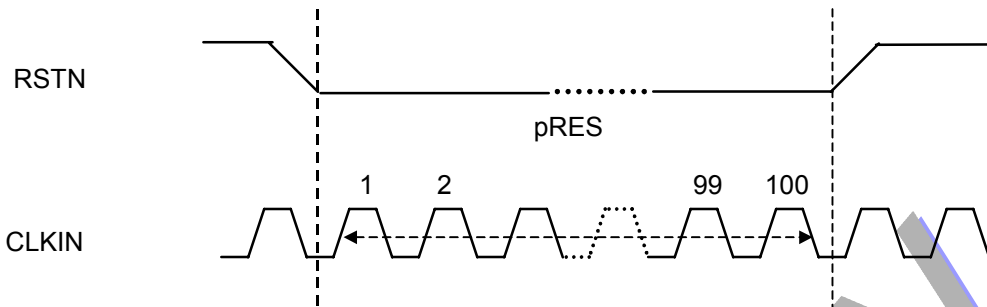

Parameter	Symbol	Min.	Typ.	Max	Unit
RSTN Pulse Width	pRES	100			CLKs

(4-2) Power Down Sequence / Reset Sequence

Before PDN setting (PDN to low), Reset must be enabled for a duration of longer than 100 clock time.

After PDN release (PDN to high), Reset must be enabled for 10 mS or longer till analog part reference voltage & current are stabilized.

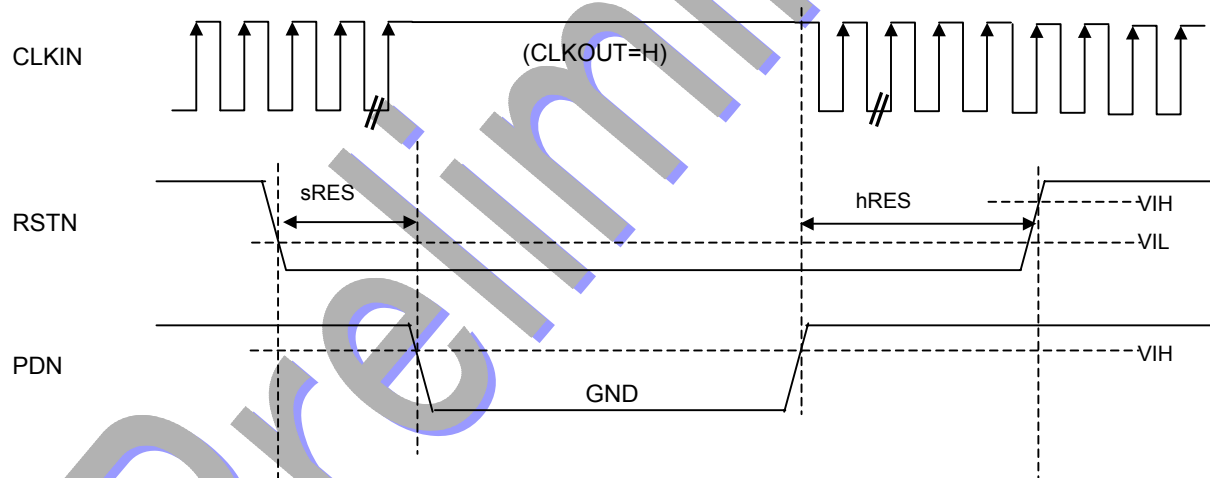

Parameter	Symbol	Min.	Typ.	Max	Unit
RSTN Pulse Width	sRES	100			CLKs
Time from PDN to high to RSTN to high	hRES	10			msec
SCL low duration before RSTN to rise	tSCLL	50			nsec

At power-down, all control signals must be surely connected to either the selected power supply or ground level, and not to VIH / VIL levels.

(4-3) Power Down Sequence/Power up sequence

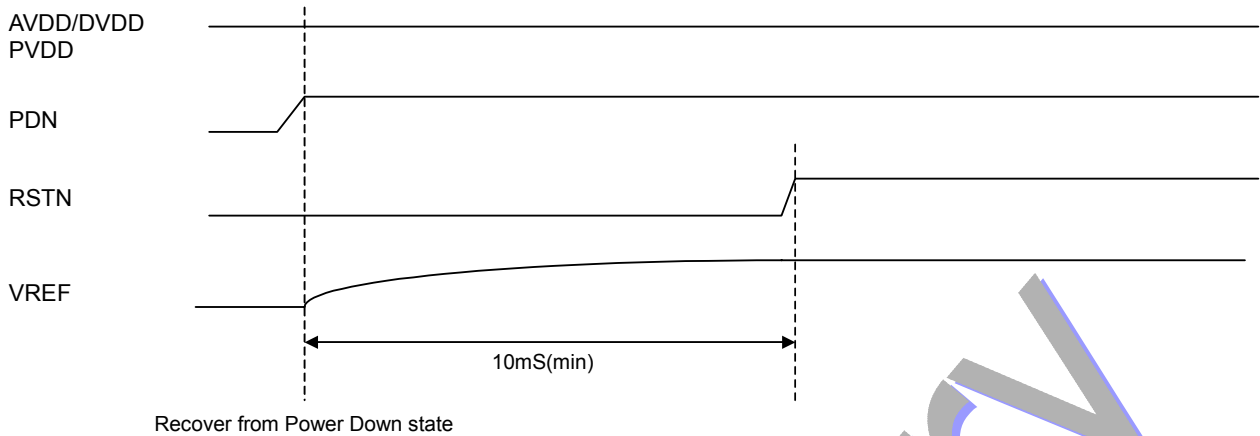

(4-4) Power On Reset

After Power up, It is necessary to make reset sequence until Analog Reference voltage(VREF) becomes stable. PVDD/DVDD/AVDD should be power up at same time or 1st PVDD power up and AVDD/DVDD makes up.

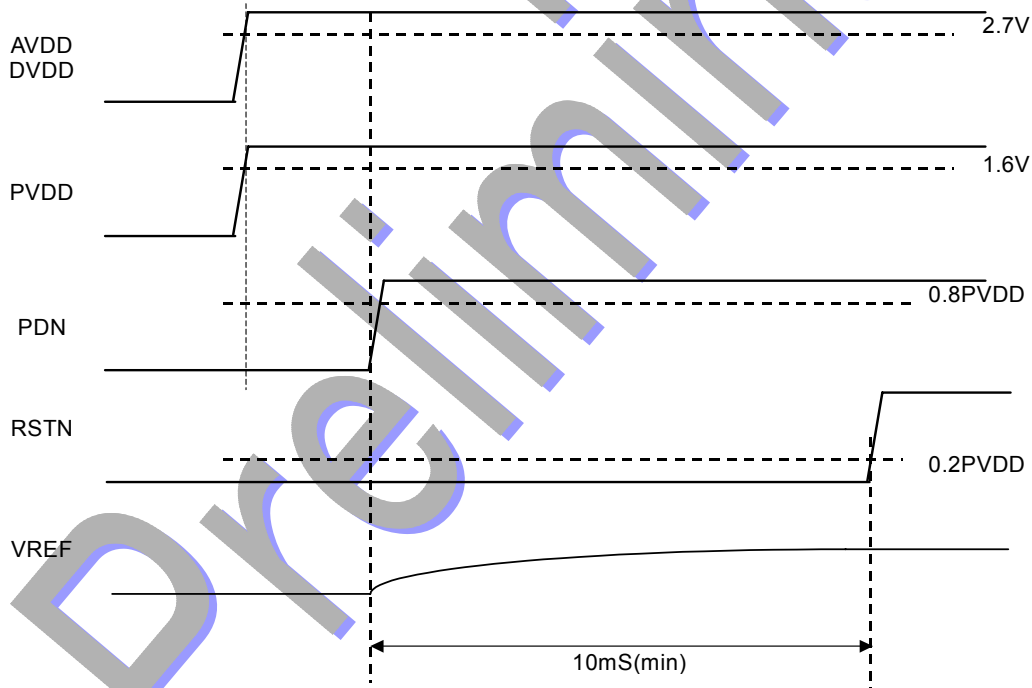

item	Symbol	Min	Typ	Max	Unit	Note
RESETN Pulse width	pRES_PON	10			msec	

Remark: Reset sequence requires clock input.

(5) I2C Bus Input/Output Timing < Ta = -30 ~ +85 °C >

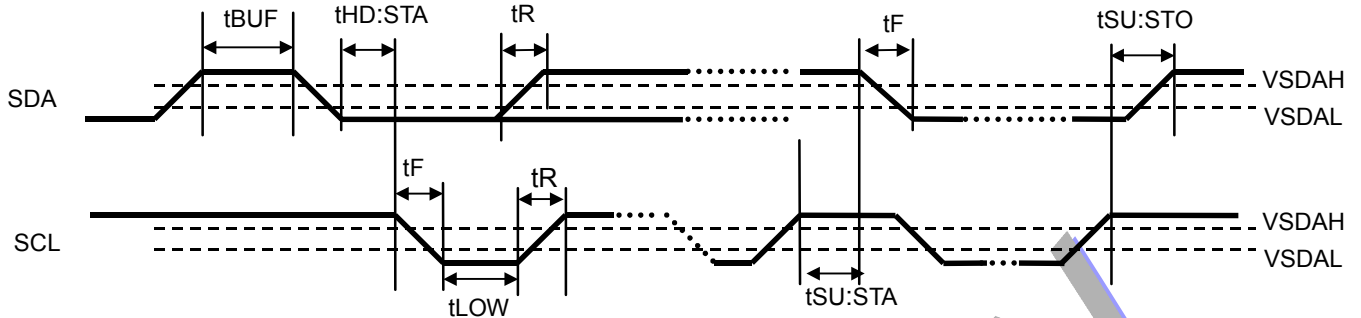

(5-1) Timing 1
 VSDAH: 0.8PVDD
 VSDAL : 0.2PVDD

Parameter	Symbol	Min.	Max.	Unit
Bus Free Time	tBUF	1.3		usec
Hold Time (Start Condition)	tHD:STA	0.6		usec
Clock Pulse Low Time	tLOW	1.3		usec
Input Signal Rise Time	tR		300	nsec
Input Signal Fall Time	tF		300	nsec
Setup Time(Start Condition)	tSU:STA	0.6		usec
Setup Time(Stop Condition)	tSU:STO	0.6		usec

The above I2C bus related timing is specified by the I2C Bus Specification, and it is not limited by the device performance. For details, please refer to the I2C Bus Specification.

(5-2) Timing 2

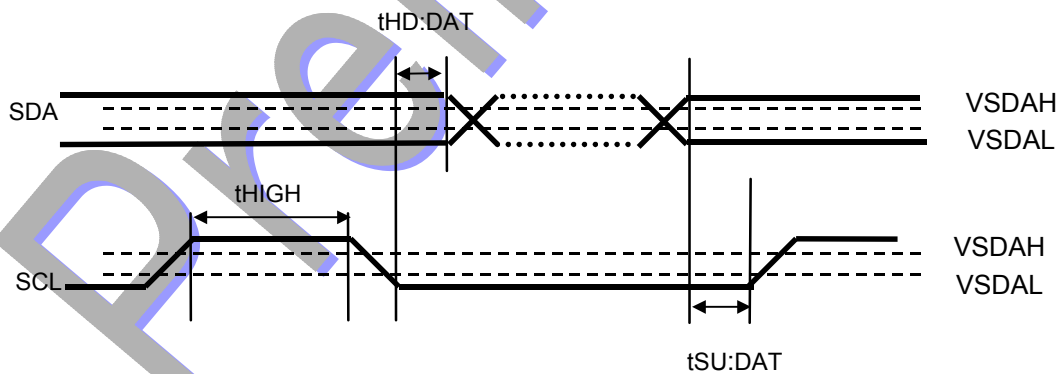

VSDAH: 0.8PVDD
 VSDAL : 0.2PVDD

Parameter	Symbol	Min.	Max.	Unit
Data Setup Time	tSU:DAT	100 (note1)		nsec
Data Hold Time	tHD:DAT	0.0	0.9 (note2)	usec
Clock Pulse High Time	tHIGH	0.6		usec

note 1 : when to use I2C Bus Standard mode, tSU:DAT >- 250 ns must be met.

note 2 : when the AK8817 is used in such bus interface where tLOW is not extended (at minimum specification of tLOW), this condition must be met.

Device Control Interface

The AK8817 is controlled via I2C Bus Control Interface.

[I2C SLAVE Address]

2C Slave Address is **0x40**

[I2C Control Sequence]

(1) Write Sequence

When the Slave Address of the AK8817 Write mode is received at the first byte, Sub Address at the second byte and Data at the third and succeeding bytes are received.

There are 2 operations in Write Sequence - a sequence to write at every single byte, and a sequential write operation to write multiple bytes successively.

(a) 1 Byte Write Sequence

S	Slave Address	w	A	Sub Address	A	Data	A	Stp
	8-bits		1bit	8-bits	1bit	8-bits	1bit	

(b) Multiple Bytes (m-bytes) Write Sequence (Sequential Write Operation)

S	Slave Address	w	A	Sub Address (n)	A	Data(n)	A	Data(n+1)	A	Data(n+m)	A	stp
	8-bits		1bit	8-bits	1bit	8-bits	1bit	8-bits	1bit		8-bits	1bit	

(2) Read Sequence

When the Slave Address of the AK8817 Read mode is received, Data at the second and succeeding bytes are transmitted.

S	Slave Address	r	A	Sub Address (n)	A	rS	Slave Address	F	A	Data1	A	Data2	A	Data3	A	...	Data n	Ā	stp
	8-bits		1	8-bits	1		8-bits		1	8-bits	1	8-bits	1	8-bits	1		8-bits	1	

Abbreviated terms listed above mean :

- S, rS : Start Condition
- A : Acknowledge (SDA Low)
- A- : Not Acknowledge (SDA High)
- stp : Stop Condition
- R/W 1 : Read 0 : Write

- : to be controlled by the Master Device. Micro-computer interface is output normally .
- : to be controlled by the Slave Device. To be output by the AK8817.

Video Encoder Functional Outline

(1) Reset

(1-1) Reset of Serial Interface part (asynchronous reset)

Reset is made by setting RSTN pin to low.

(1-2) Reset of other than Serial Interface blocks

Reset is made by keeping RSTN pin low for a longer than 100 clock time, in normal operation.

(1-3) at Power-On-Reset (including power-down release case)

Follow the power-on-reset sequence.

At the completion of each initialization, all internal registers are set to default values (refer to Register Map). Right after the reset, Video output of the AK8817 is put into Hi-Z condition.

(2) Power-Down

It is possible to put the device into power-down mode by setting the AK8817 power-down pin to GND.

Transition to power-down mode should be followed by the power-down sequence. As for the recover from the power-down mode, it should be followed by the power-down release sequence.

(3) Master Clock

A following clock should be input as a Master clock.

In Encoder Mode operation (a synchronized clock with input data is required)

	When ITU-R BT.601 data is input (PIXRT-bit = 0)	When Square Pixel data is input (PIXRT-bit = 1)
NTSC Encoder	27MHz	24.5454MHz
PAL Encoder	27MHz	29.50MHz

(4) Video Signal Interface

Video input signal (data) should be synchronized in either of the following methods :

* Slave mode operation where synchronization is made with HSYNC (HDI) / VSYNC (VDI).

* ITU-R BT. 656 I / F (EAV decode) (only 27MHz operation)

(5) Pixel Data

Input data to the AK8817 is YCbCr (4:2:2).

Data with Y : 16 ~ 235 and CbCr : 16 ~ 240 should be input.

(6) Video Signal Conversion

Video Re-Composition module converts the multiplexed data (ITU-R BT.601 Level Y, Cb, Cr) into interlaced NTSC-M and PAL-B, D, G, H, I data. Video encoding setting is done by "Control 1 Register ".

(7) Luminance Signal Filter (Luma Filter)

Luminance signal is output via LPF (see x2 Luma Filter in the block diagram).

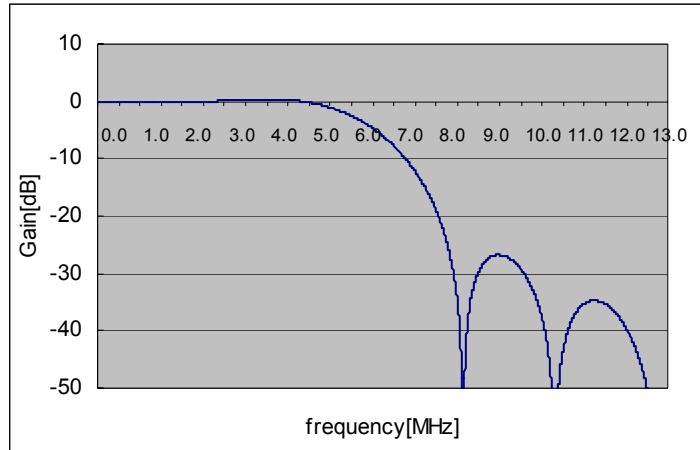

(8) Chroma Signal Filter (Chroma Filter)

Chroma input signal components (Cb, Cr) prior to the modulation go through a 1.3 MHz Band Limiting Filter (see 4:2:2 to 4:4:4 x2 interpolator in the block diagram).

Chroma signal which is modulated by the sub-carrier is output via a low pass filter (Chroma LPF in the block diagram). Frequency response of each filter is shown below.

4:2:2 to 4:4:4 Interpolator Filter

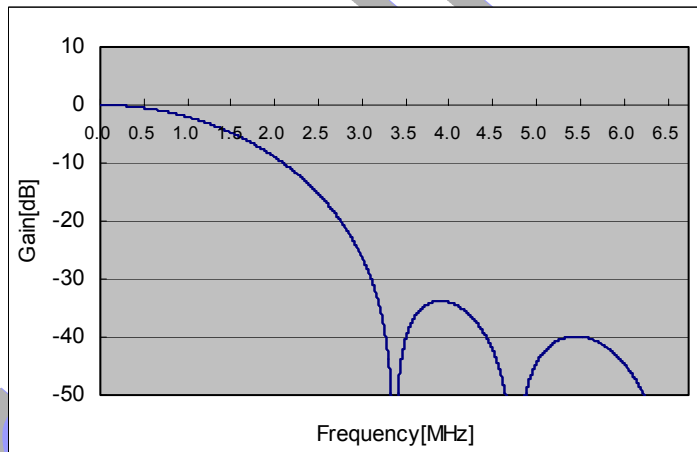

x 2 Interpolator Filter

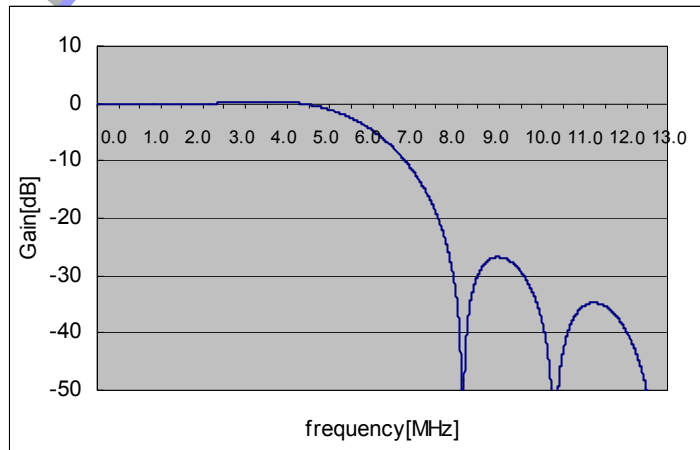

(9) Color Burst Signal

Burst signal is generated by a 32 bit digital frequency synthesizer.
 Color Burst Frequency is selected by mode setting of NTSC / PAL.

Standard	Subcarrier Freq (MHz)	Video Process 1 VMOD-bit
NTSC-M	3.57954545	0
PAL-B,D,G,H,I	4.43361875	1

Burst Signal Table

(10) Sub - Carrier Reset

A function to reset sub-carrier by Color Frame sequence.
 Reset function can be turned "OFF " by setting SCR-bit of Control 1 Register.
 Default value is set to enable Sub-carrier reset.

SCR	0	1
NTSC	Sub-carrier phase is reset in every 2 Frames (4 Fields)	Sub-carrier reset is not done
PAL	Sub-carrier phase is reset in every 4 Frames (8 Fields)	Sub-carrier reset is not done

(11) Setup processing

Setup processing can be performed on Video signal by Control 2 Register Setup-bit.
 Following processing is made on Luminance signal (Y signal) and Chroma signal (C signal) by the Setup processing.

$$Y \text{ Setup} = Y \times 0.925 + 7.5 \text{ IRE} \quad \text{where Y setup is the Luminance signal after Setup processing.}$$

$$C \text{ Setup} = C \times 0.925 \quad \text{where C Setup is the Chroma signal after Setup processing.}$$

(12) Video DAC

The AK8817 has a 9 Bit resolution, current-drive DAC as a video DAC which runs at 29.5 / 24.5454 MHz or 27.00MHz clock frequency.

This DAC is designed to output 1.28 V o-p at full scale under the following conditions loading resistance of 390 ohms, VREF at 1.23 V and IREF pin resistor of 12k ohms.

[VREF] pin should be connected to ground via a 0.1 uF or larger capacitor.

DAC output can be turned "ON" or "OFF" by register setting and current consumption can be lowered.

When the output is turned off, it is put into high impedance condition.

(13) Video Amp

AK8817 has Video amp that can drive 150ohm with Low pass filter. It can also possible to compensate SAG distortion. To compensate SAG external capacitor is 47uF and 1uF as shown following figure. Recommendation voltage when SAG compensation circuit is used is 3V or more. VOUT pin and SAG pin should be shorten when SAG Compensation is not used. Output pin should make AC coupling. SAG Compensation circuit can be set on or off with setting register. In case of not using internal Video amp (Only DAC use case), Video Amp becomes power down. In this case SAG and VOUT should be Open.

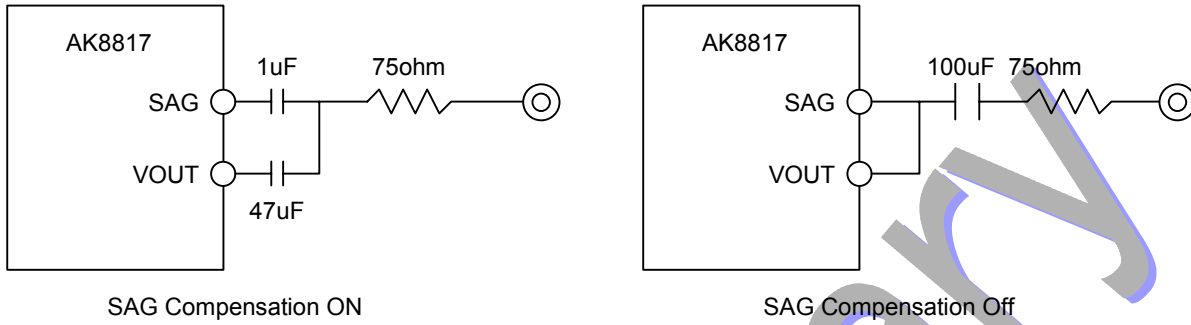

VAMPMD[1:0]	Operation	Conditions
00	Video Amp OFF + SAG Compensation OFF	Only DAC output
01	Video AMP ON + SAG Compensation ON	Recommendation Voltage of DVDD/AVDD is 3v or more.
10	Video Amp ON + No SAG Compensation	SAG pin and VOUT should be shorten.
11	Reserved	

(14) Video Data Interface Timing

Data is captured by a clock which is fed on CLKIN pin.

The Video Encoder receives a clock from a controller (refer to the following diagram).

In Slave mode operation, Synchronization is made with HDI / VDI.

In ITU-R BT.656 mode operation, HDI / VDI are not required.

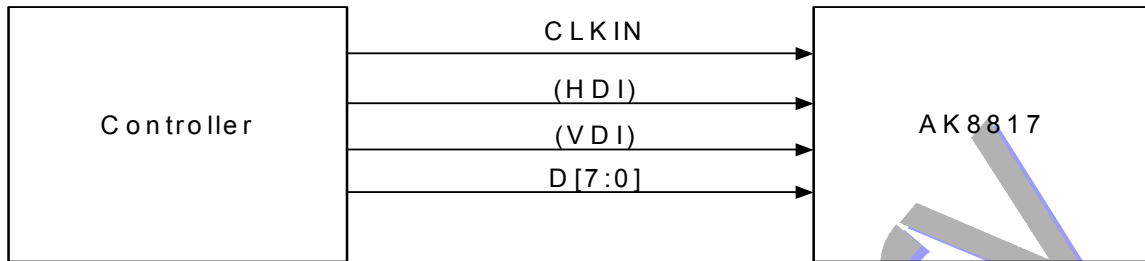

Preliminary

(14-2) Video Interface mode

The AK8817 synchronizes with input signal by the following, 2 interface modes.

- (a) Slave-mode interface where synchronization is made with externally-fed synchronization signals HDI / VDI (HDI / VDI interface)
- (b) ITU-R BT.656 Interface mode (656 interface)

interface mode setting is controlled by [REC656]-bit of Control 2 Register.

REC656-bit	Operation
0	HDI / VDI Slave mode
1	ITU-R BT.656 Interface mode

(a-1) Timing signal (HDI / VDI) VS Data input relation

Horizontal Synchronization (in-line Pixel Sync) is made with HDI synchronization timing signal.

Vertical Synchronization (in-line Frame Line Sync) is made with VDI synchronization timing signal.

Recognition of Video Field (Odd Field or Even Field) is made by VDI input signal which is referenced with HDI.

In normal operation, the AK8817 checks changes of HDI and VDI at the clock edge (CLK synchronization) which becomes a data capture reference position.

At a pixel position where HDI is judged to become " Low ", it is recognized as 0_H (zero th position).

Cb0 data position depends on input data rate (ITU-R BT.601 or Square Pixel data).

Cb0 Data

	At ITU-R BT.601 Data input	At Square Pixel data input
NTSC Encoder	244 th data	236 th data
PAL Encoder	264 th data	310 th data

Video Field is recognized by the VDI relation with HDI.

Field recognition is made as follows :

The AK8817 distinguishes at every Field if it is Odd Field (1st Field) or not. Even Field Sync signal is not usually input.

1) Recognition timing of Odd Field is decided by those timing signal relations which are fed on HDI and VDI pins.

When the VDI falling pulse is input on VDI input pin during the time from 3 clocks prior to the falling edge of HDI timing pulse which is fed on HDI input till 3 clocks prior to the rising edge of HDI timing pulse, the Line is recognized to be Line 4.

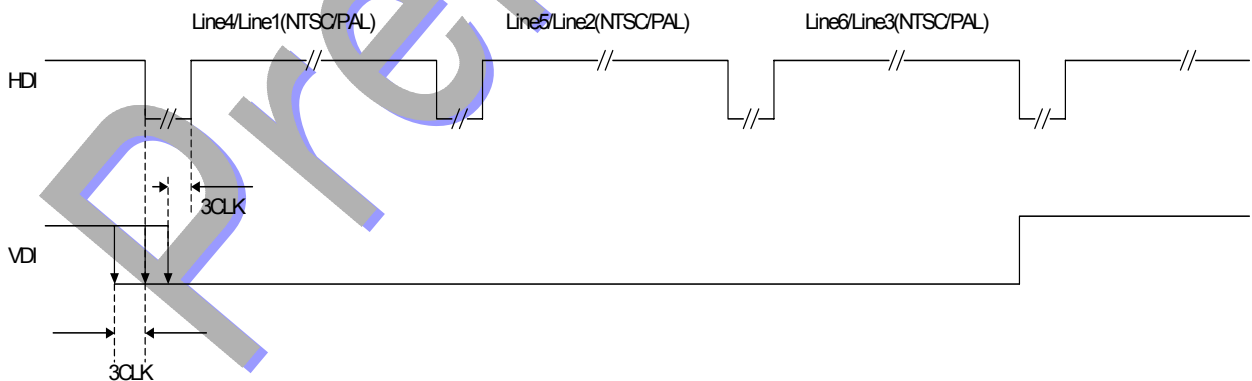

2) Whenever Horizontal / Vertical SYNC signal inputs are not fed as expected in the Video Specifications, in term of timing and # of pulses (kept at " High " level), the AK8817 continues to self-run the operation which is based on the Sync signals, fed just before. But it is recommended to feed Sync signals as specified every time in order to prevent erroneous operation.

3) VD pulse input at other than Odd Field synchronization is ignored (Synchronization is made with Odd Field only).

(a-2) Horizontal Synchronization (Pixel Data synchronization within a Line)

(a-2-1) at ITU-R BT. 601 data input case

(a-2-1-1) NTSC

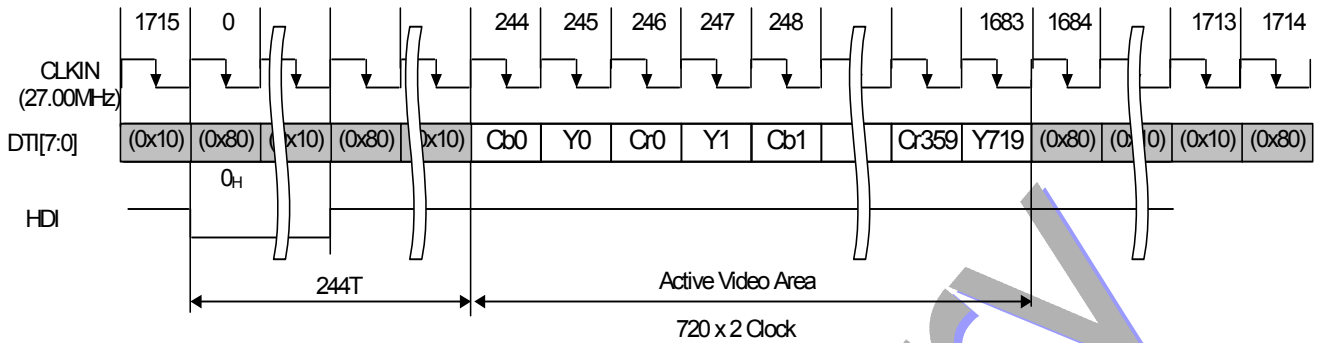

*) when D [7:0], HDI and CLKIN are in same phase relation as a timing example above, the AK8817 takes input data at the falling edge of each CLKIN if CLKEDGE-bit = 1.(CLKINV = 1.)

*) as an input data other than during active video period, Black level (C / Y = 0x80 / 0x10) or other than 0x00 / 0xFF codes in non Hi-Z state should be input.

(a-2-1-2) PAL

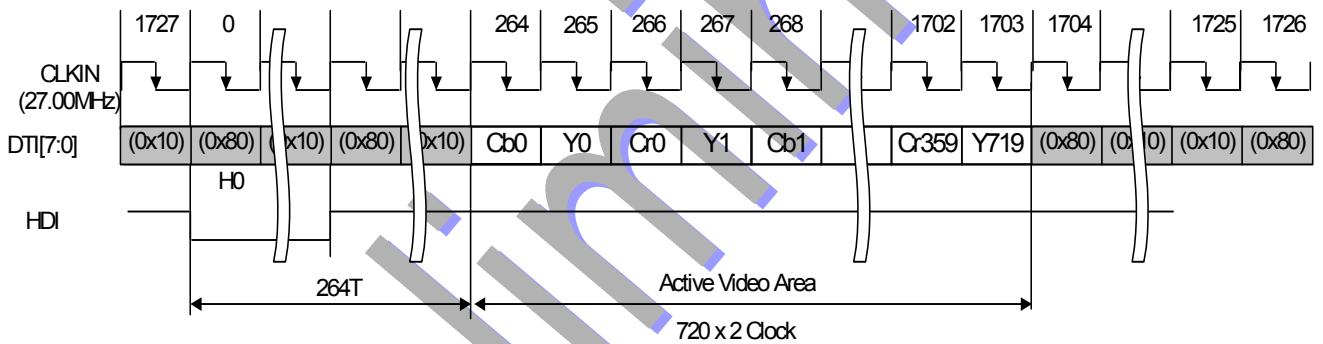

*) when D [7:0], HDI and CLKIN are in same phase relation as a timing example above, the AK8817 takes input data at the falling edge of each CLKIN if CLKEDGE-bit = 1. (CLKINV = 1.)

*) as an input data other than during active video period, Black level (C / Y = 0x80 / 0x10) or other than 0x00 / 0xFF codes in non Hi-Z state should be input.

(a-2-2) at Square Pixel Rate input case

(a-2-2-1) NTSC

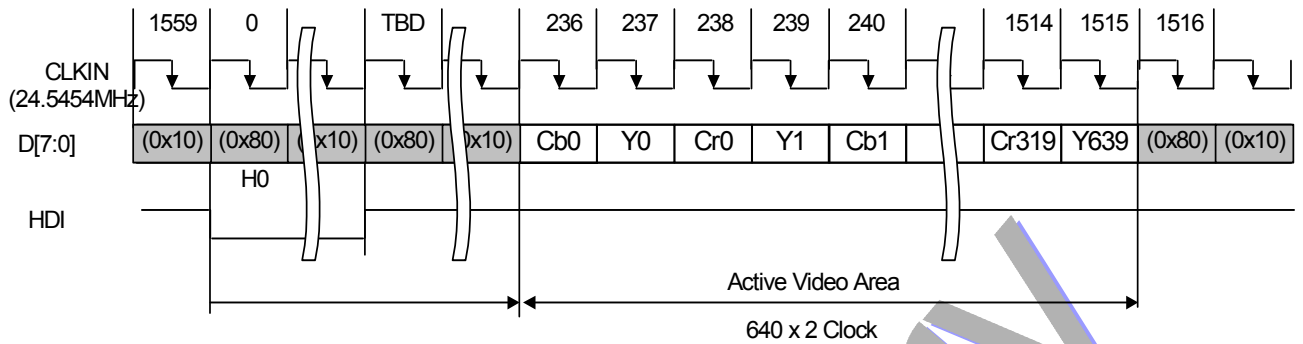

*) when D [7:0], HDI and CLKIN are in same phase relation as a timing example above, the AK8817 takes input data at the falling edge of each CLKIN if CLKINV = 1.

*) as an input data other than during active video period, Black level (C / Y = 0x80 / 0x10) or other than 0x00 / 0xFF codes in non Hi-Z state should be input.

(a-2-2-2) PAL

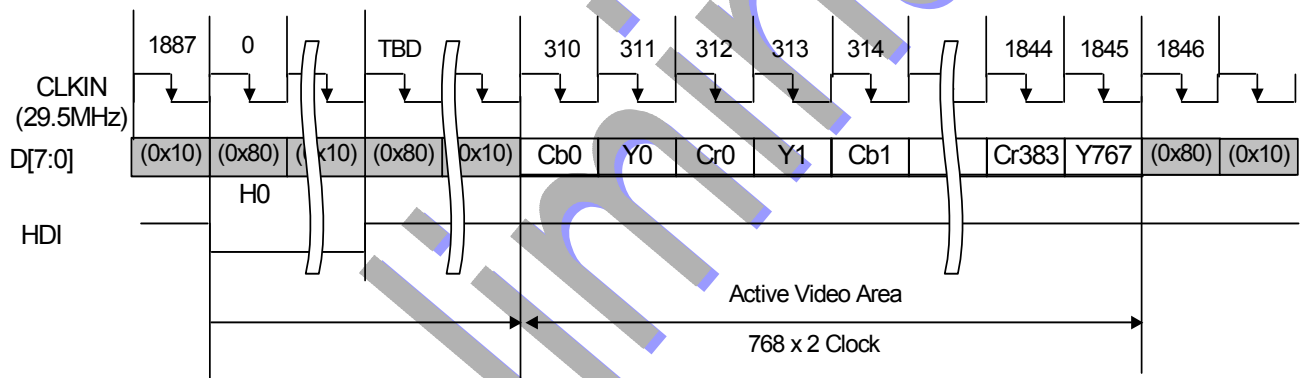

*) when D [7:0], HDI and CLKIN are in same phase relation as a timing example above, the AK8817 takes input data at the falling edge of each CLKIN if CLKINV-bit = 1. (CLKINV = 1.)

*) as an input data other than during active video period, Black level (C / Y = 0x80 / 0x10) or other than 0x00 / 0xFF codes in non Hi-Z state should be input.

(a-3) HDI and VDI relation in each Frame

(a-3-1) NTSC (Frame) 525 Line 480 active lines

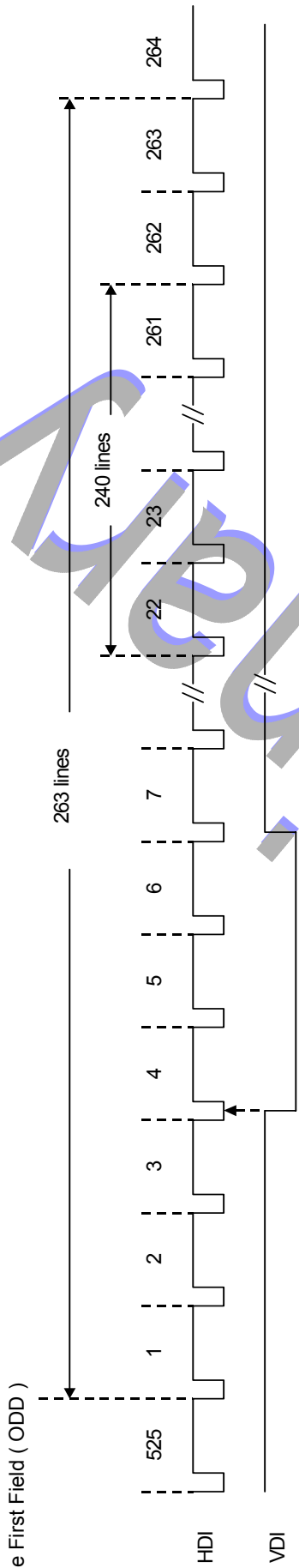

*) VDI negative-going should be fed during the time for 3 clocks prior to negative-going of HDI at L4 till 3 clocks prior to positive-going of HDI. VDI positive-going can occur at arbitrary location, but keep VDI low for 3 line duration time as a rough idea.

The Second Field (EVEN)

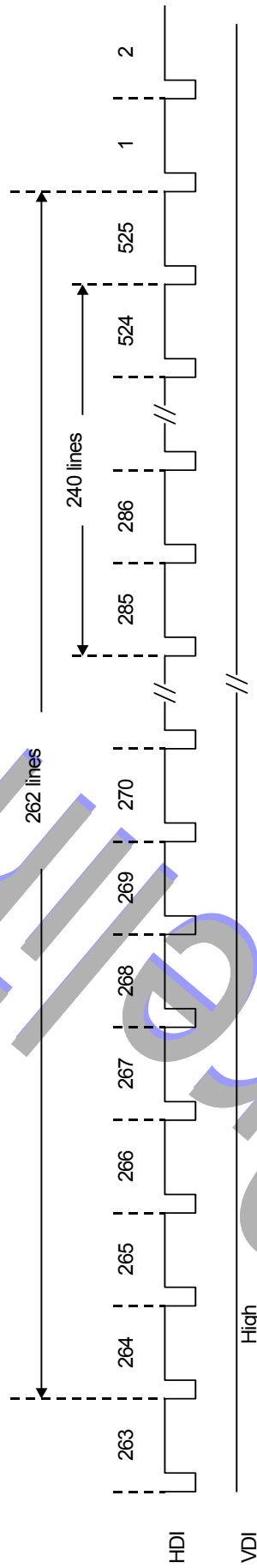

*) VDI negative-going is not required for the Second Field. It is required for the First Field only (VDI fed during the Second Field is ignored).

(a-3-2) PAL (Frame) 625 Line 576 active lines

The First Field (ODD)

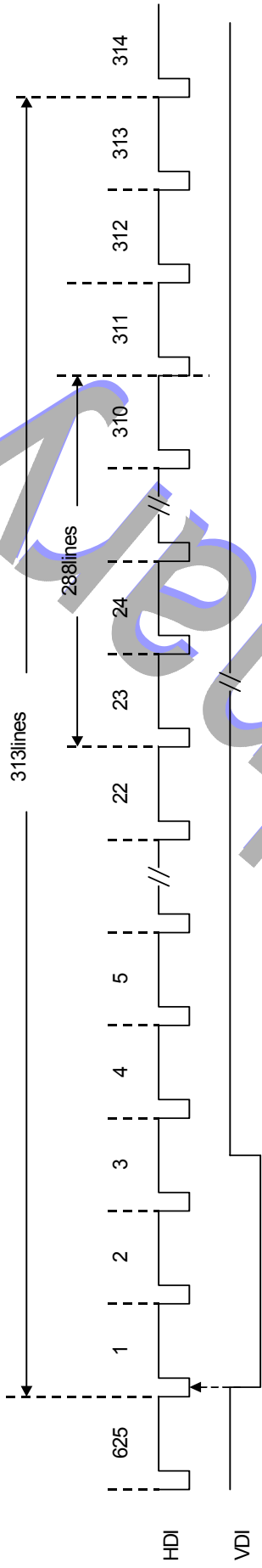

*) VDI negative-going should be fed during the time from 3 clocks prior to negative-going of HDI at L1 till 3 clocks prior to positive-going of HDI. VDI positive-going can occur at arbitrary location, but as a rough idea, keep VDI low for 2.5, or 2 or 3 line- duration time. Data fed at Line 23 is not output on Video output

The Second Field (EVEN)

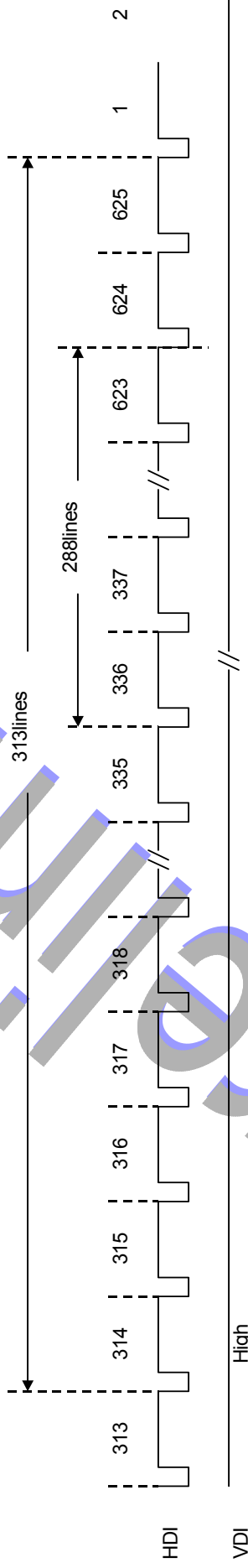

*) VDI negative-going is not required for the Second Field. It is required for the First Field only (VDI fed during the Second Field is ignored). Data fed at Line 623 is not output.

(b-1) ITU-R BT.656 Interface mode

The AK8817 makes a synchronization with an incoming signal by decoding EAV in the signal when ITU-R BT.656 encoded signal is input.

EAV code is located at the following position in the Video stream (this mode of operation is not supported in the Square Pixel clock operation).

	EAV													SAV										
Y/Cb/Cr	Cb	Y	Cr	Y	Cb	Y	Cr	Y			Cb	Y	Cr		Y	Cb	Y	Cr	Y	Cb	Y	Cr	Y	Cb
Data# 525system	360	720	360	721	361	722	361	723			368	736	368		855	428	856	428	857	0	0	0	1	1
Data# 625system	360	720	360	721	361	722	361	723			366	732	366		861	431	862	431	863	0	0	0	1	1

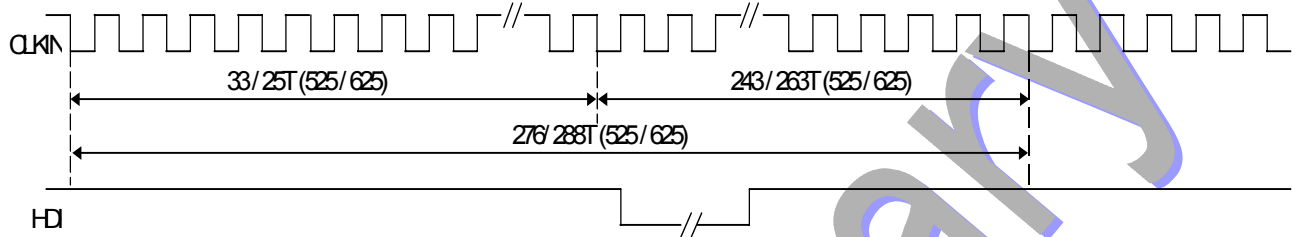

Preliminary

(1) EAV Synchronization

an EAV code which is encoded on input signal is decoded, and the device makes synchronization with its timing. EAV / SAV codes are as follows.

Those codes succeeding 0xFF- 0x00- 0x00 which are fed as input data in 8-bit form become EAV / SAV codes. EAV / SAV codes have following meanings, starting with MSB.

Bit Number		MSB								LSB
WORD	VALUE	7	6	5	4	3	2	1	0	
0	0xFF	1	1	1	1	1	1	1	1	
1	0x00	0	0	0	0	0	0	0	0	
2	0x00	0	0	0	0	0	0	0	0	
3	0xxx	1	F	V	H	P3	P2	P1	P0	

here,

F = 0 : Field 1
 = 1 : Field 2

V = 0 : other than Filed Blanking (V-Blanking)
 = 1 : Filed Blanking (V-Blanking)

H = 0 : SAV
 = 1 : EAV

P3, P2, P1, P0 : Protection Bit

Protection Bit and F / V / H relation is shown in the following table.

F	V	H	P3	P2	P1	P0
0	0	0	0	0	0	0
0	0	1	1	1	0	1
0	1	0	1	0	1	1
0	1	1	0	1	1	0
1	0	0	0	1	1	1
1	0	1	1	0	1	0
1	1	0	1	1	0	0
1	1	1	0	0	0	1

At NTSC data input case

Cb	Y	Cr	Y	Cb	Y	Cr	Y	Cb	Y	Cr	Y	Cb	Y	Cr	Y
359	718	359	719	360	720	360	721	428	856	428	857	0	0	0	1
EAV									SAV							

At PAL data input case

Cb	Y	Cr	Y	Cb	Y	Cr	Y	Cb	Y	Cr	Y	Cb	Y	Cr	Y
359	718	359	719	360	720	360	721	431	862	431	863	0	0	0	1
EAV									SAV							

(1-1) EAV / SAV Code and Line Synchronization

The AK8817 makes Vertical synchronization (Line synchronization) when F-bit in EAV makes transition from " 1 " to " 0 " .

F-bit of EAV / SAV and Line relation is as follows

F-bit	NTSC	PAL
0	Line4 – Line265	Line1 – Line312
1	Line266 – Line525 Line1 – Line3	Line313 – Line625

For reference, V-bit of EAV / SAV and Line relation is also shown below.

Field	V-bit	NTSC	PAL
Field 1	Start (V=1)	Line1 – Line19	Line624 – Line625 – Line22
	End (V=0)	Line20 – Line263	Line23 – Line310
Field 2	Start (V=1)	Line264 – Line282	Line311 – Line335
	End (V=0)	Line283 – Line525	Line336 – Line623

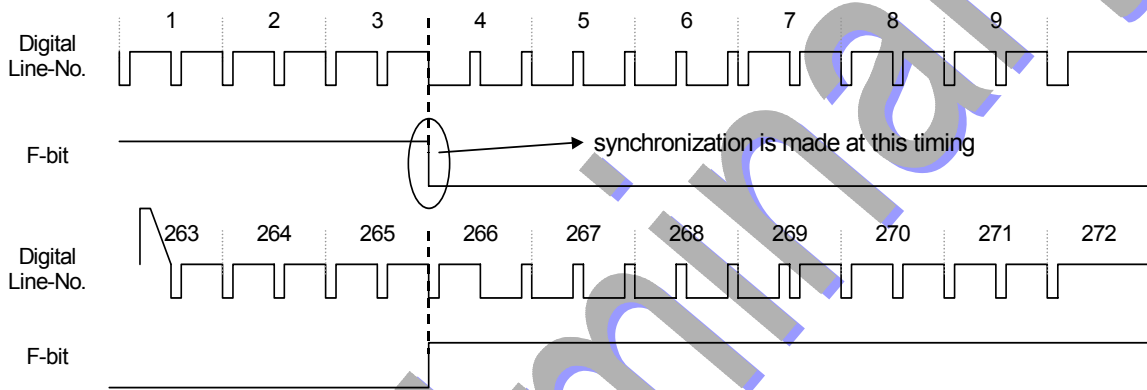

Line Synchronization by EAV at NTSC input case

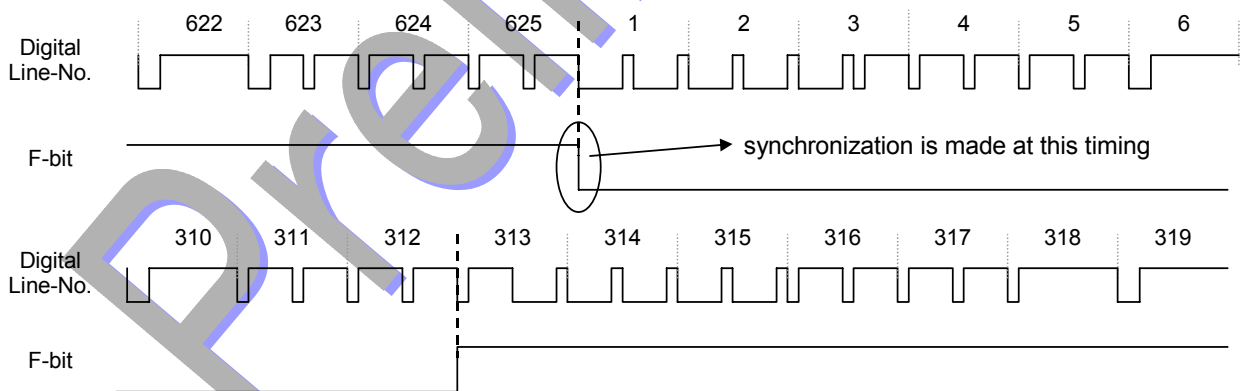

Line Synchronization by EAV at PAL input

(15) On-chip Color Bar

The AK8817 can output Color Bar signal.

Color Bar signal to be generated has 100 % amplitude and 75 % Saturation levels.

Color Bar signal is output by setting register.

When to output Color Bar signal, there are 2 modes of operation – one is external Sync timing mode for normal operation, and the other is internal self-operation mode.

In internal self-operating mode, required timing is internally generated automatically. Namely, it is no need to input synchronization timing from outside of the chip.

Operation mode setting is done by Control 1 Register .

When BBG-bit is set, BBG-bit is prioritized (Black Burst is output).

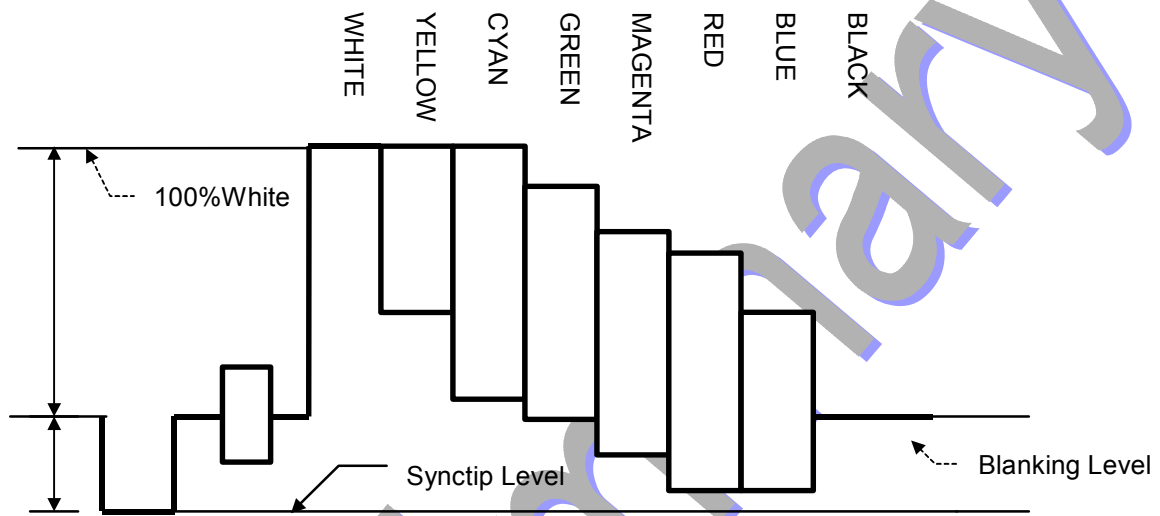

The following values are code for ITU-R. BT601

	WHITE	YELLOW	CYAN	GREEN	MAGENTA	RED	BLUE	BLACK
Cb	128	44	156	72	184	100	212	128
Y	235	162	131	112	84	65	35	16
Cr	128	142	44	58	198	212	114	128

(16) Black Burst Signal generation function

The AK8817 can output Black Burst signal (Black level output).

When to output Black Burst signal, there are 2 modes of operation – one is external Sync timing mode for normal operation , and the other is internal self-operation mode.

In internal self-operation mode, required timing is internally generated automatically. Namely, it is no need to input synchronization timing from outside of the chip.

When BBG-bit of [Control 1 Register] is set to “1”, same operation is processed as in the case where fixed-16 Y signal and

fixed-128 Cb / Cr signal outputs are input.

Operation mode setting is done by Control 1 Register setting.

(17) Video ID

The AK8817 supports to encode the Video ID (EIAJ CPR-1204) which distinguishes the aspect ratio etc..

This is also used as CGMS (Copy Generation Management System).

Turning "ON/OFF" of this function is made by setting both VMOD-bit = 0 and VBID-bit = 1 of { Control 1 Register (0x00) }.
And data to be set is written into { VBID / WSS Data1 & 2 Registers (0x02,0x03)}.

Video ID information is the highest order of priority information among VBI information

VBID Data Update timing

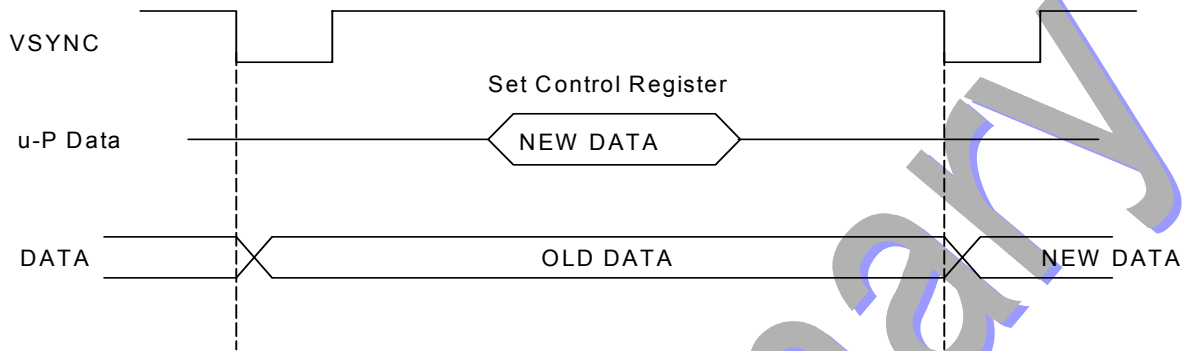

VBID Code assignment

20 bit data is configured with WORD0 = 2 bit, WORD1 = 4 bit, WORD2 = 8 bit and CRC = 6 bit.

CRC is automatically calculated and added by the AK8817.

Default values of CRC polynomial expression $X^6 + X + 1$ are all ones.

-data configuration

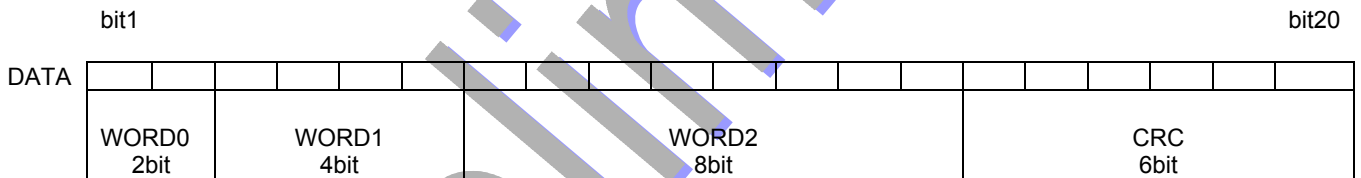

VBID Waveform

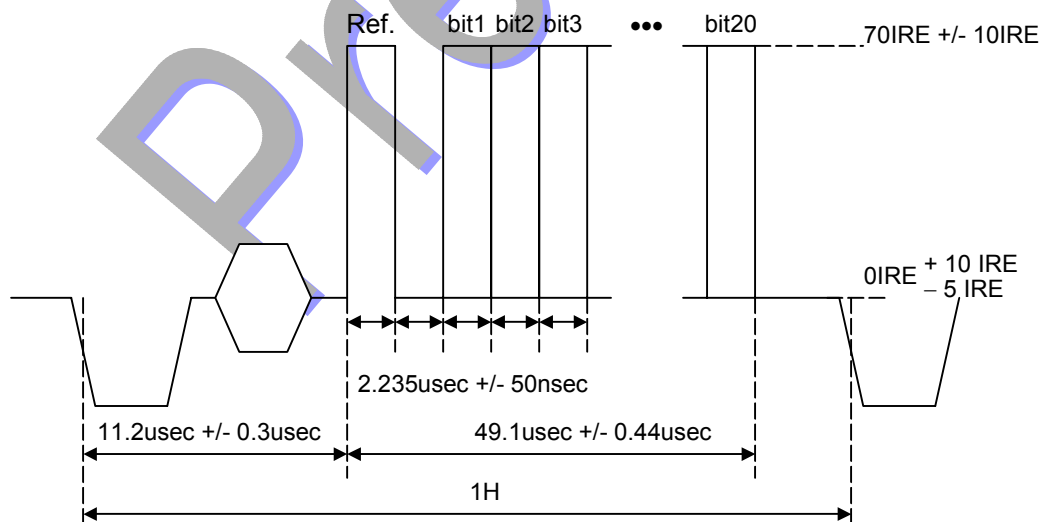

	525/60 System
Amplitude	70IRE
Encode Line	20/283

(17) WSS function

The AK8817 supports to encode the WSS (ITU-R. BT.1119) which distinguishes the aspect ratio and sets CGMS-A etc.. Turning "ON/OFF" of this function is made by setting both VMOD-bit = 1 and WSS-bit = 1 of { Control 1 Register (0x00) }. And data to be set is written into { VBID / WSS Data1 & 2 Registers (0x02, 0x03)}.

WSS Data Update timing

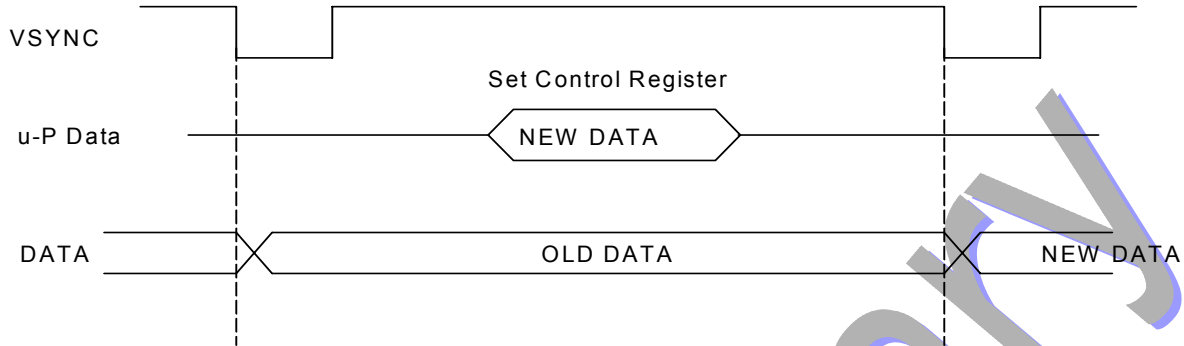

WSS Waveform

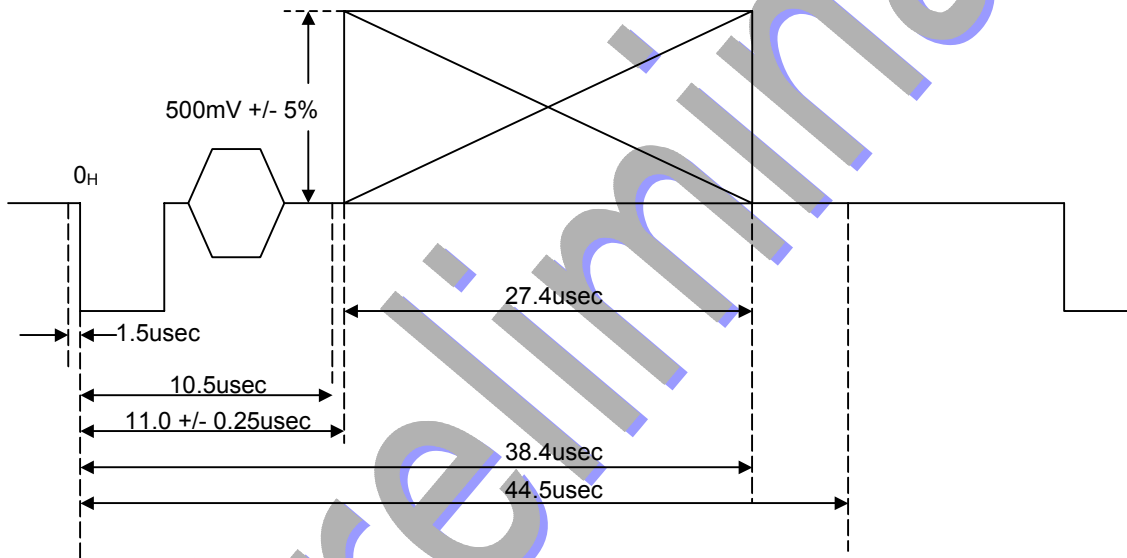

Encode line : former half of Line 23 (Blank output during latter half)

Coding : Bi-phase modulation coding

Clock : 5 MHz (Ts = 200 nS)

Encoding details as follows

Run-in	Start code	Group 1 Aspect ratio	Group 2 Enhanced Services	Group 3 Subtitles	Group4 Reserved
29 elements	24 elements	24 elements	24 elements	18 elements	18 elements
		Bit numbering 0 1 2 3 LSB MSB	Bit numbering 4 5 6 7 LSB MSB	Bit numbering 8 9 10 LSB MSB	Bit numbering 11 12 13 LSB MSB
		0 : 000111 1 : 111000	0 : 000111 1 : 111000	0 : 000111 1 : 111000	0 : 000111 1 : 111000
0x1F1C71C7	0x1E3C1F				

SYNC Signal waveform, Burst Waveform generator

(1) NTSC-J

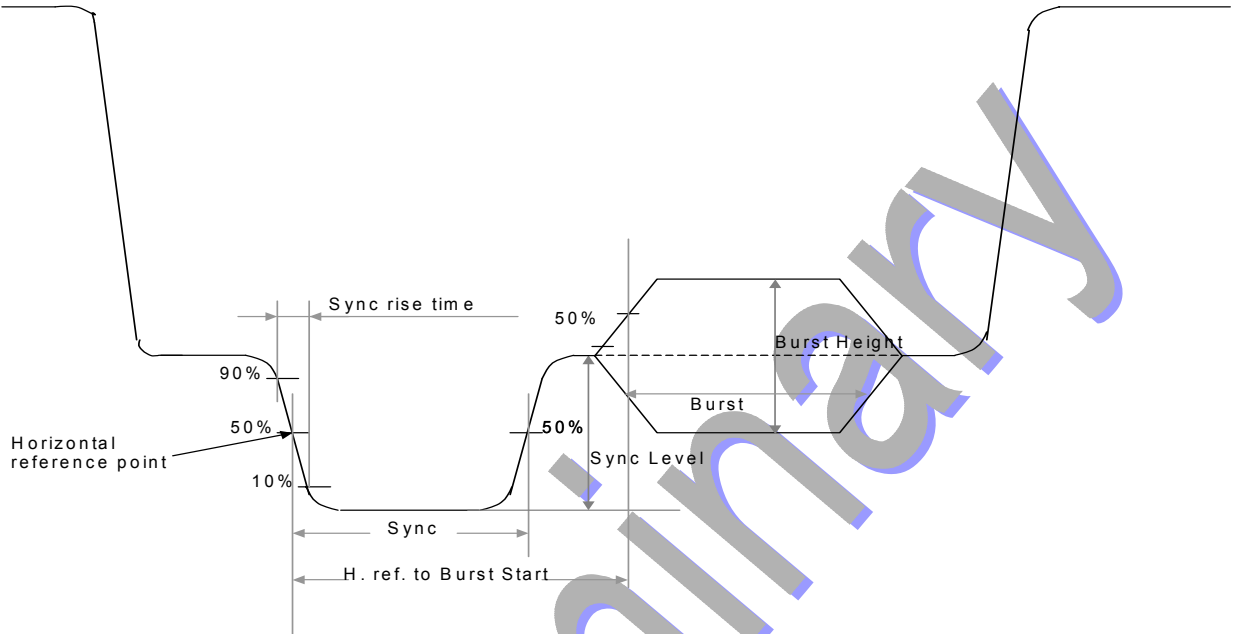

	measurement point	value	Consumer Quality tolerance	units
Total line period(derived)		63.556		usec
Sync Level		40	+/- 3	IRE
Sync rise time	10% - 90%	140	Max 250	nsec
Horizontal Sync width	50%	4.7	+/- 0.1	usec
Horizontal reference point to burst start	50%	19	defined by SC/H	cycles
Burst *	50%	9	+/- 1	cycles
Burst Height **		40	+/- 3	IRE

* there is a case where tolerance of Sync rise time is added to Sync width tolerance.

* Measurement of Burst time length is made between the Burst start point which is defined as the zero-cross point, preceding the first half-cycle of the sub-carrier where Burst amplitude becomes higher than 50 % level and the Burst end point, defined in the same manner.

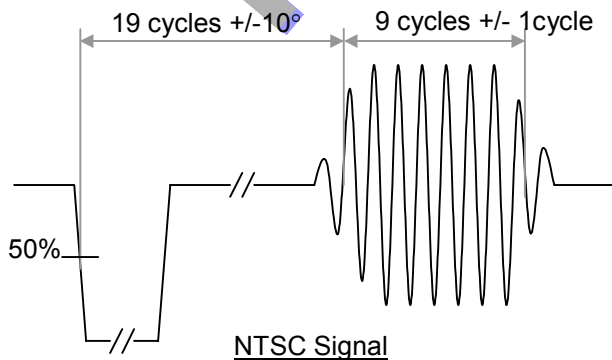

(2) Vertical Sync Signal timing (NTSC)

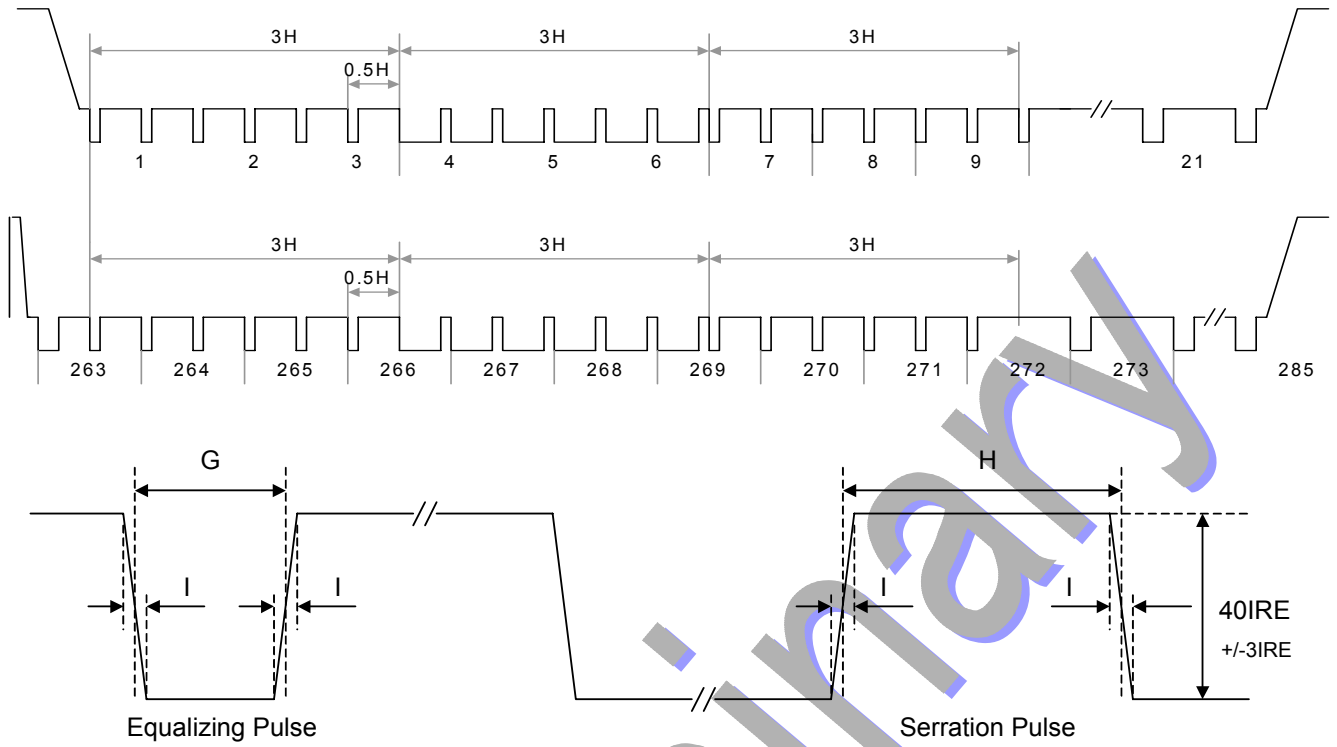

Equalizing Pulse and Serration Pulse

Symbol		Measurement point	Value	Recommended tolerance	units
G	Pre-equalizing pulse width	50%	2.3	+/- 0.1	usec
H	Vertical serration pulse width	50%	4.7	+/- 0.2	usec
G	Post-equalizing pulse width	50%	2.3	+/- 0.1	usec
I	Sync rise time		140	Max 250	nsec

* there is a case where tolerance of Sync rise time is added to Pulse width tolerance.

(3) PAL-B,D,G,H,I

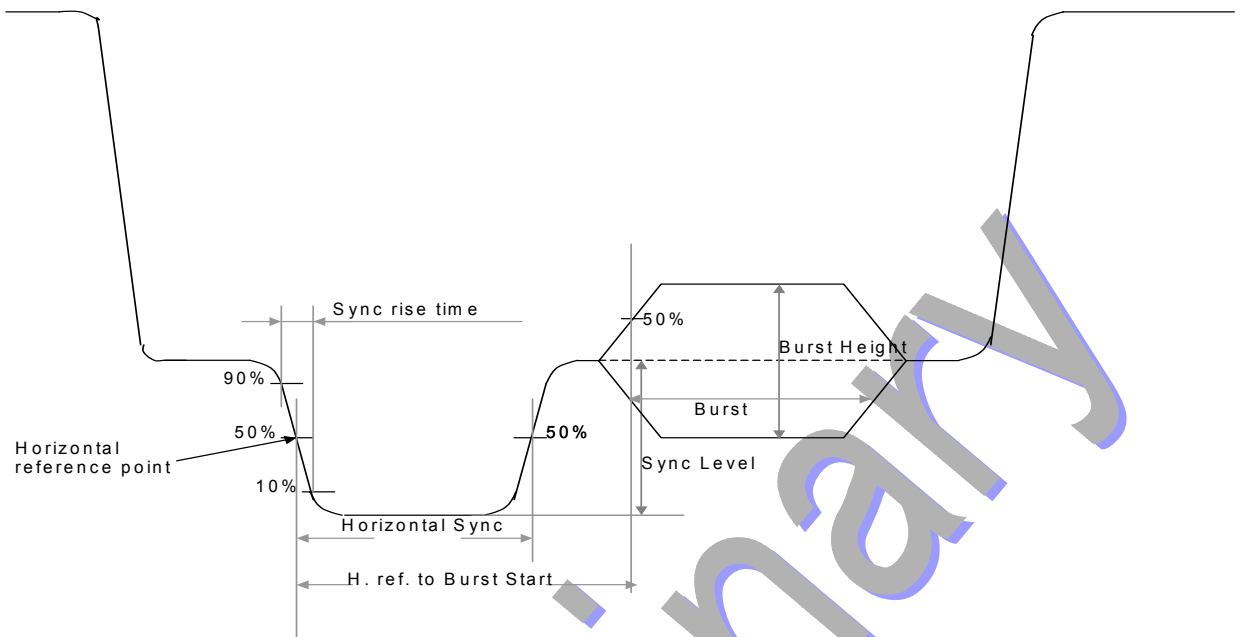

	measurement point	value	Consumer Quality tolerance	units
Total line period(derived)		64.0		usec
Sync Level		300	+/- 20	mV
Sync rise time	10% - 90%	0.2	Max 0.3	usec
Horizontal Sync width	50%	4.7	+/- 0.2	usec
Horizontal reference point to burst start	50%	5.6	+/- 0.1	usec
Burst *	50%	10	+/- 1	cycles
Burst Height **		300	+/- 30	mV

* there is case where tolerance of Sync rise time is added to Sync width tolerance.

(4) Vertical Sync Signal timing and Burst Phase

PAL-B,D,G,H,I

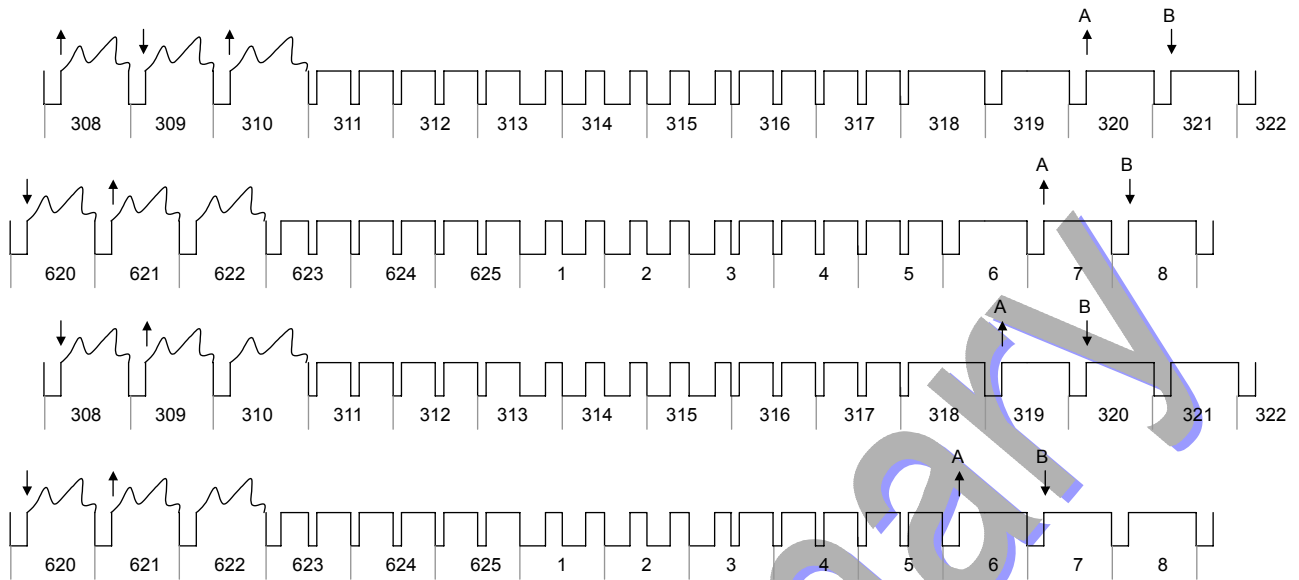

A : Phase of Burst : nominal Value + 135°
 B : Phase of Burst : nominal Value - 135°

Since Burst frequency and Line frequency are not practically in integer-multiple relation, specified phase value is not exactly 135 degrees.

Diagram below shows phase direction.

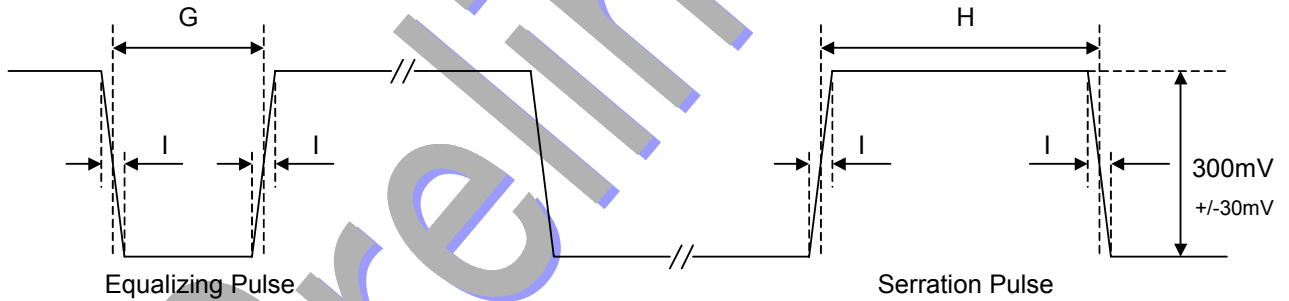

Equalizing Pulse and Serration Pulse

Symbol		Measurement point	Value	Recommended tolerance	units
G	Pre-equalizing pulse width	50%	2.35	+/- 0.1	usec
H	Vertical serration pulse width	50%	4.7	+/- 0.2	usec
G	Post-equalizing pulse width	50%	2.35	+/- 0.1	usec
I	Sync rise time		200	Max 300	nsec

* there is a case where tolerance of Sync rise time is added to Pulse width tolerance.

Register Map

Address	Register	Default	R/W	Function
0x00	Control 1 Register	0x00	R/W	Mode set Register
0x01	Control 2 Register	0x00	R/W	Mode set Register
0x02	VBID/WSS Data 1 Register	0x00	R/W	VBID data is set, WSS data is set
0x03	VBID/WSS Data 2 Register	0x00	R/W	VBID data is set, WSS data is set
0x04	Input Control Register	0x00	R/W	Input control register for out-of-standard quality input signal
0x05	Device ID & Revision ID Register	0x17	R	Register for Device ID and Revision ID

Preliminary

Control 1 Register (R/W) [Address 0x00]**Sub Address 0x00****Default Value 0x00**

bit 7	bit 6	bit 5	bit 4	bit 3	bit 2	bit 1	bit 0
DAC	BBG	CBG	MASMD	WSS	VBID	SCR	VMOD
Default Value							
0	0	0	0	0	0	0	0

Control 1 Register Definition

BIT	Register Name		R/W	Definition
bit 0	VMOD	Video Mode bit	R/W	0: NTSC 1: PAL
bit 1	SCR	Sub-Carrier Reset bit	R/W	0 : Sub-Carrier Reset 1 : Sub-Carrier Reset off
bit 2	VBID	VBID Set bit	R/W	0 : VBID OFF 1 : VBID ON
bit 3	WSS	WSS Set bit	R/W	0 : WSS OFF 1 : WSS ON
bit 4	MASMD	Master Mode bit	R/W	Master Mode bit to set Sync mode when Color Bar signal and Black Burst signal are generated 0 : operation by an external Sync timing 1 : operation by an internal self-operating mode (master mode) note) Master mode bit is still valid in normal data input, but output video is not synchronized.
bit 5	CBG	Color Bar Generator bit	R/W	0: OFF 1: ON when BBG is set, BBG is prioritized.
bit 6	BBG	Black Burst Generator bit	R/W	0 : OFF 1 : ON
bit 7	DAC	DAC Set bit	R/W	0 : DAC OFF 1 : DAC ON

Control 2 Register (R/W) [Address 0x01]

Sub Address 0x01

Default Value 0x00

bit 7	bit 6	bit 5	bit 4	bit 3	bit 2	bit 1	bit 0
Reserved	Reserved	Reserved	VAMPMD1	VAMPMD0	SETUP	REC656	PIXRT
Default Value							
0	0	0	0	0	0	0	0

Control 2 Register Definition

BIT	Register Name		R/W	Definition
bit 0	PIXRT	Pixel Rate Set bit	R/W	Pixel rate setting is done. 0 : ITU-R BT.601 data input (at 27 MHz rate) 1 : Square Pixel data input NTSC : 24.5454 MHz PAL : 29.50 MHz
bit 1	REC656	Rec656 Set bit	R/W	Synchronization mode setting is done. 0 : synchronization is made with HDI / VDI input. 1 : synchronization is made with ITU-R BT.656 data input
bit 2	SETUP	Setup bit	R/W	Set-up setting is done 0 : with no set-up 1 : with 7.5 IRE set-up
bit 3 ~ bit 4	VAMPMD0 ~ VAMPMD1	Video Amp Mode Set bit	R/W	Operation mode for Video Amp. VAMPMD[1:0] 00: Video Amp OFF + SAG Compensation OFF 01: Video AMP ON + SAG Compensation ON 10: Video Amp ON + No SAG Compensation 11: Reserved
bit 5 ~ bit 7	Reserved	Reserved bit	R/W	Set "0"

VBID/WSS 1 Register (R/W) [Address 0x02]
VBID/WSS 2 Register (R/W) [Address 0x03]

Video ID and WSS data setting are made. A common data register is used for both video ID and WSS data.

When VBID bit of mode register is set in NTSC mode, data is for VBID data ,and when WSS bit of Control 1 Register is set in

PAL mode, data is for WSS data.

When VBID-bit is "1" and VMOD-bit is "0" in Control 1 Register , the following bits are assigned.

Sub Address 0x02							default Value 0x00
bit 7	bit 6	bit 5	bit 4	bit 3	bit 2	bit 1	bit 0
VBID7	VBID8	VBID9	VBID10	VBID11	VBID12	VBID13	VBID14
Default Value							
0	0	0	0	0	0	0	0

Sub Address 0x03							default Value 0x00
bit 7	bit 6	bit 5	bit 4	bit 3	bit 2	bit 1	bit 0
Reserved	Reserved	VBID1	VBID2	VBID3	VBID4	VBID5	VBID6
Default Value							
0	0	0	0	0	0	0	0

Note) "0" should be written into reserved bits.

VBID1 ---- VBID14 above correspond to the bit 1 ---- bit 14 which are described at { VBID Data Code Assignment } in { (14) Video ID } section.

A 6-bit CRC code from bit 15 ~ bit 20 is automatically added by the AK8817.

Data is retained till data is updated to a new one.

Following bits are assigned when WSS-bit is "1" and VMOD-bit is "1" in Control 1 Register .

Sub Address 0x02							default Value 0x00
bit 7	bit 6	bit 5	bit 4	bit 3	bit 2	bit 1	bit 0
G2-7	G2-6	G2-5	G2-4	G1-3	G1-2	G1-1	G1-0
Default Value							
0	0	0	0	0	0	0	0

Sub Address 0x03							default Value 0x00
bit 7	bit 6	bit 5	bit 4	bit 3	bit 2	bit 1	bit 0
Reserved	Reserved	G4-13	G4-12	G4-11	G3-10	G3-9	G3-8
Default Value							
0	0	0	0	0	0	0	0

Note) WSS data is written with 0x01 first, then 0x02 in this order.

When the 2nd byte (0x02) of WSS data is written, the AK8817 interprets that data is updated to a new one and then encodes it to the next video line (Line 23).

Data is retained till data is updated to a new one.

Input Control Register (R/W) [Address 0x04]

This is an out-of-standard quality input signal control register.

Sub Address 0x04**default Value 0x00**

bit 7	bit 6	bit 5	bit 4	bit 3	bit 2	bit 1	bit 0
Reserved	CBCR	VD2	VD1	VD0	HD2	HD1	HD0
0	0	0	0	0	0	0	0

Adjustment of Sync input timing is made.

BIT	Register Name		R/W	Definition
bit 0 ~ bit 2	HD0 ~ HD2	HDI Input Delay	R/W	HDI signal input is delayed by the set value. HD [2:0] system clock count delay (+ 0 ~ + 7 CLK delay)
bit 3 ~ bit 5	VD0 ~ VD2	VDI Input Delay	R/W	VDI signal input is delayed by the set value. VD [2:0] system clock count delay (+ 0 ~ + 7 CLK delay)
bit 6	CBCR	Exchange CbCr	R/W	Cb, Cr timing data are interchanged at CBCR = 1.
bit 7	Reserved	Reserved	R/W	Reserved

Device ID and Revision ID Register (R) [Address 0x05]

Register to show Device ID & Revision of the AK8817.

Device ID for AK8817 is 0x17(decimal)

Initial Version of the Revision ID is 0x00.

Revision number is modified only when a control software needs to be modified.

Sub Address 0x5**default Value 0x17**

bit 7	bit 6	bit 5	bit 4	bit 3	bit 2	bit 1	bit 0
Rev1	REV0	DEV5	DEV4	DEV3	DEV2	DEV1	DEV0
0	0	0	1	0	1	1	1

Device ID and Revision ID Register Definition

BIT	Register Name		R/W	Definition
bit 0 ~ bit 5	DEV0 ~ DEV2	Device ID bit	R	To show Device ID Device ID is 0x17h.
bit 6 ~ bit 7	REV0 ~ REV2	Revision ID bit	R	To show Revision information Revision ID is updated when software modification is to be expected. It is 0x00.

System Connection Example

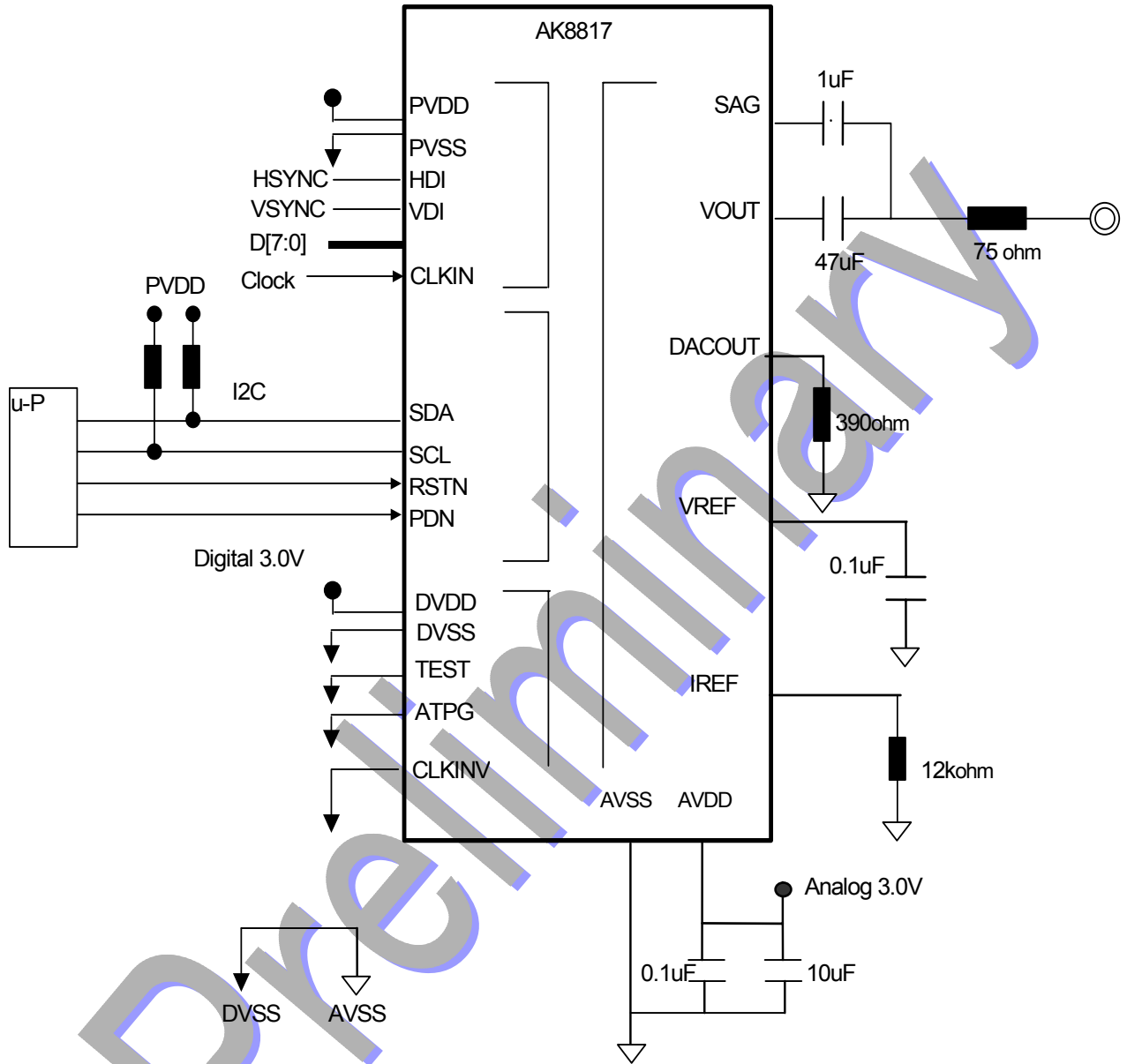

Package Drawing

41pin FBGA

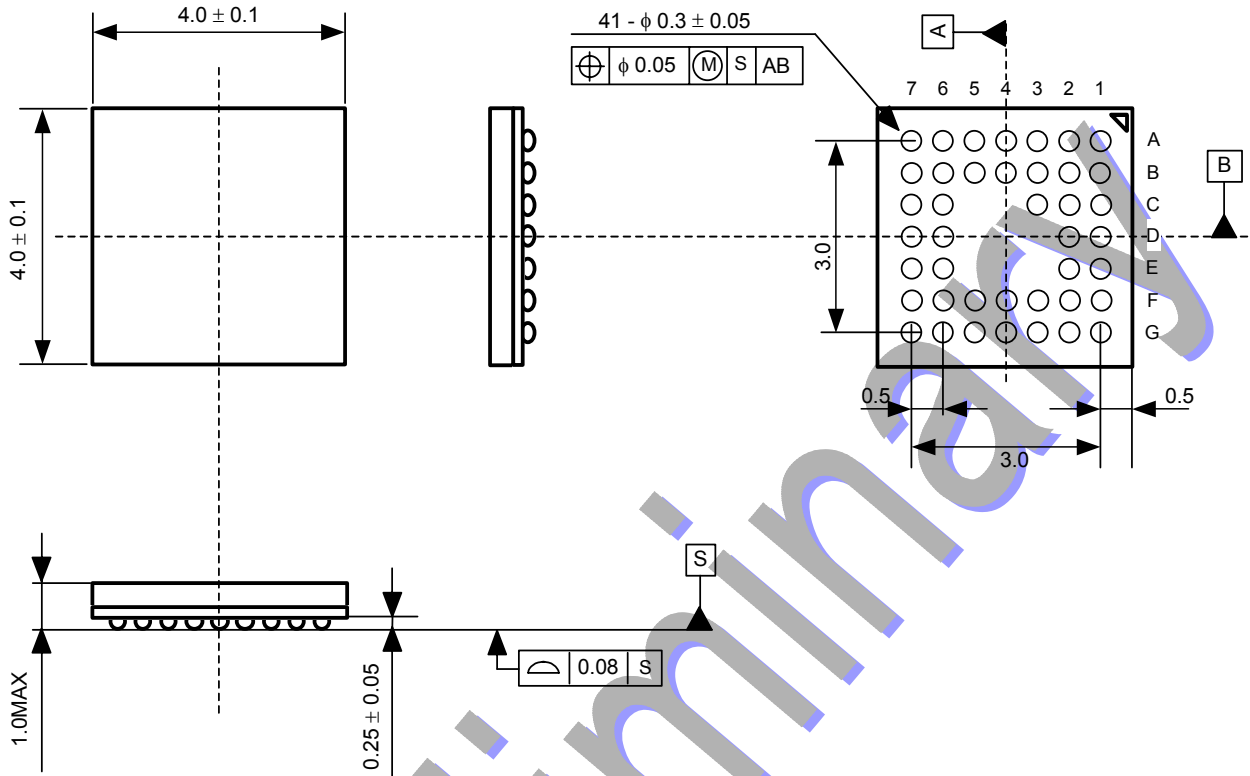

Package & Lead frame material

Package molding compound: Epoxy
Interposer material: BT resin
Solder ball material: SnAgCu

Package Marking Drawing

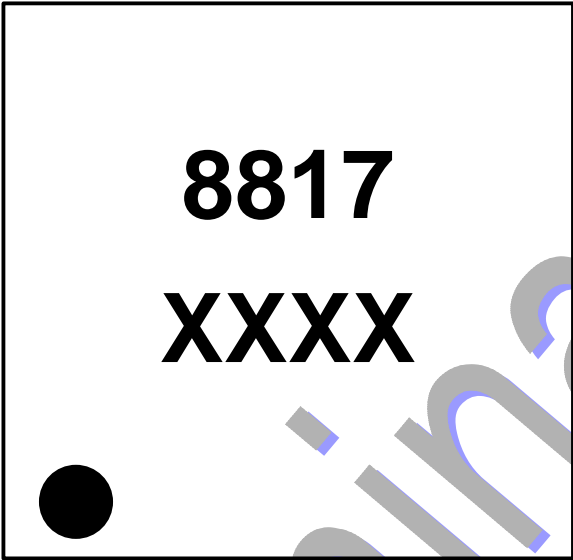

- a. Package Type: BGA
- b. Number of Pins: 41pins (Including INDEX pin)
- c. Product Number: 8817
- d. Control Code: XXXXX (4 digits)

Preliminary

liminary

IMPORTANT NOTICE

- These products and their specifications are subject to change without notice. Before considering any use or application, consult the Asahi Kasei Microsystems Co., Ltd. (AKM) sales office or authorized distributor concerning their current status.
- AKM assumes no liability for infringement of any patent, intellectual property, or other right in the application or use of any information contained herein.
- Any export of these products, or devices or systems containing them, may require an export license or other official approval under the law and regulations of the country of export pertaining to customs and tariffs, currency exchange, or strategic materials.
- AKM products are neither intended nor authorized for use as critical components in any safety, life support, or other hazard related device or system, and AKM assumes no responsibility relating to any such use, except with the express written consent of the Representative Director of AKM. As used here:
 - (a) A hazard related device or system is one designed or intended for life support or maintenance of safety or for applications in medicine, aerospace, unclear energy, or other fields, in which its failure to function or perform may reasonably be expected to result in loss of life or in significant injury or damage to person or property.
 - (b) A critical component is one whose failure to function or perform may reasonably be expected to result, whether directly or indirectly, in the loss of the safety or effectiveness of the device or system containing it, and which must therefore meet very high standards of performance and reliability.
- It is the responsibility of the buyer or distributor of an AKM product who distributes, disposes of, or otherwise places the product with a third party to notify that party in advance of the above content and conditions, and the buyer or distributor agrees to assume any and all responsibility and liability for and hold AKM harmless from any and all claims arising from the use of said product in the absence of such notification.