

GaAs IC 900 MHz High Dynamic Range Amplifier



AL106-84

Features

- +18 dBm Output Power
- +32 dBm Output IP3
- 1.8 dB Noise Figure
- Single +5 V Supply
- Input and Output Matched to 50 Ω
- Ideal for Cellular Applications

Description

The AL106-84 is a high dynamic range amplifier for 900 MHz applications. The amplifier has 19 dBm output power, high input intercept point (IIP3) of 18 dBm, low noise figure of 1.8 dB and operates from a single positive bias of +5 V. External resistor sets the amplifier drain current. No external matching elements are required. As a low noise driver amplifier it is ideally suited for 900 MHz wireless base station applications. The AL106-84 is encapsulated in SOIC-8 package with slug for improved heat dissipation and reliability.

SOIC-8 with Slug

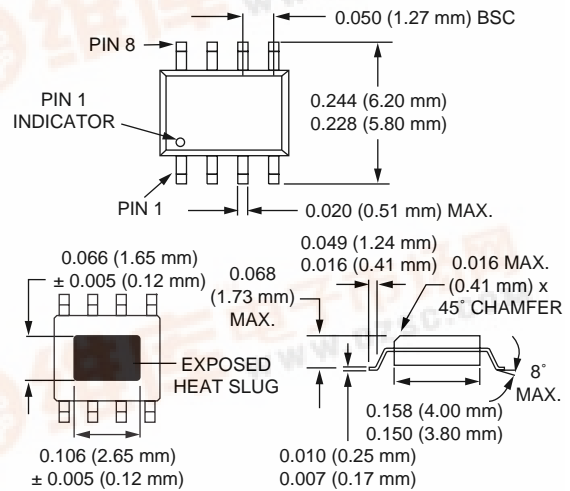

Electrical Specifications at 25°C

Parameter ¹	Condition	Frequency	Min.	Typ.	Max.	Unit
Small Signal Gain		800-960 MHz	13	14		dB
Input P _{-1dB}		900 MHz	5.5	7		dB
Input IIP3	P _{IN} = -5 dBm	900 MHz	17.5	18.5		dBm
Noise Figure		800-960 MHz		1.8	2.4	dB
Reverse Isolation		800-960 MHz		22		dB
Input VSWR		800-960 MHz		1.5:1		
Output VSWR		800-900 MHz		1.5:1		

1. Test condition V_D = +5 V, I_D = 80 mA.



Typical Performance Data at 25°C

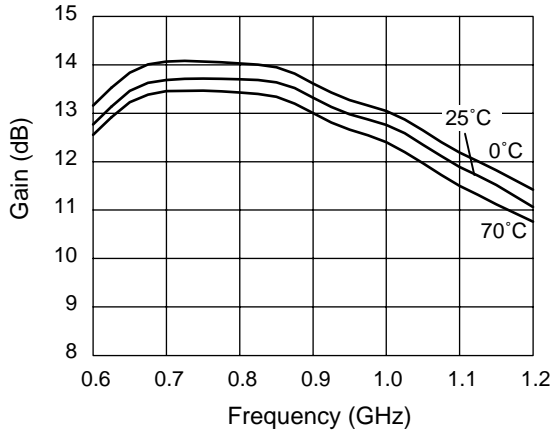

Gain vs. Frequency Over Temperature

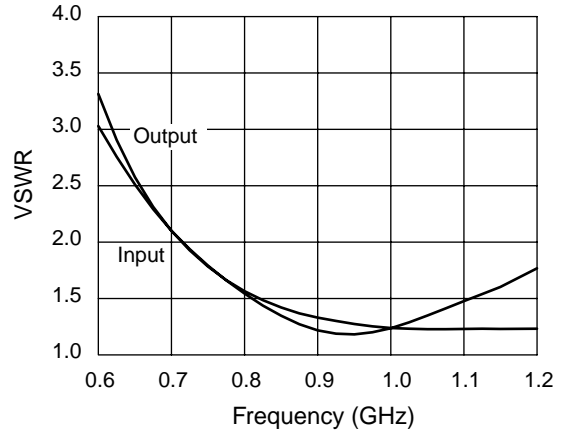

Input and Output VSWR vs. Frequency

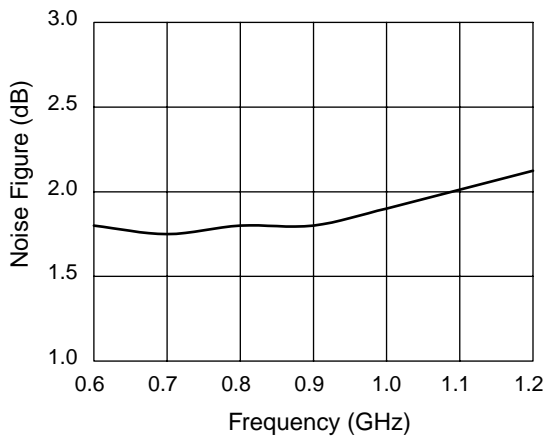

Noise Figure vs. Frequency

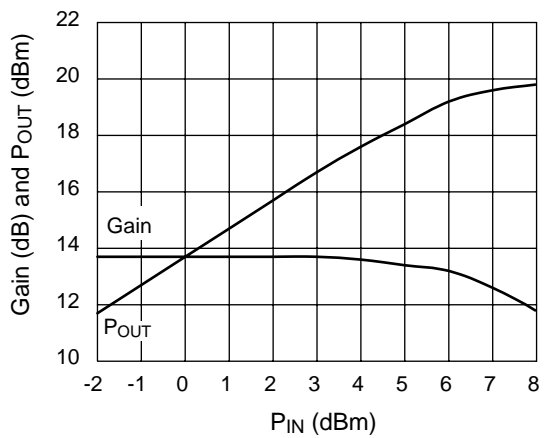

P_{OUT} and Gain vs. P_{IN} 900 MHz

Pin Out

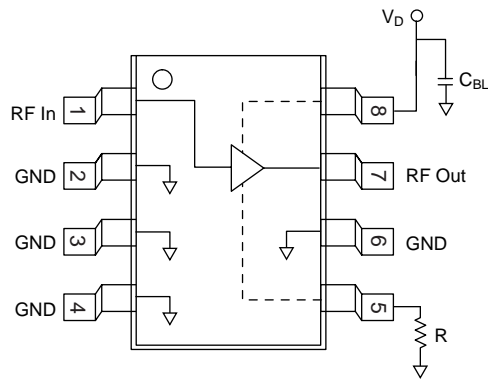

Power Supply and Current Settings

V_D of +5 V is fed to pin 8. A 200 pF bypass capacitor should be placed as close as possible to the lead. The current can be set 60–110 mA by changing the resistor connected to pin 5 at a distance of up to 5 mm away from the lead on FR4 substrate. Typical values for the resistor (R) are 8–18 Ω .

Pin Configuration

Terminal	Symbol	Function
1	RF In	RF input
2	GND	Ground
3	GND	Ground
4	GND	Ground
5	R	Current Set External Resistor
6	GND	Ground
7	RF Out	RF Output
8	V_D	+5 V Supply Through Bypass Cap

Absolute Maximum Ratings

Characteristic	Value
Drain Voltage (V_D)	7 V
Current (I_D)	150 mA
Input Power (P_{IN})	20 dBm
Operating Temperature (T_{OP})	-30 to +100°C
Storage Temperature (T_{ST})	-65 to +120°C