



# AMC393

## LOW OFFSET VOLTAGE DUAL COMPARATORS

### DESCRIPTION

The AMC393 series is designed containing two independent precision voltage comparators with low offset voltage of 2.0 mV typical. It can operate from a single power supply over a wide range from 5V to 30V.

Operation from split power supplies is also applicable and the low power supply current is independent of the magnitude of the power supply voltage.

The AMC393 series has the unique characteristic in that the input common-mode voltage range includes ground, even though it is operated from a single power supply voltage.

### FEATURES

- Wide supply voltage range
- Low supply current (typical 0.4 mA), independent of the magnitude of supply voltage
- Operated by either single supply or dual supplies
- Low input offset voltage (typical 2mV)
- Low input biasing current
- Input common-mode voltage range includes ground
- Pin assignment identical to earlier LM393 series.

### APPLICATIONS

- Limit Comparators
- Simple Analog to Digital Converters
- Pulse, Square Wave Generators
- Wide Range VCO
- MOS Clock Timers

### PACKAGE PIN OUT

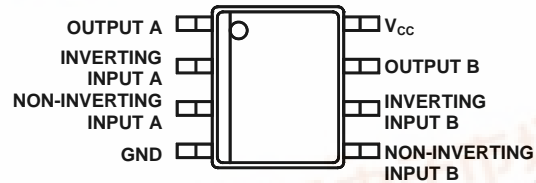

8-Pin Plastic S.O.I.C. (Top View)

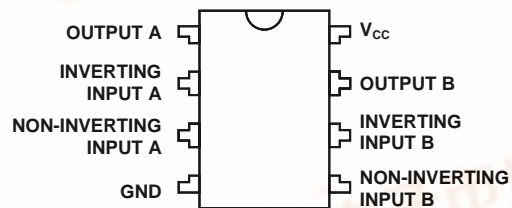

8-Pin Plastic DIP (Top View)

### ORDER INFORMATION

T <sub>A</sub> (°C)	<b>M</b>	Plastic DIP 8-pin	<b>DM</b>	Plastic SOIC 8-pin
	<b>0 to 70</b>	<b>AMC393MF</b>		<b>AMC393DMF</b>
Note: All surface-mount packages are available in Tape & Reel. Append the letter "T" to part number (i.e. AMC393DMT). The letter "F" is marked for Lead Free process.				

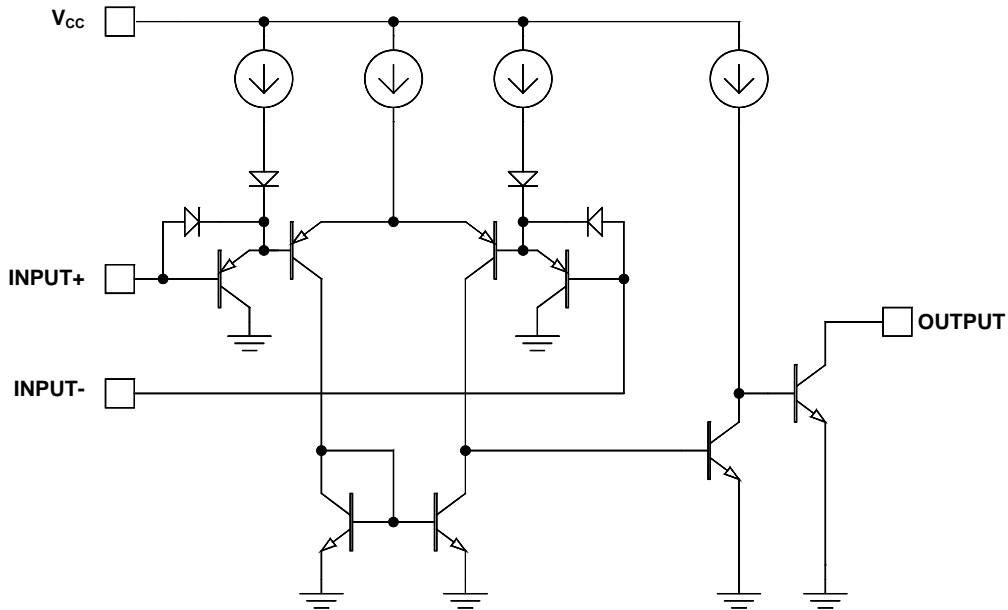

**SCHEMATIC DIAGRAM (each comparator)**

**ABSOLUTE MAXIMUM RATINGS (Note 1)**

Input Supply Voltage	32V
Input Voltage	-0.3V to 30V
Differential Input Voltage	32V
Operating Junction Temperature Range, $T_j$	150°C
Storage Temperature Range	-65°C to 150°C
Lead Temperature (soldering, 10 seconds)	260°C

Note 1: Exceeding these ratings could cause damage to the device. All voltages are with respect to Ground. Currents are positive into, negative out of the specified terminal.

**ELECTRICAL CHARACTERISTICS**

Unless otherwise specified, these specifications apply the operating at specified free-air temperatures and  $V_{CC} = 5V$ .

Parameter	Symbol	Test Conditions	AMC393			Units
			Min	Typ	Max	
Input Offset Voltage	$V_{IO}$	$T_A = 25^\circ C$ (Note 1)		2	5	mV
		$0^\circ C \leq T_A \leq 70^\circ C$			9	
Input Bias Current (Note 2)	$I_{IB}$	$V_{CM} = 0V$ , $V_{OUT} = 1.4V$	$T_A = 25^\circ C$	-25	-250	nA
			$0^\circ C \leq T_A \leq 70^\circ C$		-400	
Input Offset Current	$I_{IO}$	$V_{CM} = 0V$ , $V_{OUT} = 1.4V$	$T_A = 25^\circ C$	5	50	nA
			$0^\circ C \leq T_A \leq 70^\circ C$		150	
Input Common-mode Voltage Range (Note 3)	$V_{CM}$	$V_{CC} = 30V$	$T_A = 25^\circ C$	0	$V_{CC} - 1.5$	V
			$0^\circ C \leq T_A \leq 70^\circ C$	0	$V_{CC} - 2.0$	
Supply Current	$I_{CC}$	No load	$0^\circ C \leq T_A \leq 70^\circ C$	0.8	1.0	mA
		$V_{CC} = 30V$ , No load			2.5	
Low-level Output Voltage	$V_{OL}$	$V_{IN}^+ - V_{IN}^- = -1V$ , $I_{OL} \leq 4mA$	$T_A = 25^\circ C$	150	400	mV
			$0^\circ C \leq T_A \leq 70^\circ C$		700	
Low-level Output Current	$I_{OL}$	$V_{OUT} \leq 1.5V$ , $V_{IN}^+ - V_{IN}^- = -1V$ $T_A = 25^\circ C$	6			mA
High-level Output Current	$I_{OH}$	$V_{OUT} = 5V$ , $V_{IN}^+ - V_{IN}^- = 1V$	$T_A = 25^\circ C$	0.1		nA
			$0^\circ C \leq T_A \leq 70^\circ C$		1	$\mu A$
Large Signal Voltage Gain	$A_{VD}$	$V_{CC} = 15V$ , $V_{OUT} = 1.4V$ to $11.4V$ , $R_L \geq 15 k\Omega$ to $V_{CC}$	50	200		V/mV
Response Time (Note 4)		$R_L = 5.1K$ connected to $5V$ $T_A = 25^\circ C$		1.3		$\mu s$

Note 1:  $V_{OUT} \cong 1.4V$ ,  $R_S = 0\Omega$ , with  $V_{CC}$  from 5V to 30V; and over the full input common-mode range (0V to  $V_{CC} - 1.5V$ ) at  $25^\circ C$ .

Note 2: Due to PNP input stage, the direction of the input current is out of the IC. It is essentially constant, independent of the state of the output, so no loading change exists on the input lines.

Note 3: The input common-mode voltage of either input signal voltage should not be allowed to go negative by more than 0.3V (at  $25^\circ C$ ). The upper limit of the common-mode voltage range is  $V_{CC} - 1.5V$  (at  $25^\circ C$ ), but either or both inputs can go to 32V without damage, independent of the magnitude of  $V_{CC}$ .

Note 4: The response time specified is for a 100 mV input step with 5 mV overdrive.

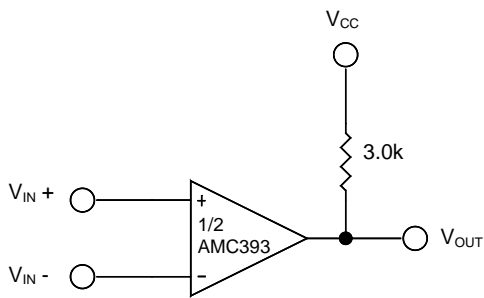
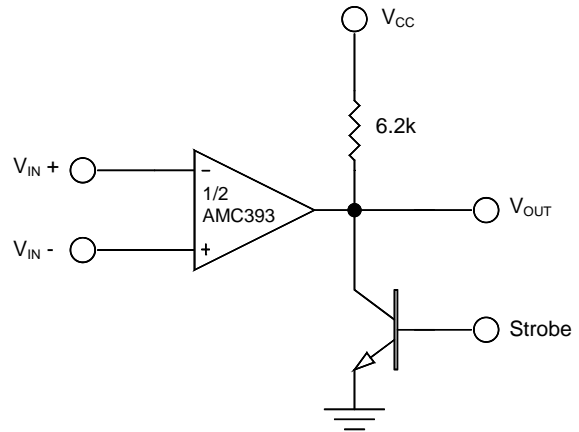
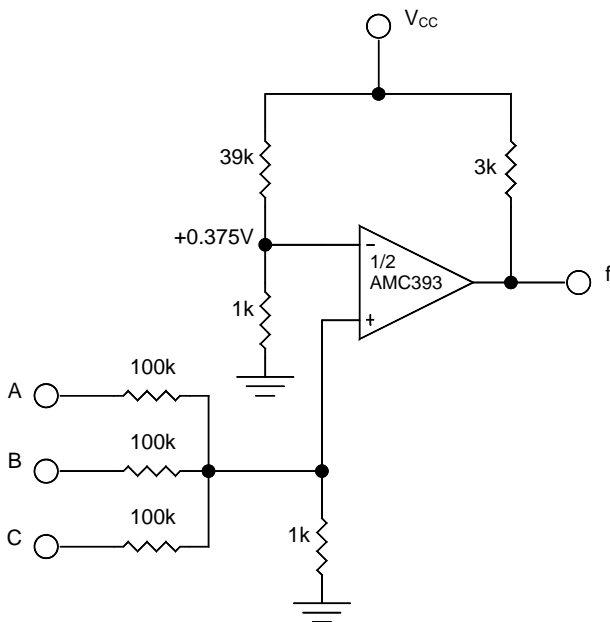
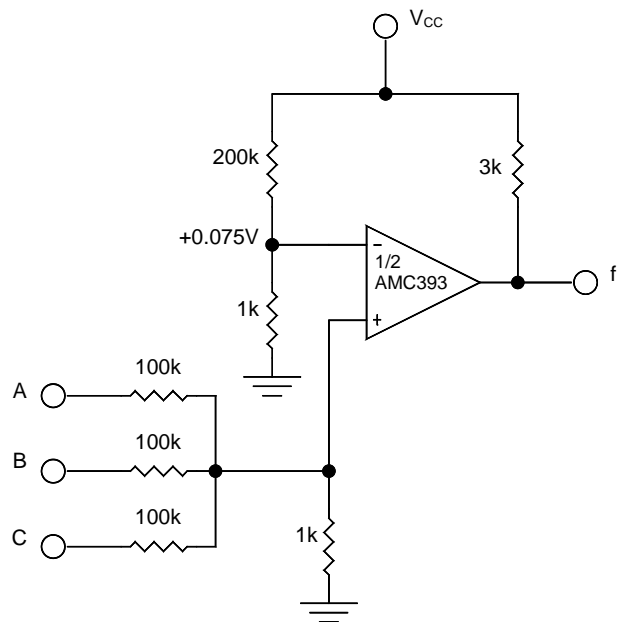
**APPLICATION INFORMATION**

**Basic Comparator**

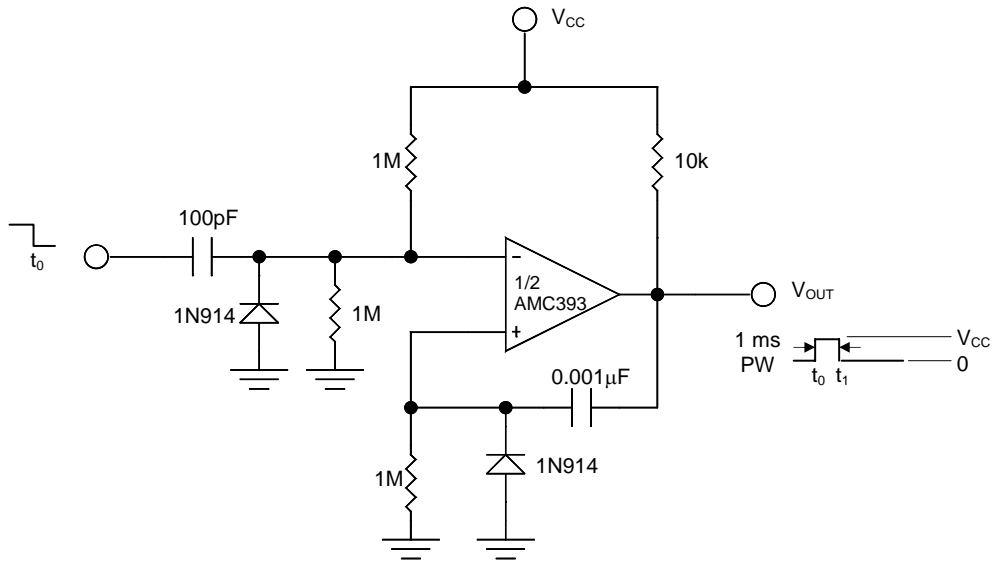
**Output Strobing**

**AND Gate**

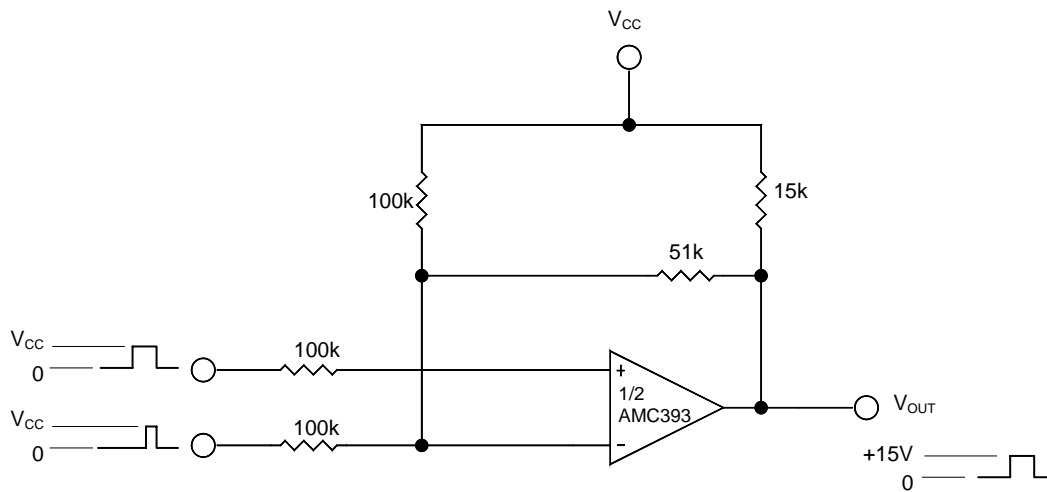
**OR Gate**

**APPLICATION INFORMATION (continued)**



**One Shot Multivibrator**



**Bi-Stable Multivibrator**

**APPLICATION INFORMATION (continued)**

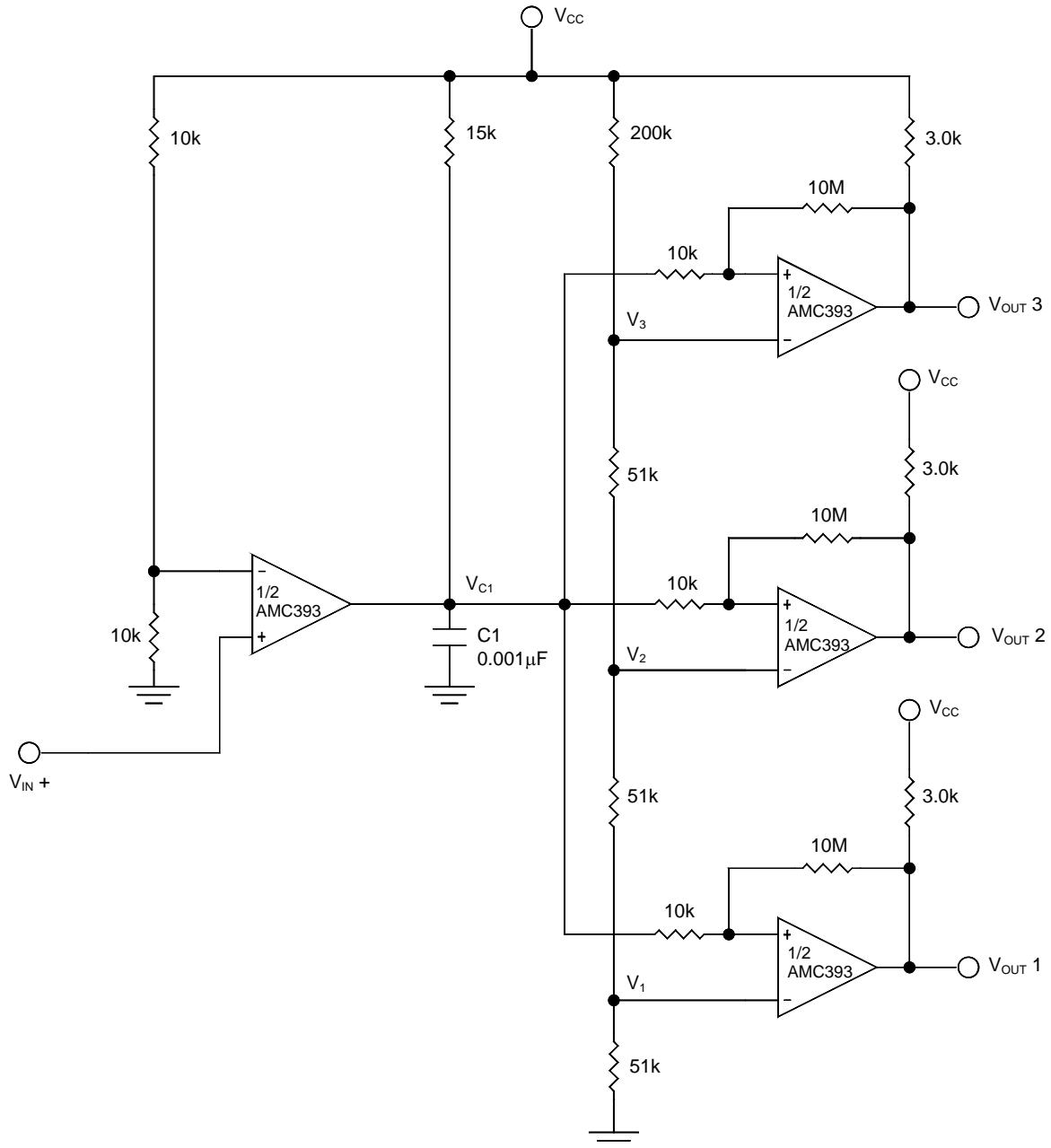

**Time Delay Generator**

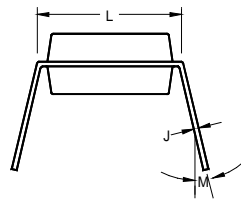
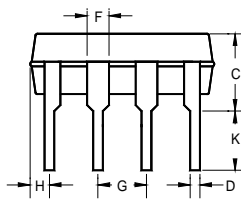
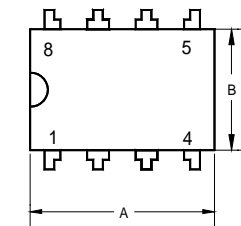
**PACKAGE**
**8-Pin Plastic DIP**

	INCHES			MILLIMETERS		
	MIN	TYP	MAX	MIN	TYP	MAX
A	0.355	0.365	0.400	9.02	9.27	10.16
B	0.240	0.250	0.280	6.10	6.35	7.11
C	-	-	0.210	-	-	5.33
D	-	0.018	-	-	0.46	-
F	-	0.060	-	-	1.52	-
G	-	0.100	-	-	2.54	-
H	0.050	-	0.090	1.27	-	2.29
J	0.008	-	0.015	0.20	-	0.38
K	0.115	0.130	0.150	2.92	3.30	3.81
L	0.300 BSC.			7.62 BSC.		
M	-	7°	15°	-	7°	15°

Note: For 8-pin Plastic package, 60 units per tube

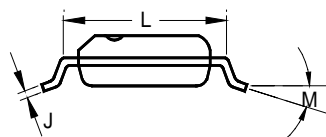
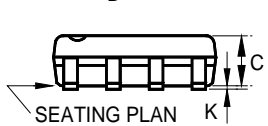
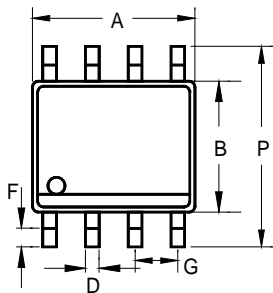
**8-Pin Plastic S.O.I.C.**

	INCHES			MILLIMETERS		
	MIN	TYP	MAX	MIN	TYP	MAX
A	0.183	-	0.202	4.65	-	5.13
B	0.144	-	0.163	3.66	-	4.14
C	0.068	-	0.074	1.35	-	1.88
D	0.010	-	0.020	0.25	-	0.51
F	0.015	-	0.035	0.38	-	0.89
G	0.050 BSC			1.27 BSC		
J	0.007	-	0.010	0.19	-	0.25
K	0.005	-	0.010	0.13	-	0.25
L	0.189	-	0.205	4.80	-	5.21
M	-	-	8°	-	-	8°
P	0.228	-	0.244	5.79	-	6.20

Note: For 8-pin S.O.I.C., 100 units per tube

**IMPORTANT NOTICE**

ADDtek reserves the right to make changes to its products or to discontinue any integrated circuit product or service without notice, and advises its customers to obtain the latest version of relevant information to verify, before placing orders, that the information being relied on is current.

A few applications using integrated circuit products may involve potential risks of death, personal injury, or severe property or environmental damage. ADDtek integrated circuit products are not designed, intended, authorized, or warranted to be suitable for use in life-support applications, devices or systems or other critical applications. Use of ADDtek products in such applications is understood to be fully at the risk of the customer. In order to minimize risks associated with the customer's applications, the customer should provide adequate design and operating safeguards.

ADDtek assumes no liability to customer product design or application support. ADDtek warrants the performance of its products to the specifications applicable at the time of sale.

---

**ADDtek Corp.**  
9F, No. 20, Sec. 3, Bade Rd., Taipei, Taiwan, 105  
TEL: 2-25700299  
FAX: 2-25700196

---