



# AMC7110/1/3/4

## WHITE/BLUE LED DRIVER FOR LI-ION BATTERY APPLICATION

### DESCRIPTION

The AMC7110 series is member of ADDM North Star White/Blue LED driver family. No external component is required. Especially good for use Li-ion battery powered LCD display's backlight white LEDs. The special circuit design provides over 90% efficiency in low noise.

Target end applications are color LCD display, such as mobile phone with color display, smart phone, PDA, etc.

### APPLICATIONS

- Small Size Color LCD Backlights
- Mobile Phone, Smart Phone Keypad Backlights

### OPTIONS

Device Name	LED Sink Current	Channel Number
AMC7110	20mA	3
AMC7111	20mA	4
AMC7113	15mA	3
AMC7114	15mA	4

### TYPICAL APPLICATION CIRCUIT

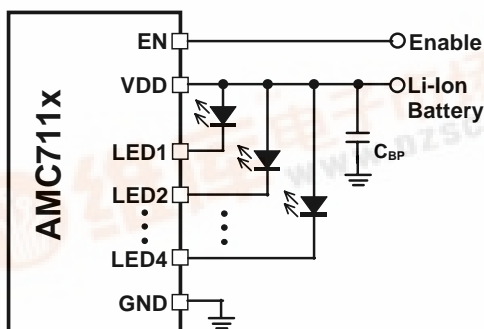

### FEATURES

- LED sink current 20mA and 15mA
- Individual current sink circuit for all LEDs outputs to prevent short / open circuit on LEDs.
- PTC LED current for luminosity compensation.
- 3 channels (SOT-26), 4 channels (MSOP-8) available.
- 90% efficiency
- Supply voltage range 2.7V ~ 6V
- 0.1uA standby current
- 2KV HBM ESD protection
- Advanced Bi-CMOS process.

### PACKAGE PIN OUT

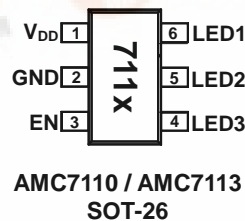

AMC7110 / AMC7113  
SOT-26

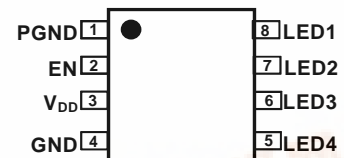

AMC7111 / AMC7114  
MSOP-8

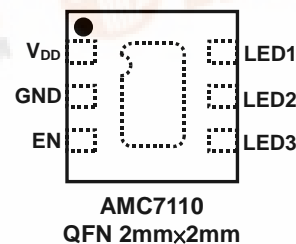

AMC7110  
QFN 2mmx2mm

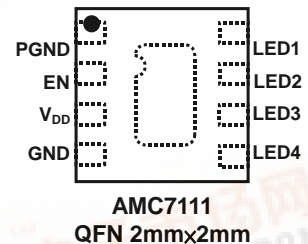

AMC7111  
QFN 2mmx2mm

### ORDER INFORMATION

I <sub>LED</sub> (mA)	DB	SOT-26	DN	MSOP-8	DJ	W	QFN 2x2	W	QFN 2x2
		6-pin		8-pin			6-pin		8-pin
18 ~ 22	AMC7110DBF		AMC7111DNF		AMC7110DJ	AMC7110WF		AMC7111WF	
19 ~ 21	AMC7110ADBDF		AMC7111ADNF	-	-	-	-	-	-
13.5 ~ 16.5	AMC7113DBF		AMC7114DNF	-	-	-	-	-	-

Note: Surface-mount packages is available in Tape & Reel. Append "T" to part number (i.e., AMC7111DNFT).  
The letter "F" is marked for lead free process.



**ABSOLUTE MAXIMUM RATINGS** (Note)

Input Voltage, $V_{DD}$	-0.3V to 7V
Output Voltage, $V_{LEDn}$	-0.3V to 7V
Voltage at all other pins	-0.3V to 5.5V
Maximum Junction Temperature, $T_J$	150°C
Storage Temperature Range	-40°C to 150°C
Lead Temperature (soldering, 10 seconds)	260°C

Note:  
Exceeding these ratings could cause damage to the device. All voltages are with respect to Ground.  
Currents are positive into, negative out of the specified terminal.

**POWER DISSIPATION TABLE**

Package	$\theta_{JA}$ (°C/W)	Derating factor (mW/°C) $T_A \geq 25^\circ\text{C}$	$T_A \leq 25^\circ\text{C}$ Power rating (mW)	$T_A = 70^\circ\text{C}$ Power rating (mW)	$T_A = 85^\circ\text{C}$ Power rating (mW)
DB	220	4.5	568	363	295
DJ	220	4.5	568	363	295
DN	180	5.56	695	444	361
W	76.5	13.1	1634	1045	849

Note :

Junction Temperature Calculation:  $T_J = T_A + (P_D \times \theta_{JA})$ .

$P_D$ : Power Dissipation,  $T_A$ : Ambient temperature,  $\theta_{JA}$ : Thermal Resistance-Junction to Ambient

The  $\theta_{JA}$  numbers are guidelines for the thermal performance of the device/PC-board system.

All of the above assume no ambient airflow.

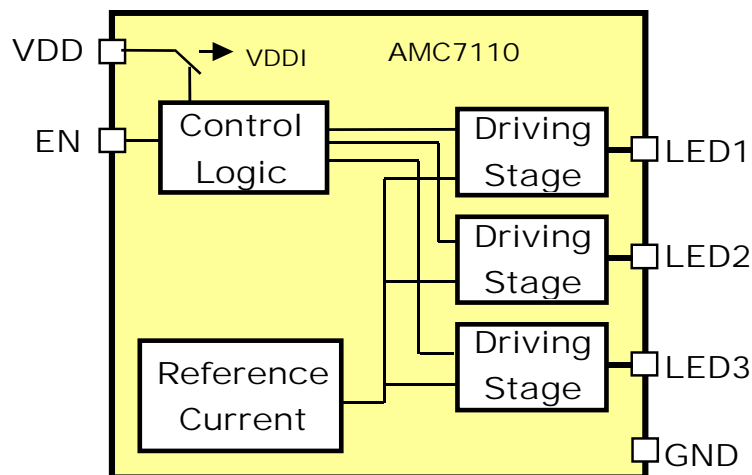
**BLOCK DIAGRAM**

**PIN DESCRIPTION**

Pin Name	Pin Function
LED1 ~ LED3/4	Output pins; connect to LED's cathode.
EN	Enable control pin. Pulling this pin high will enable the device. Pulling this pin to GND will disable the device.
V <sub>DD</sub>	Power supply
GND	Ground
PGND	Power ground

**RECOMMENDED OPERATING CONDITIONS**

Parameter	Symbol	Min	Typ	Max	Unit
Supply Voltage	V <sub>DD</sub>	2.7		6	V
Output Sink current	I <sub>LED</sub>			25	mA
Operating free-air temperature range	T <sub>a</sub>	-40		+85	°C

**ELECTRICAL CHARACTERISTICS**

V <sub>DD</sub> =3.7V, T <sub>A</sub> =25°C, No Load, Input: V <sub>IH</sub> =3.3V, V <sub>IL</sub> =GND. (Unless otherwise noted)								
Parameter	Symbol	Condition		Min	Typ	Max	Unit	Apply Pin
“Low” Input Voltage	V <sub>IL</sub>					0.4	V	EN
“High” Input Voltage	V <sub>IH</sub>			1.7			V	
“Low” Input Current	I <sub>IL</sub>			-5.0		+5.0	μA	
“High” Input Current	I <sub>IH</sub>			-5.0		+5.0	μA	
LED Dropout Voltage	V <sub>LEDL</sub>	AMC7110/1	Note		75	90	mV	LEDn
		AMC7113/4	Note		60	75		
LED Sink Current	I <sub>LED</sub>	AMC7110A AMC7111A	V <sub>DD</sub> =2.7V~6V V <sub>LEDL</sub> =0.15~3V	19	20	21	mA	
		AMC7110/1	V <sub>LEDL</sub> =0.15~3V	18	20	22		
			V <sub>DD</sub> =2.7V~6V V <sub>LEDL</sub> =0.15~3V	17	20	23		
		AMC7113/4		13.5	15	16.5		
LED Sink Current Deviation	ΔI <sub>LEDn</sub>	AMC7110A				±3	%	
						±5		
Supply Current	I <sub>DD</sub>				400	800	μA	V <sub>DD</sub>
Standby Supply Current	I <sub>DDSTBY</sub>				0.1		μA	

Note: LED Dropout Voltage: 90% × I<sub>LEDn</sub> @ V<sub>LEDL</sub>=150mV

**APPLICATION INFORMATION**
**Enable**

The EN pin enables and disables the device. Pulling the EN pin high will enable the device beginning sink current on LED pins. Pulling the EN pin to ground will shutdown the device reducing the I<sub>DD</sub> current to typical 0.1uA. This pin should not be left floating and need to be terminated.

**LED Brightness Control**

The LED sink current was fixed at 20mA or 15mA. Apply PWM signal to EN pin and control the duty that could control the LED brightness from 0% to maximum.

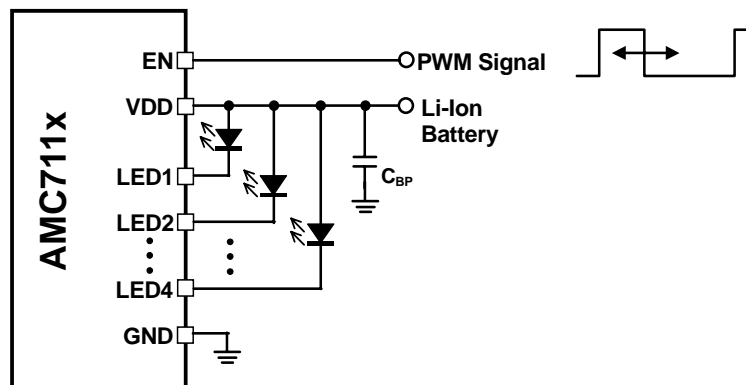
**Supply Voltage and Li-ion battery low warning**

AMC711X works with supply voltage range from 2.7V to 6V. The white/blue LED forward voltage is in the range of 2.9V to 3.5V at 20mA current. The supply voltage range and LED forward voltage (V<sub>f</sub>) should be set to fully utilize Li-ion battery energy. For example, the maximum white LED forward voltage limit at 3.2V (@ 20mA) when Li-ion battery discharge reaches 3.275V (normally around 1% ~ 3% power left in the battery). When Li-ion battery voltage is lower than the presetted low level, the LED current(brightness) will start to decrease.

**Efficiency**

The ACR (Advanced Current Regulator) architecture offers ultra low output dropout that significantly improves the efficiency compared to Inductive Boost type or Capacitor Charge Pump type LED driver. The system efficiency, defined as the ratio between the LEDs power and the input supplied power, is:

$$\text{Efficiency} = (V_{f1} \times I_{LED1} + V_{f2} \times I_{LED2} + V_{f3} \times I_{LED3} + V_{f4} \times I_{LED4}) / (V_{DD} \times I_{DD})$$

Where, V<sub>f</sub> is the forward voltage of LED.

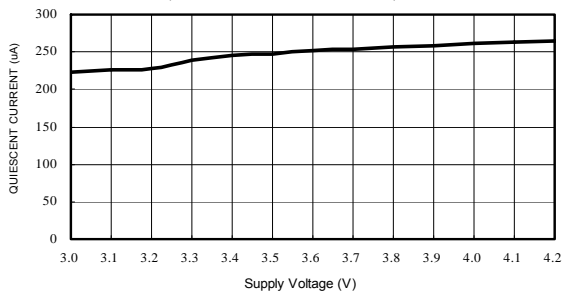
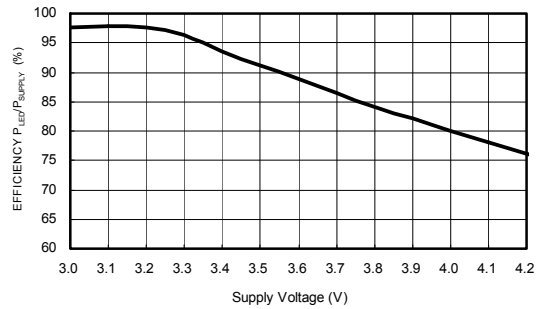
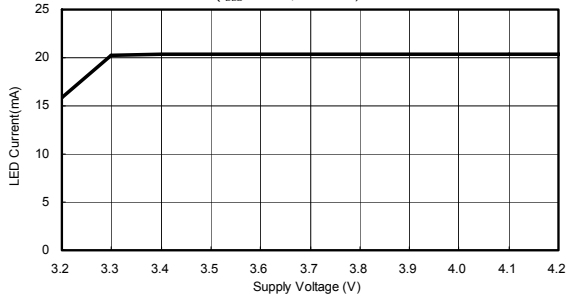
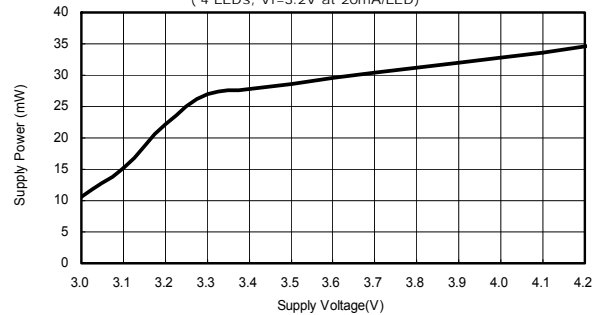
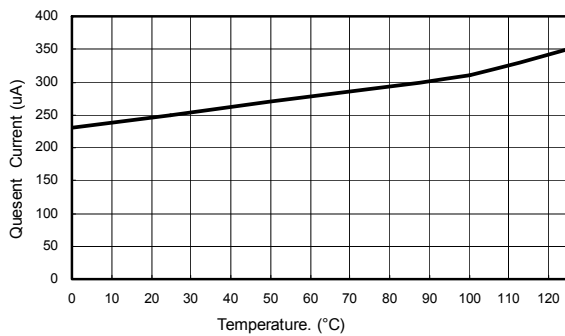
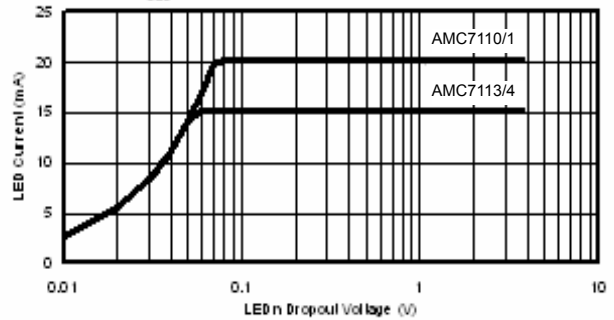
**CHARACTERIZATION CURVES**
**QUIESCENT CURRENT vs. SUPPLY VOLTAGE**  
 ( 4 LEDs, Vf=3.2V at 20mA/LED)

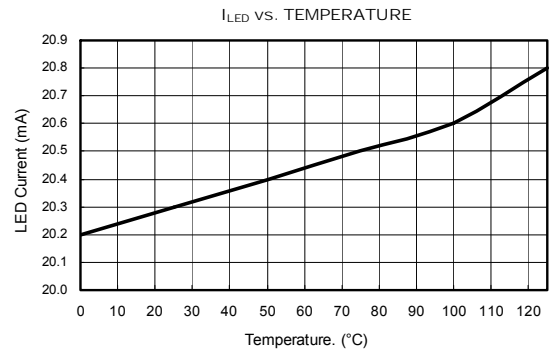
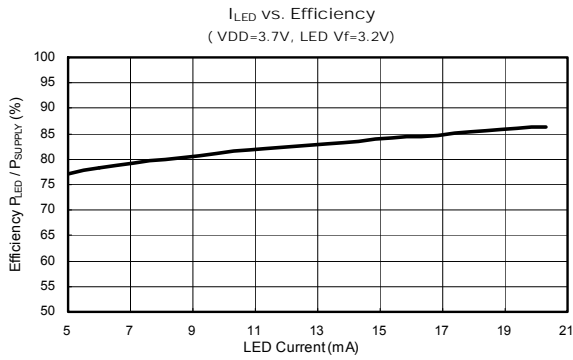
**EFFICIENCY vs. SUPPLY VOLTAGE**  
 ( 4 LEDs, Vf=3.2V at 20mA/LED)

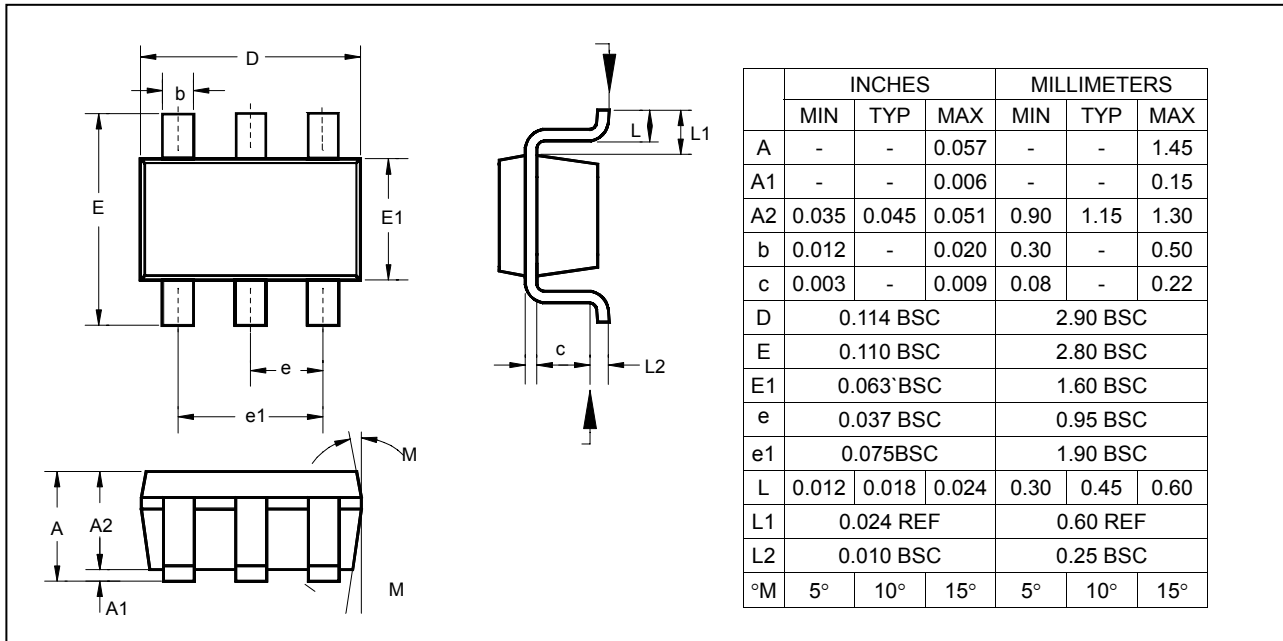
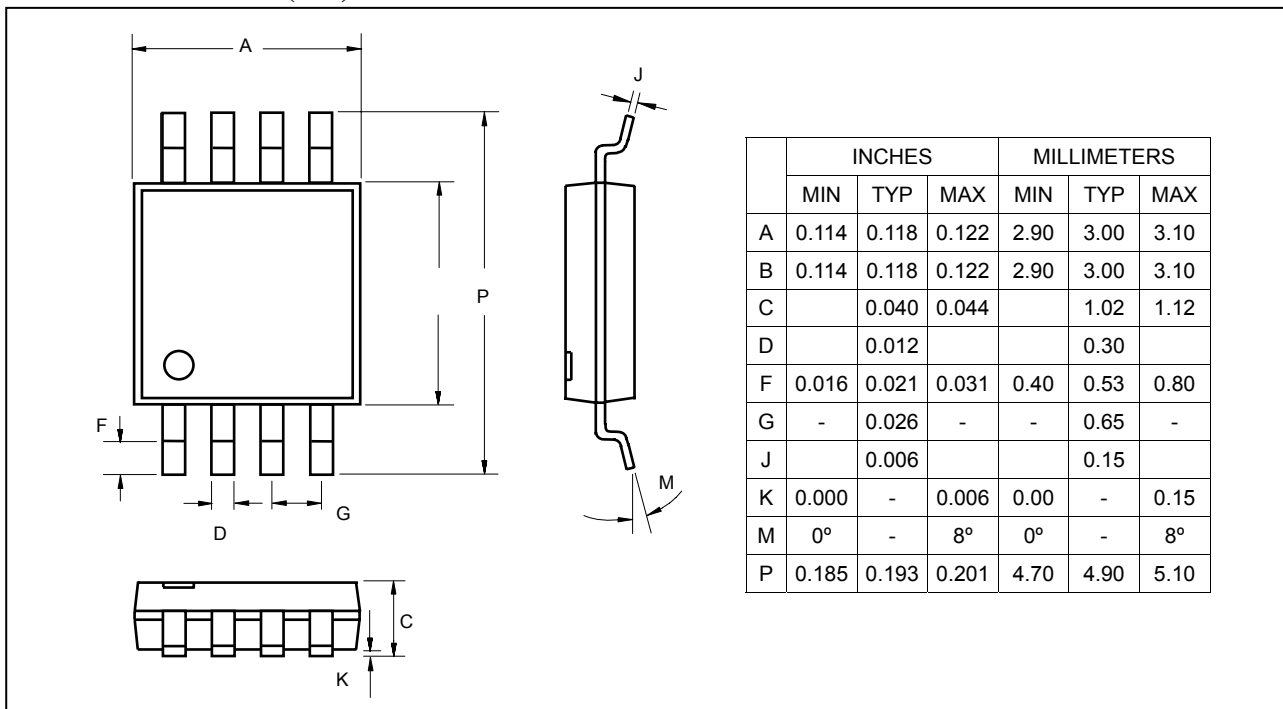
**I<sub>LED</sub> vs. SUPPLY VOLTAGE**  
 (I<sub>LED</sub>=20mA, Vf=3.2V)

**POWER IN vs. SUPPLY VOLTAGE**  
 ( 4 LEDs, Vf=3.2V at 20mA/LED)

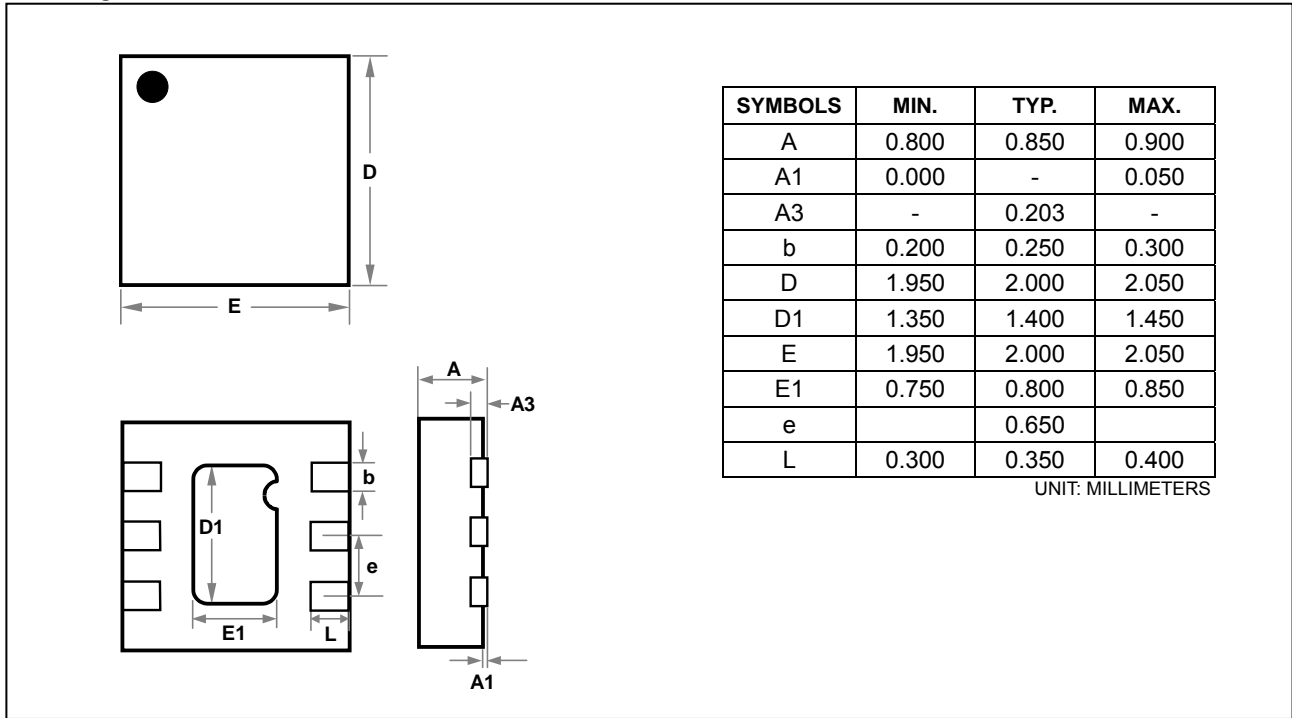
**QUIESCENT CURRENT vs TEMPERATURE**

**I<sub>LED</sub> vs. LEDn DROPOUT VOLTAGE**



**PACKAGE**
**Surface Mount SOT-26 (DB)**

**8-Pin Plastic MSOP (DN)**

6-Pin QFN 2mmx2mm

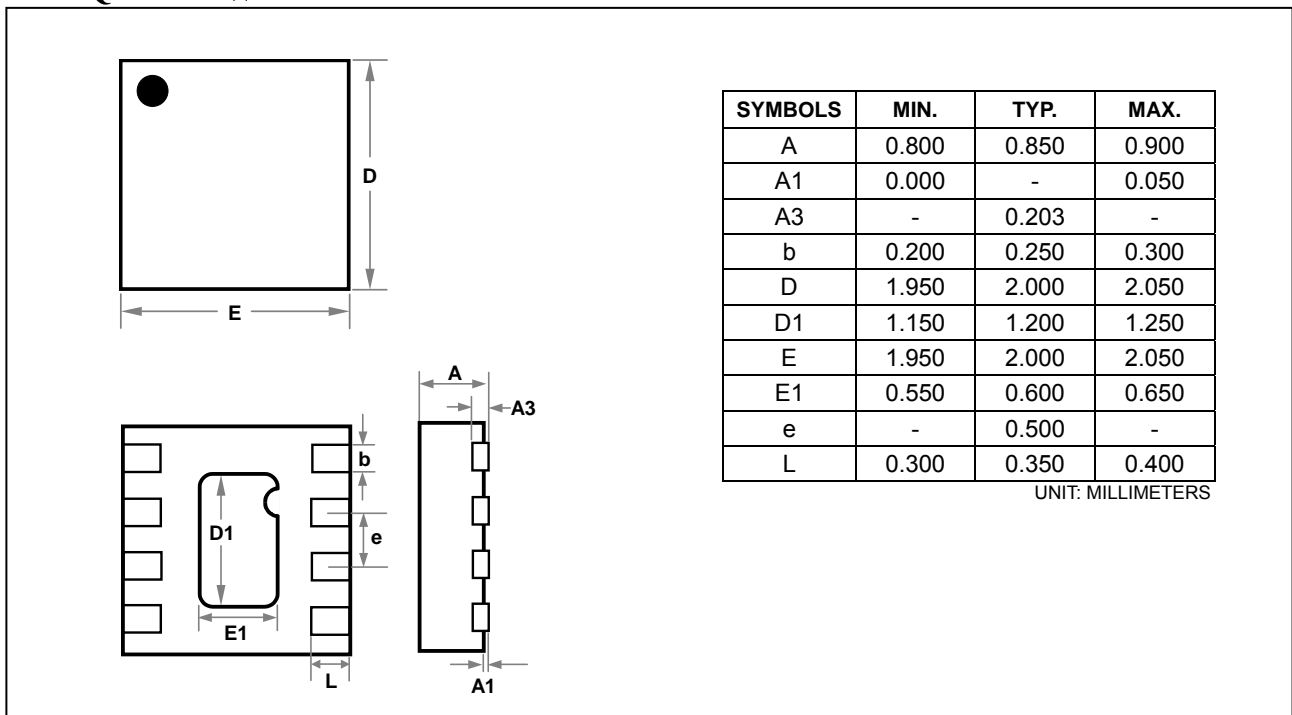

8-Pin QFN 2mmx2mm



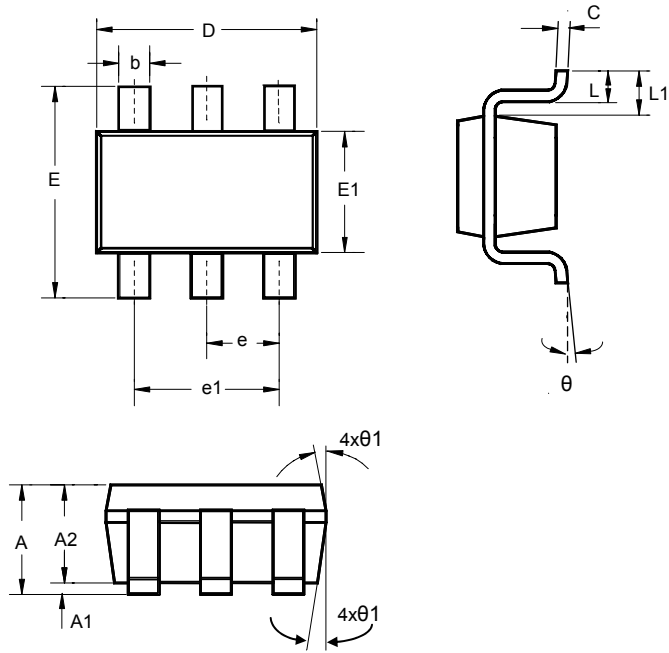

**Surface Mount TSOT-26**

SYMBOLS	MILLIMETERS		
	MIN	TYP	MAX
A	---	---	1.00
A1	0.00	0.05	0.10
A2	0.84	0.87	0.90
b	0.35	0.40	0.50
C	0.10	0.125	0.15
D	2.70	2.90	3.10
E	2.60	2.80	3.00
E1	1.40	1.60	1.80
e	---	0.95	---
e1	---	1.90	---
L	0.30	0.40	0.60
L1	0.5	0.6	0.7
$\theta$	0°	4°	8°
$\theta1$	4°	10°	12°

**IMPORTANT NOTICE**

ADDtek reserves the right to make changes to its products or to discontinue any integrated circuit product or service without notice, and advises its customers to obtain the latest version of relevant information to verify, before placing orders, that the information being relied on is current.

A few applications using integrated circuit products may involve potential risks of death, personal injury, or severe property or environmental damage. ADDtek integrated circuit products are not designed, intended, authorized, or warranted to be suitable for use in life-support applications, devices or systems or other critical applications. Use of ADDtek products in such applications is understood to be fully at the risk of the customer. In order to minimize risks associated with the customer's applications, the customer should provide adequate design and operating safeguards.

ADDtek assumes no liability to customer product design or application support. ADDtek warrants the performance of its products to the specifications applicable at the time of sale.

---

**ADDtek Corp.**

9F, No. 20, Sec. 3, Bade Rd., Taipei, Taiwan, 105

TEL: 2-25700299

FAX: 2-25700196

---