

AMMC-6345

20 – 45 GHz Driver Amplifier

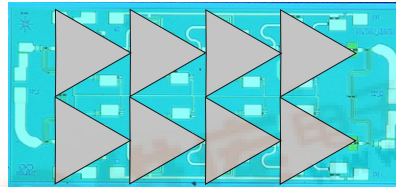

Data Sheet



Chip Size: 2500 x 1150 μm (100 x 69 mils)
 Chip Size Tolerance: $\pm 10\mu\text{m}$ (± 0.4 mils)
 Chip Thickness: $100 \pm 10\mu\text{m}$ (4 ± 0.4 mils)
 Pad Dimensions: $100 \times 100 \mu\text{m}$ (4 ± 0.4 mils)

Description

The AMMC-6345 MMIC is a broadband medium power amplifier designed for use in driving stage for transmitters that operate in various frequency bands between 20GHz and 45GHz. It can be used as a driver stage for the AMMC-6425, 6430 and 6440 (18-27GHz, 25-32GHz and 37-42GHz) 1W MMIC power amplifiers when linear operation is required. At 40GHz, it provides 24dBm of output power (P-1dB), 20dB of gain, and a 32 dBm output third order intercept (OIP3). The device has input and output matching circuitry for use in 50 Ω environments. The AMMC-6345 integrates a temperature compensated RF power detection circuit that enables power detection of 0.8V/W at 40GHz. The device operates on 5V for current supply (negative voltage only needed for Vg). It is fabricated in a PHEMT process for exceptional power and gain performance. For improved reliability and moisture protection, the die is passivated at the active areas.

Features

- Wide frequency range: 20 - 45 GHz
- High gain: 20 dB
- Power: @40 GHz, P-1dB=24 dBm
- Highly linear: OIP3=32dBm
- Integrated RF power detector
- 5.0 Volt, -0.55 Volt, 480mA operation

Applications

- Microwave Radio systems
- Satellite VSAT and DBS systems
- LMDS & Pt-Pt mmW Long Haul
- 802.16 & 802.20 WiMax BWA
- WLL and MMDS loops
- Commercial grade military
- Can be driver amplifier for the AMMC-64xx power amplifiers

AMMC-6345 Absolute Maximum Ratings^[1]

Symbol	Parameters/Conditions	Units	Min.	Max.
V _d	Positive Drain Voltage	V		7
V _g	Gate Supply Voltage	V	-3	0.5
I _d	Drain Current	mA		700
P _{in}	CW Input Power	dBm		23
T _{ch}	Operating Channel Temp.	°C		+150
T _{stg}	Storage Case Temp.	°C	-65	+150
T _{max}	Maximum Assembly Temp (60 sec max)	°C		+300

Note:

1. Operation in excess of any one of these conditions may result in permanent damage to this device.

NOTE: THESE DEVICES ARE ESD SENSITIVE. THE FOLLOWING PRECAUTIONS ARE STRONGLY RECOMMENDED. ENSURE THAT AN ESD APPROVED CARRIER IS USED WHEN DICE ARE TRANSPORTED FROM ONE DESTINATION TO ANOTHER. PERSONAL GROUNDING IS TO BE WORN AT ALL TIMES WHEN HANDLING THESE DEVICES



AMMC-6345 DC Specifications/Physical Properties [1]

Symbol	Parameters and Test Conditions	Units	Min.	Typ.	Max.
I _d	Drain Supply Current (under any RF power drive and temperature) (V _d =5.0V, V _g set for I _d typical)	mA		480	600
V _g	Gate Supply Operating Voltage I _{d(Q)} = 480mA	V	-0.75	-0.55	-0.4
V _p	Pinch-off voltage (V _{dd} =2.5V, I _{ds} =20mA)	V	-2.5	-1.2	-0.9
θ _{ch-b}	Thermal Resistance [2] Backside temperature, T _b =25°C	°C/W		8.2	

Notes:

1. Ambient operational temperature T_A=25°C unless otherwise noted.
2. Channel-to-backside Thermal Resistance (θ_{ch-b}) = 9.0°C/W at T_{channel} (T_c) = 70°C as measured using infrared microscopy. Thermal Resistance at backside temperature (T_b) = 25°C calculated from measured data.

AMMC-6345 RF Specifications [3, 4, 5] (T_A = 25°C, V_d=5V, I_{d(Q)}=480 mA, Z₀=50 Ω)

Symbol	Parameters and Test Conditions	Units	Minimum	Typical	Maximum	Sigma
Gain	Small-signal Gain ^[4]	dB	18			0.28
P _{-1dB}	Output Power at 1dB Gain Compression	dBm	22.5	24		0.20
P _{-3dB}	Output Power at 3dB Gain Compression	dBm		25		0.17
OIP3	Third Order Intercept Point; Δf=100MHz; Pin=-20dBm	dBm		32		0.8
RL _{in}	Input Return Loss ^[4]	dB		-17		0.92
RL _{out}	Output Return Loss ^[4]	dB		-13		0.63
Isolation	Min. Reverse Isolation	dB		-40		1.30

Notes:

3. Small/Large -signal data measured in wafer form T_A = 25°C.
4. 100% on-wafer RF test is done at frequency = 25, 30, and 38 GHz. Statistics based on 1500 part sample
5. Specifications are derived from measurements in a 50 Ω test environment. Aspects of the amplifier performance may be improved over a more narrow bandwidth by application of additional conjugate, linearity, or power matching.

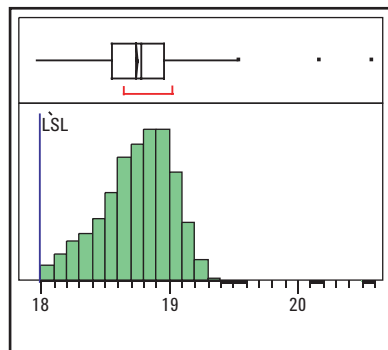

Gain at 30 GHz

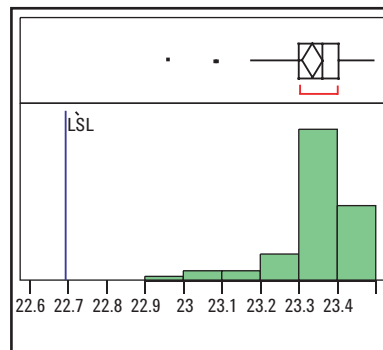

P-1dB at 30 GHz

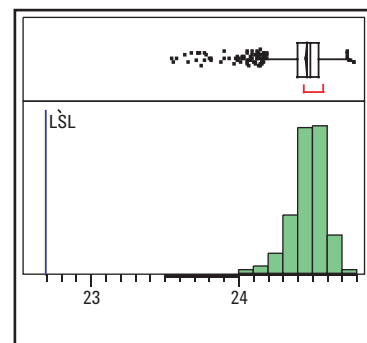

P-1dB at 38 GHz

Typical distribution of Small Signal Gain and Output Power @P-1dB. Based on 1500 part sampled over several production lots.

AMMC-6345 Typical Performances ($T_A = 25^\circ\text{C}$, $V_d = 5.0\text{ V}$, $I_D = 480\text{ mA}$, $Z_{in} = Z_{out} = 50\ \Omega$)

NOTE: These measurements are in a $50\ \Omega$ test environment. Aspects of the amplifier performance may be improved over a more narrow bandwidth by application of additional conjugate, linearity, or power matching.

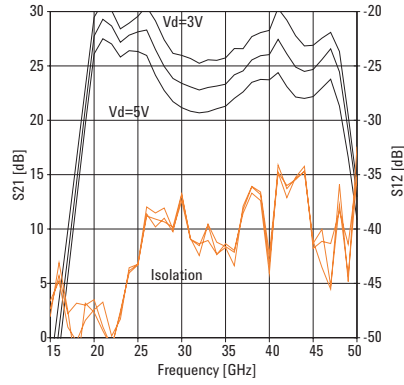

Figure 1. Typical Gain and Reverse Isolation at $V_d = 3\text{V}$, 4V , and 5V

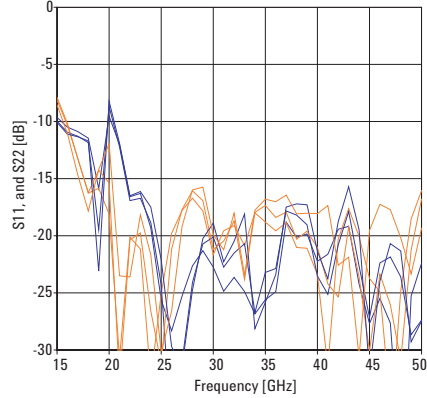

Figure 2. Typical Return Loss (Input and Output) at $V_d = 3\text{V}$, 4V , and 5V

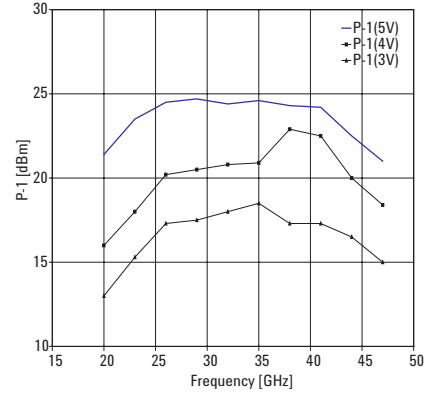

Figure 3. Typical Output Power (@P-1dB) and PAE at $V_d = 3\text{V}$, 4V , and 5V

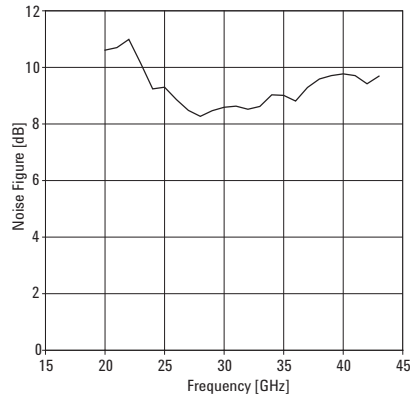

Figure 4. Typical Noise Figure

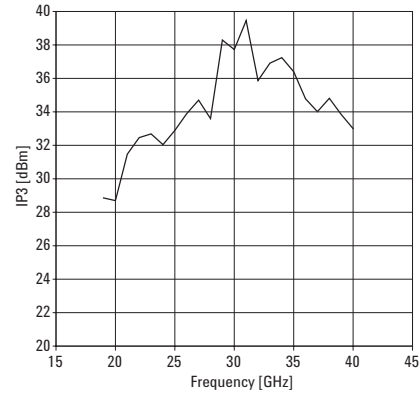

Figure 5. Typical Output 3rd Order Intercept Pt.

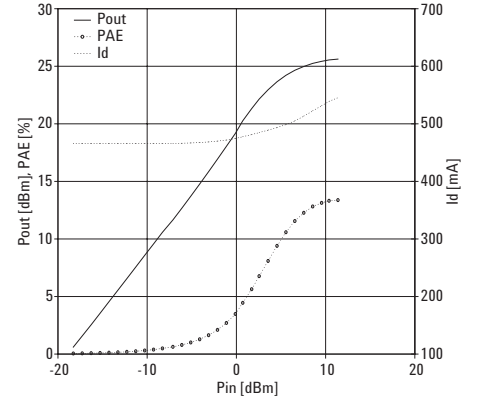

Figure 6. Typical Output Power, PAE, and Total Drain Current versus Input Power at 30GHz

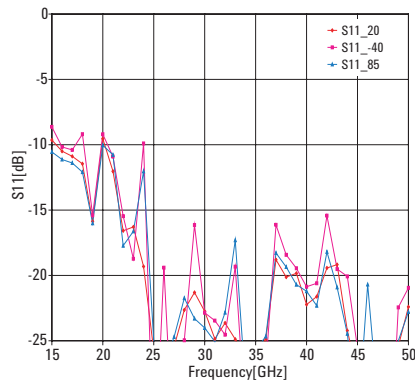

Figure 7. Typical S11 over temperature

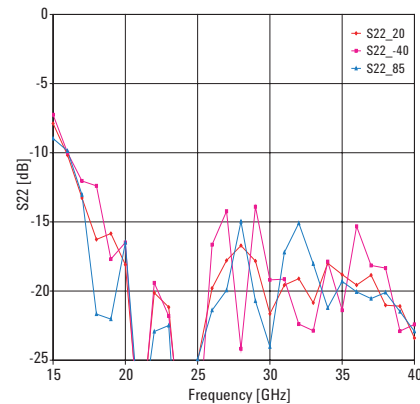

Figure 8. Typical S22 over temperature

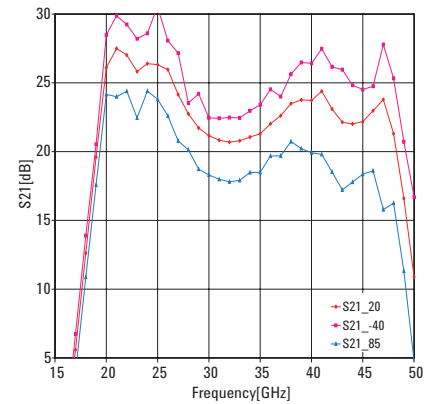

Figure 9. Typical Gain over temperature

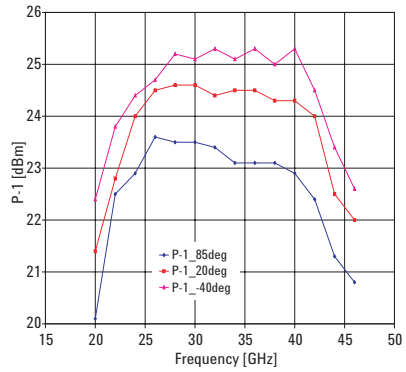

Figure 10. Typical One dB Compression over temperature

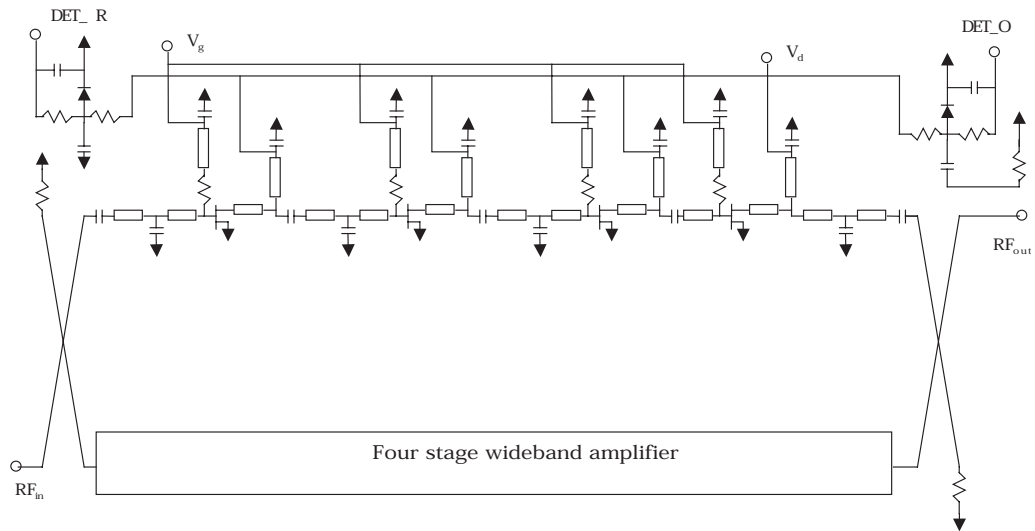

Figure 11. AMMC-6345 Schematic

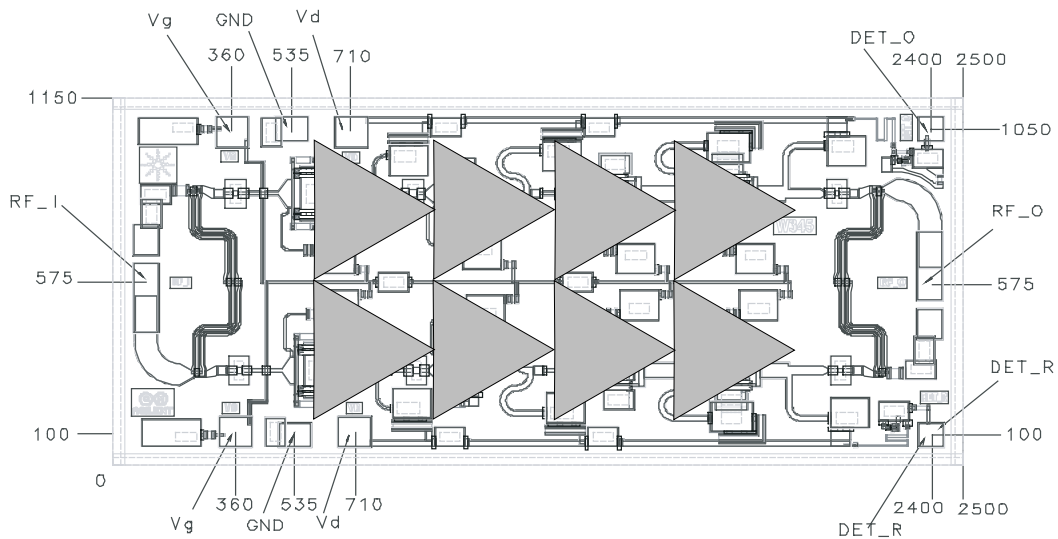

Figure 12. AMMC-6345 Bond pad locations

Typical Scattering Parameters [1], ($T_A = 25^\circ\text{C}$, $V_d = 5\text{ V}$, $I_D = 480\text{ mA}$, $Z_{in} = Z_{out} = 50\ \Omega$)

Freq GHz	S11			S21			S12			S22		
	dB	Mag	Phase	dB	Mag	Phase	dB	Mag	Phase	dB	Mag	Phase
1	-0.12	0.99	-19.15	-57.32	0.00	58.58	-84.82	5.74E-05	70.58	-0.08	0.99	-19.11
2	-0.36	0.96	-37.94	-55.89	0.00	177.71	-72.13	2.47E-04	12.23	-0.26	0.97	-38.22
3	-0.78	0.91	-56.52	-44.42	0.01	156.82	-73.64	2.08E-04	58.99	-0.68	0.92	-56.80
4	-1.24	0.87	-74.42	-44.66	0.01	18.13	-68.72	3.67E-04	-48.48	-0.90	0.90	-74.40
5	-1.83	0.81	-92.28	-41.91	0.01	-18.02	-64.72	5.81E-04	-6.62	-1.32	0.86	-92.91
6	-2.56	0.74	-109.82	-43.30	0.01	-74.83	-58.52	1.19E-03	-57.25	-1.83	0.81	-110.50
7	-3.48	0.67	-126.55	-46.99	0.00	-110.83	-59.25	1.09E-03	-84.92	-2.29	0.77	-127.65
8	-4.38	0.60	-142.45	-49.97	0.00	-167.43	-53.00	2.24E-03	-110.79	-2.68	0.73	-145.11
9	-5.32	0.54	-157.40	-44.20	0.01	-159.52	-50.89	2.86E-03	-135.83	-3.12	0.70	-163.32
10	-6.34	0.48	-171.66	-44.20	0.01	158.06	-49.45	3.37E-03	-155.71	-3.65	0.66	178.38
11	-7.32	0.43	175.24	-39.36	0.01	97.29	-49.30	3.43E-03	177.11	-4.23	0.61	159.66
12	-8.24	0.39	163.63	-32.87	0.02	28.85	-47.08	4.43E-03	165.36	-4.86	0.57	140.25
13	-9.06	0.35	152.38	-23.89	0.06	-33.55	-44.73	5.80E-03	129.26	-5.63	0.52	120.10
14	-9.65	0.33	141.86	-15.71	0.16	-84.27	-49.04	3.53E-03	119.12	-6.55	0.47	99.03
15	-10.03	0.32	132.41	-8.28	0.39	-133.47	-48.03	3.97E-03	126.80	-7.88	0.40	76.01
16	-10.37	0.30	119.00	-1.20	0.87	175.63	-43.10	7.00E-03	102.68	-9.68	0.33	53.09
17	-10.93	0.28	107.09	5.59	1.90	124.30	-47.51	4.21E-03	82.45	-12.19	0.25	28.87
18	-11.65	0.26	95.81	12.62	4.27	68.08	-53.58	2.09E-03	99.10	-15.60	0.17	5.21
19	-13.22	0.22	84.24	19.61	9.56	4.03	-46.83	4.55E-03	113.11	-19.86	0.10	-26.08
20	-12.80	0.23	94.60	26.10	20.19	-77.51	-47.66	4.14E-03	91.93	-25.66	0.05	-128.62
21	-10.44	0.30	68.43	27.50	23.72	-169.54	-49.36	3.40E-03	82.40	-20.66	0.09	120.00
22	-11.43	0.27	44.99	27.02	22.44	120.52	-50.90	2.85E-03	84.94	-21.88	0.08	103.50
23	-12.32	0.24	26.50	25.82	19.54	62.88	-47.58	4.18E-03	120.75	-17.37	0.14	57.61
24	-16.43	0.15	-13.72	26.40	20.90	11.34	-44.04	6.28E-03	118.67	-30.98	0.03	-23.98
25	-33.10	0.02	4.94	26.32	20.71	-44.56	-43.30	6.84E-03	97.04	-23.16	0.07	162.95
26	-18.10	0.12	116.73	25.96	19.87	-100.50	-38.62	1.17E-02	91.29	-13.22	0.22	130.94
27	-14.60	0.19	72.31	24.15	16.12	-150.08	-39.81	1.02E-02	79.49	-12.08	0.25	88.55
28	-14.58	0.19	36.54	22.74	13.71	169.71	-39.01	1.12E-02	66.21	-12.33	0.24	52.53
29	-15.53	0.17	16.63	21.72	12.19	131.45	-40.25	9.71E-03	52.18	-13.33	0.22	33.17
30	-17.91	0.13	8.16	21.16	11.43	90.73	-36.88	1.43E-02	39.00	-16.66	0.15	22.40
31	-19.92	0.10	17.96	20.83	11.01	54.44	-40.86	9.06E-03	27.57	-18.02	0.13	33.03
32	-19.18	0.11	10.21	20.68	10.82	17.84	-42.44	7.56E-03	23.47	-16.44	0.15	30.73
33	-24.05	0.06	-3.59	20.79	10.95	-18.83	-39.55	1.05E-02	34.21	-17.24	0.14	30.21
34	-21.13	0.09	8.05	21.06	11.30	-54.56	-41.21	8.70E-03	23.92	-14.43	0.19	13.79
35	-19.80	0.10	32.35	21.29	11.61	-95.07	-41.61	8.31E-03	24.14	-15.42	0.17	8.85
36	-23.53	0.07	32.05	22.02	12.61	-134.69	-42.14	7.82E-03	50.90	-18.45	0.12	-7.10
37	-17.56	0.13	5.55	22.61	13.50	-172.71	-38.23	1.23E-02	52.34	-13.77	0.20	3.88
38	-21.58	0.08	-52.01	23.49	14.95	141.12	-36.12	1.56E-02	17.88	-13.62	0.21	-41.65
39	-30.34	0.03	-114.67	23.76	15.42	95.64	-36.83	1.44E-02	6.44	-13.38	0.21	-69.60
40	-35.48	0.02	39.30	23.72	15.35	51.02	-43.22	6.91E-03	14.62	-20.67	0.09	-115.14
41	-17.21	0.14	143.54	24.39	16.57	-2.61	-34.82	1.81E-02	27.26	-14.67	0.18	178.89
42	-15.11	0.18	85.97	23.10	14.28	-50.90	-37.12	1.39E-02	23.49	-16.35	0.15	104.61
43	-12.25	0.24	53.08	22.14	12.80	-97.36	-35.25	1.73E-02	-1.27	-13.23	0.22	53.80
44	-12.99	0.22	17.98	22.01	12.61	-141.90	-34.23	1.94E-02	-13.24	-13.19	0.22	11.28
45	-15.86	0.16	13.27	22.18	12.86	168.99	-41.79	8.14E-03	-22.34	-18.56	0.12	-5.93
46	-23.96	0.06	15.35	22.97	14.08	113.52	-41.13	8.78E-03	-53.47	-32.37	0.02	-162.08
47	-24.63	0.06	102.35	23.78	15.45	42.51	-41.34	8.57E-03	-30.56	-19.03	0.11	168.70
48	-17.97	0.13	95.52	21.31	11.63	-33.83	-38.36	1.21E-02	50.51	-13.68	0.21	119.97
49	-14.20	0.19	46.11	16.60	6.76	-99.79	-41.40	8.51E-03	-16.54	-12.95	0.23	55.08
50	-14.67	0.18	22.54	10.89	3.50	-161.82	-35.04	1.77E-02	-0.97	-13.34	0.22	30.13

Note:

1. Data obtained from on-wafer measurements.

Typical Scattering Parameters [1], ($T_A = 25^\circ\text{C}$, $V_d = 4\text{ V}$, $I_D = 480\text{ mA}$, $Z_{in} = Z_{out} = 50\ \Omega$)

Freq GHz	S11			S21			S12			S22		
	dB	Mag	Phase	dB	Mag	Phase	dB	Mag	Phase	dB	Mag	Phase
1	-0.16	0.98	-19.19	-53.23	0.00	156.78	-68.83	3.62E-04	26.36	-0.08	0.99	-19.08
2	-0.39	0.96	-37.93	-67.95	0.00	55.37	-64.00	6.31E-04	-46.10	-0.26	0.97	-38.15
3	-0.78	0.91	-56.39	-40.54	0.01	131.73	-66.32	4.83E-04	20.50	-0.67	0.93	-56.74
4	-1.21	0.87	-74.41	-41.69	0.01	57.78	-69.07	3.52E-04	-130.05	-0.88	0.90	-74.37
5	-1.82	0.81	-92.14	-41.15	0.01	-19.49	-68.32	3.84E-04	-100.23	-1.31	0.86	-92.85
6	-2.56	0.74	-109.85	-41.77	0.01	-62.48	-65.80	5.13E-04	-99.25	-1.81	0.81	-110.47
7	-3.46	0.67	-126.58	-43.64	0.01	-133.57	-61.51	8.41E-04	-98.06	-2.28	0.77	-127.65
8	-4.41	0.60	-142.71	-56.23	0.00	-160.01	-55.12	1.75E-03	-107.65	-2.66	0.74	-145.13
9	-5.36	0.54	-157.57	-44.89	0.01	-148.14	-49.82	3.23E-03	-144.87	-3.08	0.70	-163.32
10	-6.34	0.48	-171.64	-41.33	0.01	164.06	-51.14	2.77E-03	-153.44	-3.66	0.66	178.32
11	-7.33	0.43	175.31	-37.05	0.01	100.59	-48.19	3.90E-03	171.91	-4.26	0.61	159.59
12	-8.29	0.39	163.66	-29.27	0.03	28.45	-45.53	5.29E-03	173.32	-4.89	0.57	140.42
13	-9.10	0.35	152.68	-21.03	0.09	-27.89	-45.00	5.62E-03	127.55	-5.70	0.52	120.37
14	-9.72	0.33	141.78	-13.45	0.21	-80.16	-48.38	3.81E-03	124.53	-6.66	0.46	99.20
15	-9.97	0.32	131.78	-6.07	0.50	-129.87	-46.59	4.68E-03	107.01	-8.03	0.40	76.86
16	-10.32	0.30	119.00	0.84	1.10	178.98	-44.78	5.77E-03	99.88	-9.85	0.32	54.59
17	-10.96	0.28	107.47	7.47	2.36	128.36	-49.02	3.54E-03	78.01	-12.37	0.24	30.81
18	-11.71	0.26	95.84	14.30	5.19	73.07	-50.33	3.04E-03	89.14	-15.82	0.16	7.87
19	-13.73	0.21	82.90	21.14	11.40	10.66	-48.40	3.80E-03	103.60	-20.31	0.10	-22.64
20	-13.44	0.21	101.63	27.75	24.40	-68.25	-47.42	4.25E-03	95.39	-24.25	0.06	-132.65
21	-10.17	0.31	73.51	29.29	29.14	-160.93	-46.73	4.61E-03	73.57	-17.32	0.14	120.11
22	-10.75	0.29	47.22	28.67	27.15	129.50	-49.84	3.22E-03	79.27	-19.85	0.10	96.63
23	-11.65	0.26	28.96	27.17	22.84	72.85	-48.29	3.85E-03	116.81	-15.29	0.17	58.23
24	-14.41	0.19	-12.94	27.83	24.63	25.32	-43.57	6.63E-03	111.65	-22.20	0.08	-12.94
25	-26.32	0.05	-49.37	28.13	25.51	-28.85	-43.25	6.88E-03	98.92	-27.47	0.04	-156.00
26	-17.59	0.13	144.74	28.31	26.02	-84.66	-38.80	1.15E-02	91.99	-13.18	0.22	146.66
27	-13.92	0.20	85.99	26.51	21.16	-136.32	-39.09	1.11E-02	75.56	-11.45	0.27	96.76
28	-13.53	0.21	44.86	24.96	17.69	-176.33	-39.34	1.08E-02	64.27	-11.51	0.27	55.30
29	-14.08	0.20	21.41	23.85	15.57	145.34	-39.82	1.02E-02	51.62	-12.15	0.25	33.35
30	-16.63	0.15	8.93	23.40	14.79	104.50	-36.76	1.45E-02	39.20	-15.64	0.17	14.37
31	-18.90	0.11	14.45	23.07	14.25	68.67	-40.95	8.97E-03	31.81	-18.45	0.12	25.83
32	-18.32	0.12	6.29	22.79	13.78	32.49	-41.36	8.55E-03	29.88	-16.78	0.14	27.77
33	-23.55	0.07	-19.09	23.02	14.15	-3.82	-41.06	8.85E-03	40.72	-18.01	0.13	28.28
34	-21.32	0.09	3.37	23.15	14.37	-39.05	-42.31	7.66E-03	23.74	-14.20	0.20	15.86
35	-20.70	0.09	39.68	23.32	14.66	-79.03	-41.70	8.23E-03	19.32	-15.46	0.17	12.48
36	-25.47	0.05	45.58	24.18	16.18	-117.44	-43.38	6.78E-03	45.45	-18.04	0.13	-10.74
37	-16.57	0.15	19.35	24.54	16.87	-154.34	-37.91	1.27E-02	48.15	-13.35	0.21	13.37
38	-18.72	0.12	-38.12	25.55	18.95	162.14	-36.08	1.57E-02	14.52	-12.05	0.25	-33.40
39	-24.40	0.06	-86.55	25.94	19.82	117.99	-36.60	1.48E-02	8.30	-11.11	0.28	-58.03
40	-34.49	0.02	-38.53	26.04	20.05	74.33	-42.30	7.67E-03	19.67	-16.29	0.15	-98.87
41	-16.04	0.16	176.52	27.45	23.57	21.73	-34.79	1.82E-02	31.11	-10.90	0.29	-152.87
42	-14.51	0.19	103.12	26.11	20.20	-29.49	-36.00	1.59E-02	19.97	-13.58	0.21	139.52
43	-10.71	0.29	62.82	24.89	17.57	-77.62	-35.46	1.69E-02	-8.94	-11.34	0.27	76.58
44	-11.02	0.28	24.70	24.50	16.78	-120.85	-34.68	1.85E-02	-14.35	-11.65	0.26	32.59
45	-13.86	0.20	16.77	24.68	17.13	-169.94	-41.32	8.59E-03	-10.57	-15.92	0.16	24.76
46	-21.24	0.09	-28.71	25.58	19.02	136.62	-40.03	9.97E-03	-46.31	-37.34	0.01	-5.22
47	-30.77	0.03	-132.19	26.58	21.32	69.26	-45.20	5.50E-03	-26.74	-26.86	0.05	-131.95
48	-18.22	0.12	137.35	24.46	16.71	-8.92	-37.76	1.29E-02	28.33	-14.49	0.19	146.63
49	-14.30	0.19	51.01	19.02	8.94	-75.39	-44.27	6.12E-03	-19.20	-13.28	0.22	60.47
50	-13.69	0.21	33.04	13.00	4.47	-134.58	-35.29	1.72E-02	4.22	-12.32	0.24	37.59

Note:

1. Data obtained from on-wafer measurements.

Typical Scattering Parameters [1], ($T_A = 25^\circ\text{C}$, $V_d = 3\text{ V}$, $I_D = 480\text{ mA}$, $Z_{in} = Z_{out} = 50\ \Omega$)

Freq GHz	S11			S21			S12			S22		
	dB	Mag	Phase	dB	Mag	Phase	dB	Mag	Phase	dB	Mag	Phase
1	-0.17	0.98	-19.23	-56.53	0.00	-171.93	-70.34	3.04E-04	-153.86	-0.08	0.99	-19.04
2	-0.38	0.96	-37.92	-51.18	0.00	-121.05	-70.16	3.11E-04	-53.76	-0.25	0.97	-38.12
3	-0.80	0.91	-56.53	-44.83	0.01	160.51	-77.47	1.34E-04	51.20	-0.68	0.93	-56.61
4	-1.24	0.87	-74.31	-38.86	0.01	30.95	-63.95	6.34E-04	-26.36	-0.88	0.90	-74.33
5	-1.83	0.81	-92.16	-42.87	0.01	-0.87	-64.81	5.75E-04	-27.92	-1.29	0.86	-92.83
6	-2.58	0.74	-109.70	-42.04	0.01	-82.73	-61.74	8.19E-04	-55.95	-1.79	0.81	-110.36
7	-3.45	0.67	-126.71	-47.50	0.00	-124.89	-59.13	1.10E-03	-96.04	-2.27	0.77	-127.57
8	-4.41	0.60	-142.79	-51.25	0.00	-125.67	-56.49	1.50E-03	-112.50	-2.66	0.74	-145.05
9	-5.34	0.54	-157.73	-43.78	0.01	-158.45	-50.24	3.08E-03	-139.23	-3.08	0.70	-163.37
10	-6.39	0.48	-171.67	-40.49	0.01	155.31	-50.30	3.05E-03	-160.03	-3.67	0.66	178.35
11	-7.43	0.43	174.81	-33.61	0.02	103.90	-48.81	3.63E-03	172.69	-4.28	0.61	159.54
12	-8.39	0.38	163.69	-25.85	0.05	33.83	-46.83	4.55E-03	168.52	-4.97	0.56	140.38
13	-9.21	0.35	152.72	-17.98	0.13	-24.57	-45.51	5.31E-03	133.77	-5.86	0.51	120.58
14	-9.84	0.32	141.91	-10.27	0.31	-76.24	-49.80	3.24E-03	122.01	-6.86	0.45	99.88
15	-10.21	0.31	132.89	-3.24	0.69	-126.21	-47.33	4.30E-03	120.33	-8.29	0.39	78.40
16	-10.50	0.30	119.24	3.46	1.49	-177.90	-44.28	6.11E-03	104.06	-10.14	0.31	57.19
17	-11.09	0.28	107.27	9.86	3.11	131.33	-47.78	4.09E-03	70.83	-12.68	0.23	34.14
18	-11.92	0.25	95.38	16.43	6.63	76.66	-46.82	4.56E-03	94.42	-16.14	0.16	13.43
19	-14.27	0.19	81.85	22.99	14.11	15.73	-47.00	4.47E-03	103.59	-20.66	0.09	-18.52
20	-13.89	0.20	109.87	29.48	29.77	-61.10	-46.50	4.73E-03	95.56	-22.17	0.08	-143.49
21	-9.77	0.32	78.10	30.91	35.10	-152.91	-48.99	3.55E-03	80.33	-15.57	0.17	117.96
22	-10.36	0.30	50.77	30.16	32.21	139.42	-50.84	2.87E-03	78.70	-17.93	0.13	90.58
23	-10.95	0.28	33.06	28.41	26.33	83.98	-47.76	4.09E-03	119.47	-13.25	0.22	59.11
24	-12.82	0.23	-7.39	28.94	27.98	41.41	-43.84	6.43E-03	113.60	-17.27	0.14	0.38
25	-20.01	0.10	-46.93	29.56	30.07	-9.55	-43.25	6.88E-03	101.42	-24.21	0.06	-68.05
26	-16.16	0.16	-172.38	30.49	33.45	-62.31	-37.97	1.26E-02	93.87	-13.35	0.22	177.64
27	-13.11	0.22	109.32	29.15	28.67	-116.72	-38.53	1.18E-02	73.46	-11.00	0.28	111.78
28	-12.47	0.24	57.26	27.40	23.44	-157.52	-38.07	1.25E-02	60.67	-10.32	0.30	62.98
29	-12.52	0.24	29.69	26.16	20.32	163.66	-40.03	9.96E-03	48.58	-10.89	0.29	37.37
30	-14.80	0.18	11.67	25.97	19.89	122.81	-37.42	1.35E-02	39.15	-14.08	0.20	10.50
31	-17.96	0.13	12.34	25.69	19.24	87.37	-40.96	8.96E-03	31.23	-18.34	0.12	15.03
32	-16.96	0.14	6.25	25.24	18.29	51.25	-41.53	8.38E-03	21.47	-17.26	0.14	24.80
33	-20.37	0.10	-39.68	25.57	18.98	15.77	-39.63	1.04E-02	31.00	-19.79	0.10	22.11
34	-21.47	0.08	-3.95	25.51	18.86	-19.79	-42.35	7.63E-03	29.06	-13.89	0.20	17.95
35	-22.83	0.07	58.23	25.74	19.36	-59.85	-41.35	8.56E-03	19.38	-15.72	0.16	14.36
36	-31.25	0.03	74.59	26.60	21.37	-96.11	-41.97	7.97E-03	52.10	-17.91	0.13	-22.92
37	-16.05	0.16	33.66	26.59	21.35	-132.80	-38.56	1.18E-02	48.65	-13.59	0.21	22.15
38	-16.50	0.15	-19.00	27.70	24.26	-173.30	-36.70	1.46E-02	19.68	-11.01	0.28	-23.76
39	-20.37	0.10	-58.53	28.06	25.30	143.64	-37.38	1.35E-02	11.78	-9.50	0.33	-45.77
40	-27.13	0.04	-29.10	28.27	25.92	100.93	-44.07	6.26E-03	24.64	-13.62	0.21	-88.86
41	-13.76	0.21	-139.61	30.33	32.83	52.80	-34.12	1.97E-02	35.07	-7.29	0.43	-123.86
42	-13.77	0.20	125.55	29.21	28.86	-3.22	-36.28	1.53E-02	15.02	-9.84	0.32	167.90
43	-9.12	0.35	79.00	27.77	24.47	-55.08	-35.34	1.71E-02	-13.52	-8.57	0.37	102.39
44	-9.17	0.35	36.59	26.84	21.98	-97.87	-34.73	1.83E-02	-24.73	-9.16	0.35	55.64
45	-12.24	0.24	23.69	26.90	22.13	-146.40	-41.12	8.79E-03	-26.28	-13.03	0.22	47.72
46	-16.79	0.14	-23.95	27.55	23.85	161.76	-43.52	6.67E-03	-47.41	-20.18	0.10	47.13
47	-19.26	0.11	-63.42	28.08	25.36	100.83	-45.53	5.29E-03	13.07	-15.83	0.16	-14.71
48	-18.84	0.11	-143.35	26.33	20.72	25.90	-35.90	1.60E-02	56.12	-17.39	0.14	-122.16
49	-13.89	0.20	61.11	20.46	10.54	-43.29	-44.84	5.73E-03	-23.47	-15.07	0.18	63.99
50	-12.26	0.24	44.00	14.02	5.02	-100.68	-32.47	2.38E-02	-7.26	-12.37	0.24	50.76

Note:

1. Data obtained from on-wafer measurements.

Biasing and Operation

AMMC-6345 has quite flexible drain biasing conditions. Recommended quiescent DC bias condition for optimum power and linearity performances is $V_d=5$ volts with V_g set for $I_d=480$ mA. For high gain applications, the AMMC-6345 can be biased at $V_d=3V$. Minor improvements in performance are possible depending on the application. The drain bias voltage range is 3 to 5.5V. A single DC gate supply connected to V_g will bias all gain stages. Muting can be accomplished by setting V_g to the pinch-off voltage V_p .

An optional output power detector network is also provided. The differential voltage between the Det-Ref and Det-Out pads can be correlated with the RF power emerging from the RF output port. The detected voltage is given by :

$$V = (V_{ref} - V_{det}) - V_{ofs}$$

where V_{ref} is the voltage at the $DET - R$ port, V_{det} is a voltage at the $DET - O$ port, and V_{ofs} is the zero-input-power offset voltage. There are three methods to calculate :

1. V_{ofs} can be measured before each detector measurement (by removing or switching off the power source and measuring). This method gives an error due to temperature drift of less than 0.01dB/50°C.
2. V_{ofs} can be measured at a single reference temperature. The drift error will be less than 0.25dB.
3. V_{ofs} can either be characterized over temperature and stored in a lookup table, or it can be measured at two temperatures and a linear fit used to calculate at any temperature. This method gives an error close to the method #1.

The RF ports are AC coupled at the RF input to the first stage and the RF output of the final stage. No ground wires are needed since ground connections are made with plated through-holes to the backside of the device.

Assembly Techniques

The backside of the MMIC chip is RF ground. For microstrip applications the chip should be attached directly to the ground plane (e.g. circuit carrier or heatsink) using electrically conductive epoxy^[1].

For best performance, the topside of the MMIC should be brought up to the same height as the circuit surrounding it. This can be accomplished by mounting a gold plate metal shim (same length and width as the MMIC) under the chip which is of correct thickness to make the chip and adjacent circuit the same height. The amount of epoxy used for the chip and/or shim attachment should be just enough to provide a thin fillet around the bottom perimeter of the chip or shim. The ground plain should be free of any residue that may jeopardize electrical or mechanical attachment.

The location of the RF bond pads is shown in Figure 12. Note that all the RF input and output ports are in a Ground-Signal configuration.

RF connections should be kept as short as reasonable to minimize performance degradation due to undesirable series inductance. A single bond wire is normally sufficient for signal connections, however double bonding with 0.7 mil gold wire or use of gold mesh^[2] is recommended for best performance, especially near the high end of the frequency band.

Notes:

1. Ablebond 84-1 LM1 silver epoxy is recommended.
2. Buckbee-Mears Corporation, St. Paul, MN, 800-262-3824

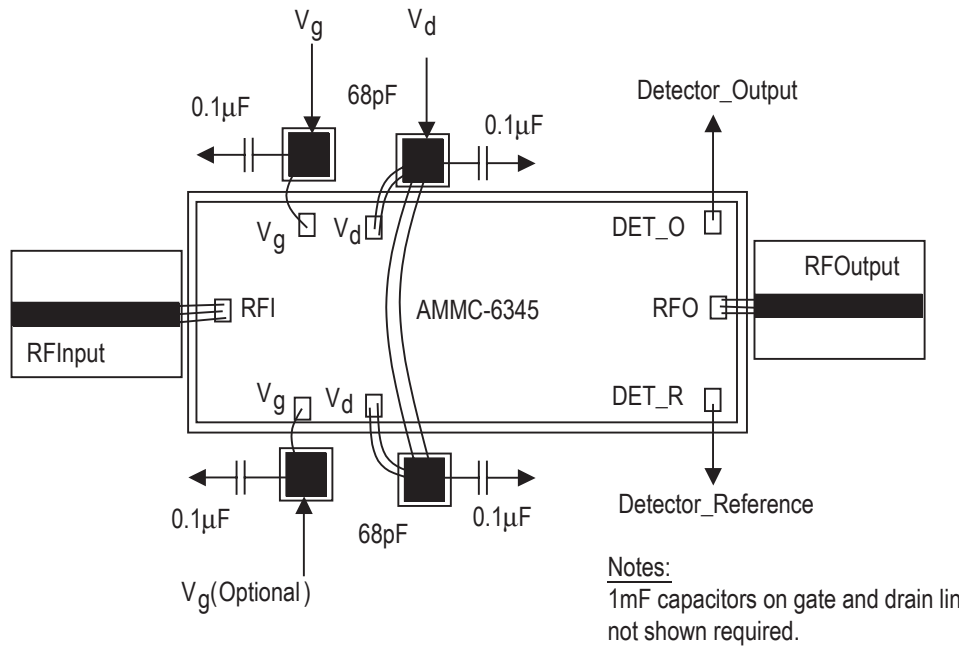

Figure 13. AMMC-6345 Assembly diagram

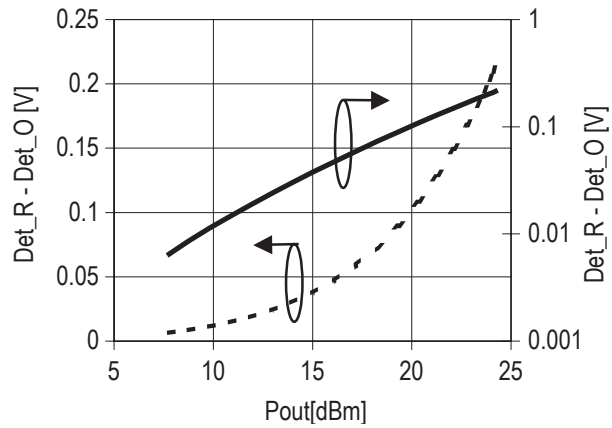

Figure 14. AMMC-6345 Typical Detector Voltage and Output Power, Freq=40 GHz

Ordering Information:

AMMC-6345-W10 = 10 devices per tray

AMMC-6345-W50 = 50 devices per tray

For product information and a complete list of distributors, please go to our web site: www.avagotech.com

Avago, Avago Technologies, and the A logo are trademarks of Avago Technologies, Limited in the United States and other countries.
Data subject to change. Copyright © 2006 Avago Technologies Limited. All rights reserved. Obsoletes 5989-4329EN
AV02-0048EN - December 20, 2006

