

Am25LS2520

Octal D-Type Flip-Flop with Clear, Clock Enable and Three-State Control

Am25LS2520

DISTINCTIVE CHARACTERISTICS

- Buffered common clock enable input
- Buffered common asynchronous clear input
- Three-state outputs
- 8-bit, high-speed parallel register with positive edge-triggered, D-type flip-flops
- Am25LS Family offers improved sink current, source current and noise margin

GENERAL DESCRIPTION

The Am25LS2520 is an 8-bit register built using advanced Low-Power Schottky technology. The register consists of eight D-type flip-flops with a buffered common clock, a buffered common clock enable, a buffered asynchronous clear input, and three-state outputs.

When the clear input is LOW, the internal flip-flops of the register are reset to logic 0 (LOW), independent of all other inputs. When the clear input is HIGH, the register operates in the normal fashion.

When the three-state output enable (\overline{OE}) input is LOW, the Y outputs are enabled and appear as normal TTL outputs.

When the output enable (\overline{OE}) input is HIGH, the Y outputs are in the high impedance (three-state) condition. This does not affect the internal state of the flip-flop Q output.

The clock enable input (\overline{E}) is used to selectively load data into the register. When the \overline{E} input is HIGH, the register will retain its current data. When the \overline{E} is LOW, new data is entered into the register on the LOW-to-HIGH transition of the clock input.

This device is packaged in a space-saving (0.4-inch row spacing) 22-pin package and in a 24-pin flatpack.

BLOCK DIAGRAM

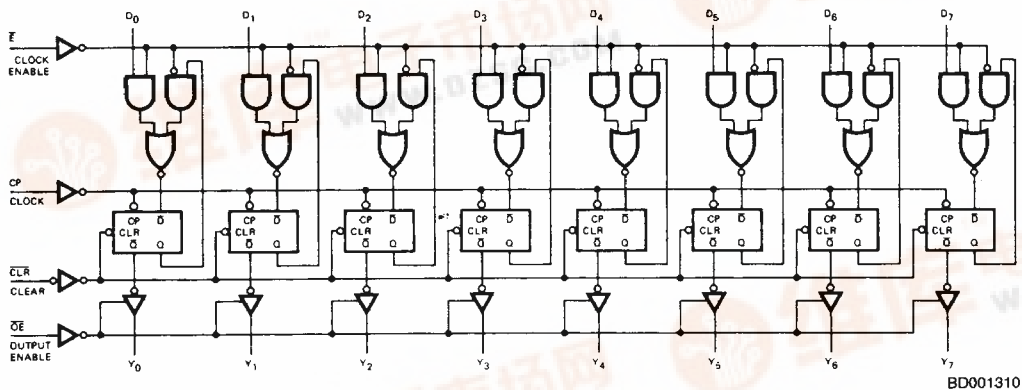

RELATED PRODUCTS

Part No.	Description
Am25S18	Quad D Register
Am2920	Octal D-Type Flip-flop
Am2954/5	Octal D Registers



**CONNECTION DIAGRAM
Top View**

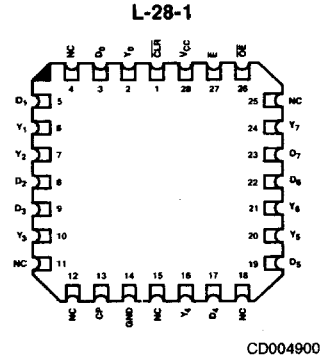
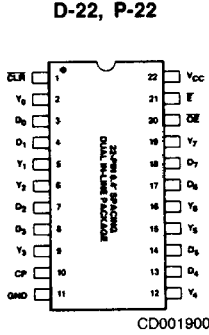
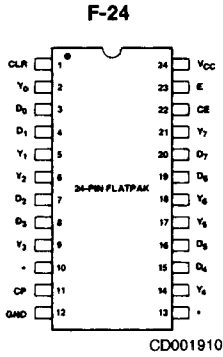

Note: Pin 1 is marked for orientation
*Reserved - do not use.

LOGIC SYMBOL

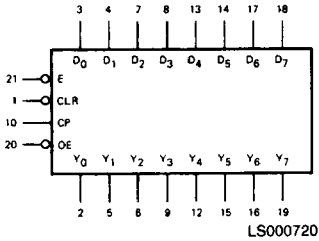

METALLIZATION AND PAD LAYOUT

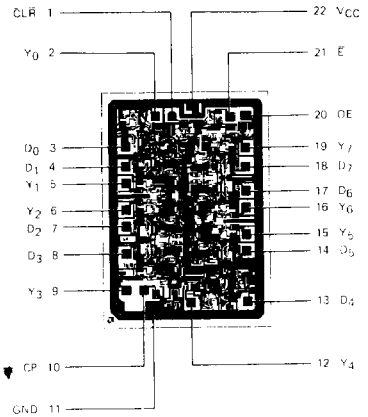

ORDERING INFORMATION

AMD products are available in several packages and operating ranges. The order number is formed by a combination of the following: Device number, speed option (if applicable), package type, operating range and screening option (if desired).

Am25LS2520

D

C

B

Screening Option
Blank - Standard processing
B - Burn-in

Temperature (See Operating Range)
C - Commercial (0°C to +70°C)
M - Military (-55°C to +125°C)

Package
D - 22-pin CERDIP
F - 24-pin flatpak
L - 28-pin leadless chip carrier
P - 22-pin plastic DIP
X - Dice

Device type
Octal D-type Flip-Flop

Valid Combinations

Am25LS2520	PC
	DC, DM
	FM
	LC, LM
	XC, XM

Valid Combinations

Consult the AMD sales office in your area to determine if a device is currently available in the combination you wish.

PIN DESCRIPTION

Pin No.	Name	I/O	Description
	D _i	I	The D flip-flop data inputs.
1	CLR	I	When the clear input is LOW, the Q _i outputs are LOW, regardless of the other inputs. When the clear input is HIGH, data can be entered into the register.
11	CP	I	Clock Pulse for the Register; enters data into the register on the LOW-to-HIGH transition.
	Y _i	O	The register three-state outputs.
21	E	I	Clock Enable. When the clock enable is LOW, data on the D _i input is transferred to the Q _i output on the LOW-to-HIGH clock transition. When the clock enable is HIGH, the Q _i outputs do not change state, regardless of the data or clock input transitions.
20	OE	I	Output Control. When the OE input is HIGH, the Y _i outputs are in the high impedance state. When the OE _i input is LOW, the TRUE register data is present at the Y _i outputs.

FUNCTION TABLE

Function	Inputs					Internal	Outputs
	OE	CLR	E	D _i	CP	Q _i	Y _i
Hi-Z	H	X	X	X	X	X	Z
Clear	H	L	X	X	X	L	Z
	L	L	X	X	X	L	L
Hold	H	H	H	X	X	NC	Z
	L	H	H	X	X	NC	NC
Load	H	H	L	L	↑	L	Z
	H	H	L	H	↑	H	Z
	L	H	L	L	↑	L	L
	L	H	L	H	↑	H	H

H = HIGH
 L = LOW
 NC = No change
 ↑ = LOW-to-HIGH Transition
 X = Don't Care
 Z = High-Impedance

APPLICATIONS

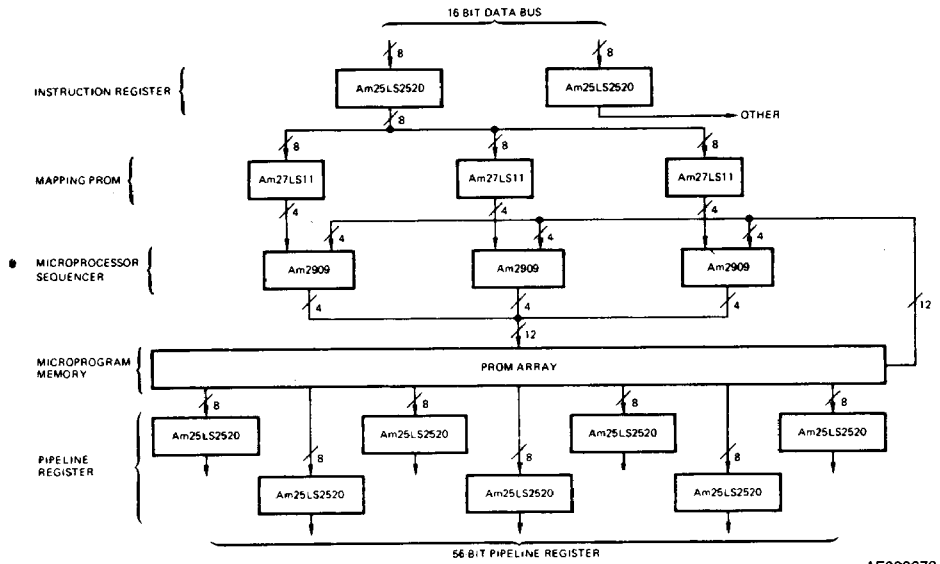

A typical Computer Control Unit for a microprogrammed machine.

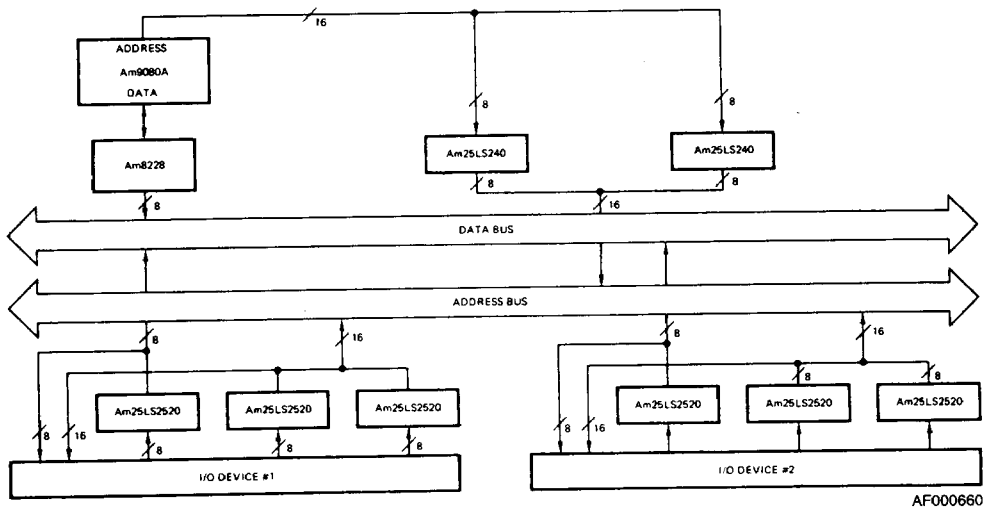

The Am25LS2520 is a useful device in interfacing with the Am9080A system buses.

ABSOLUTE MAXIMUM RATINGS

Storage Temperature	-65°C to +150°C
(Ambient) Temperature Under Bias	-55°C to +125°C
Supply Voltage to Ground Potential	
Continuous	-0.5V to +7.0V
DC Voltage Applied to Outputs For	
High Output State	-0.5V to +V _{CC} max
DC Input Voltage	-0.5V to +7.0V
DC Output Current, Into Outputs	30mA
DC Input Current	-30mA to +5.0mA

Stresses above those listed under ABSOLUTE MAXIMUM RATINGS may cause permanent device failure. Functionality at or above these limits is not implied. Exposure to absolute maximum ratings for extended periods may affect device reliability.

OPERATING RANGES

Commercial (C) Devices

Temperature	0°C to +70°C
Supply Voltage	+4.75V to +5.25V

Military (M) Devices

Temperature	-55°C to +125°C
Supply Voltage	+4.5V to +5.5V

Operating ranges define those limits over which the functionality of the device is guaranteed.

DC CHARACTERISTICS over operating range unless otherwise specified

Parameters	Description	Test Conditions (Note 2)		Min	Typ (Note 1)	Max	Units
V _{OH}	Output HIGH Voltage	V _{CC} = MIN V _{IN} = V _{IH} or V _{IL}	MIL, I _{OH} = -1.0mA	2.4	3.4		Volts
			COM'L, I _{OH} = -2.6mA	2.4	3.4		
V _{OL}	Output LOW Voltage	V _{CC} = MIN V _{IN} = V _{IH} or V _{IL}	I _{OL} = 4.0 mA			0.4	Volts
			I _{OL} = 8.0mA			0.45	
V _{IH}	Input HIGH Level	Guaranteed input logical HIGH voltage for all inputs		2.0			Volts
V _{IL}	Input LOW Level	Guaranteed input logical LOW voltage for all inputs.		MIL		0.7	Volts
				COM'L		0.8	
V _I	Input Clamp Voltage	V _{CC} = MIN, I _{IN} = -18mA				-1.5	Volts
I _{IL}	Input LOW Current	V _{CC} = MAX, V _{IN} = 0.4V				-0.36	mA
I _{IH}	Input HIGH Current	V _{CC} = MAX, V _{IN} = 2.7V				20	μA
I _I	Input HIGH Current	V _{CC} = MAX, V _{IN} = 7.0V				0.1	mA
I _O	Off-State (High-Impedance) Output Current	V _{CC} = MAX		V _O = 0.4V		-20	μA
				V _O = 2.4V		20	
I _{SC}	Output Short Circuit Current (Note 3)	V _{CC} = MAX		-15		-85	mA
I _{CC}	Power Supply Current (Note 4)	V _{CC} = MAX			24	37	mA

Notes: 1. Typical limits are at V_{CC} = 5.0V, 25°C ambient and maximum loading.

- For conditions shown as MIN or MAX, use the appropriate value specified under Operating Ranges for the applicable device type.
- Not more than one output should be shorted at a time. Duration of the short circuit test should not exceed one second.
- All outputs open, \bar{E} = GND, Di inputs = CLR = \bar{OE} = 4.5V. Apply momentary ground, then 4.5V to clock input.

SWITCHING CHARACTERISTICS ($T_A = +25^\circ\text{C}$, $V_{CC} = 5.0\text{V}$)

Parameters	Description	Test Conditions	Min	Typ	Max	Units	
t_{PLH}	Clock to Y_i (\overline{OE} LOW)	$C_L = 15\text{pF}$ $R_L = 2.0\text{k}\Omega$		18	27	ns	
t_{PHL}				24	36		
t_{PHL}	Clear to Y			22	35	ns	
t_s	Data (D_i)			10	3	ns	
t_h	Data (D_i)			10	3	ns	
t_s	Enable (\overline{E})		Active	15	10	ns	
			Inactive	20	12		
t_h	Enable (\overline{E})			0	0	ns	
t_s	Clear Recovery (In-Active) to Clock			11	7	ns	
t_w	Clock		HIGH	20	14	ns	
			LOW	25	13		
t_{pw}	Clear			20	13	ns	
t_{ZH}	\overline{OE} to Y_i				9	13	ns
t_{ZL}					14	21	
t_{HZ}	\overline{OE} to Y_i	$C_L = 5.0\text{pF}$ $R_L = 2.0\text{k}\Omega$		20	30	ns	
t_{LZ}				24	36		
f_{max}	Maximum Clock Frequency (Note 1)			40		MHz	

Note 1. Per industry convention, f_{max} is the worst case value of the maximum device operating frequency with no constraints on t_r , t_f , pulse width or duty cycle.

SWITCHING CHARACTERISTICS over operating range unless otherwise specified*

Parameters	Description	Test Conditions	COMMERCIAL		MILITARY		Units	
			Am25LS2520		Am25LS2520			
			Min	Max	Min	Max		
t_{PLH}	Clock to Y_i (\overline{OE} LOW)	$C_L = 50\text{pF}$ $R_L = 2.0\text{k}\Omega$		33		39	ns	
t_{PHL}				45		54		
t_{PHL}	Clear to Y			43		51	ns	
t_s	Data (D_i)		12		15		ns	
t_h	Data (D_i)		12		15		ns	
t_s	Enable (\overline{E})		Active	17		20		ns
			Inactive	20		23		
t_h	Enable (\overline{E})		0		0		ns	
t_s	Clear Recovery (In-Active) to Clock		13		15		ns	
t_{pw}	Clock		HIGH	25		30		ns
			LOW	30		35		
t_{pw}	Clear		22		25		ns	
t_{ZH}	\overline{OE} to Y_i				19		25	ns
t_{ZL}					30		39	
t_{HZ}	\overline{OE} to Y_i	$C_L = 5.0\text{pF}$ $R_L = 2.0\text{k}\Omega$		35		40	ns	
t_{LZ}				39		42		
f_{max}	Maximum Clock Frequency (Note 1)		25		20		MHz	

*AC performance over the operating temperature range is guaranteed by testing defined in Group A, Subgroup 9.

Am25LS2520 LOW-POWER SCHOTTKY INPUT/OUTPUT CURRENT INTERFACE CONDITIONS

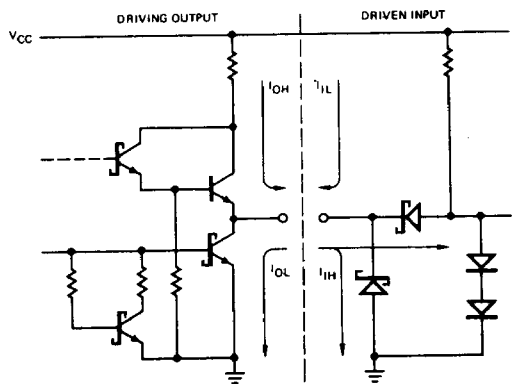

Note: Actual current flow direction shown.