

IC FOR PROXIMITY DETECTOR

AM 313

GENERAL DESCRIPTION

The AM 313 is a bipolar monolithic Integrated Circuit designed for proximity detection applications. The function is based on the damping of an LC oscillator which switches a transistor and LED output.

FEATURES

- Wide Supply Voltage Range from 4.75 to 35V
- Supply Current Without Oscillator typical 1mA
- Complementary Outputs with Short-Circuit Protection
- P-Type Drivers for PNP Bipolar and PMOS Transistors
- Adjustable Output Current From 100 μ A to 12mA
- Adjustable Detection Distance and Hysteresis
- Adjustable Temperature Compensation for Detection Distance
- Protection against False Polarity
- Power-On-Delay
- LED Output 4mA typical

BLOCK DIAGRAM

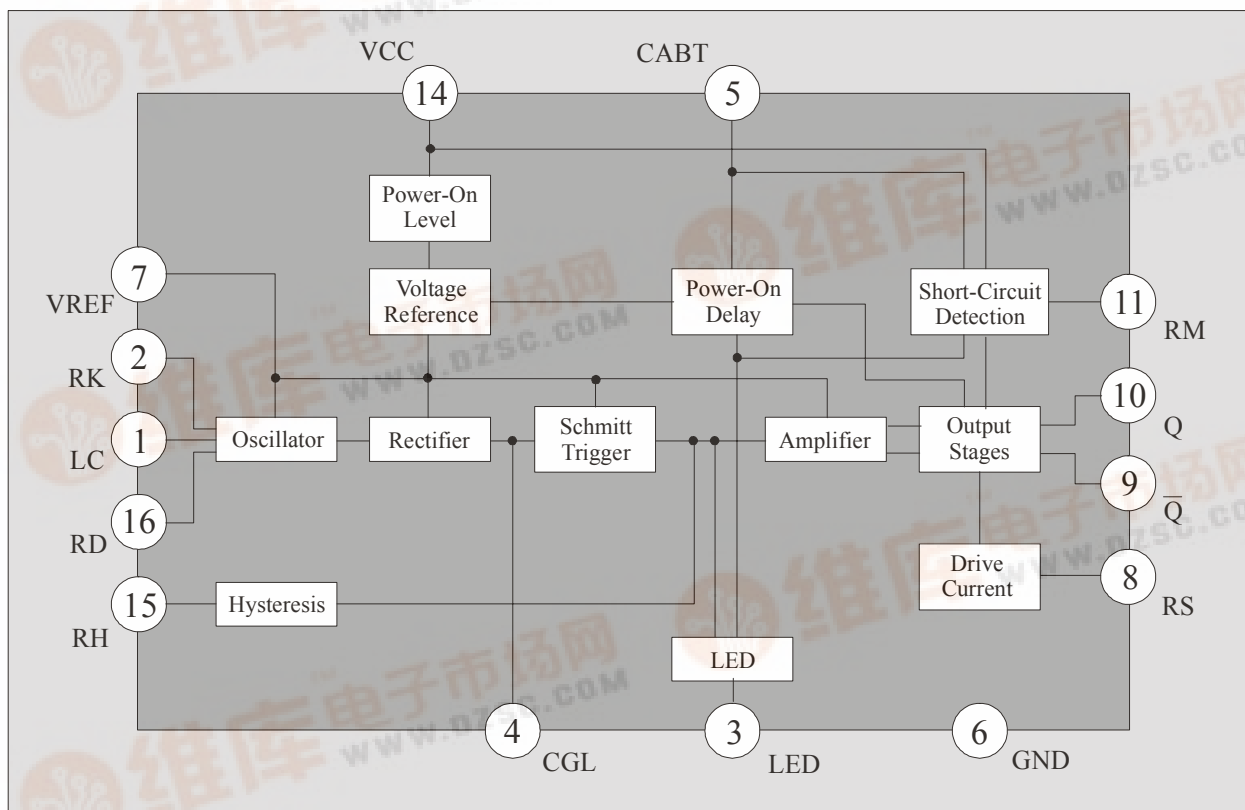

Figure 1

ELECTRICAL SPECIFICATIONS

$T_{amb} = 25^{\circ}\text{C}$, $V_{CC} = 4.75$ to 35 V

Parameter	Symbol	Conditions	Min.	Typ.	Max.	Unit
Supply Current	I_{CC}	$V_{CC} = 4.75\text{V}$, $I_{Rd} = 0\mu\text{A}$	0.6	0.9	1.2	mA
		$V_{CC} = 4.75\text{V}$, $I_{Rd} = 220\mu\text{A}$	1.2	1.5	1.8	mA
		$V_{CC} = 35\text{V}$, $I_{Rd} = 0\mu\text{A}$	0.8	1.1	1.5	mA
Output Source Current	I_{QL} (res. I_Q)	$V_{Cabl} = 2\text{V}$, $V_{CC} = 35\text{V}$	100	150	200	μA
Output Sink Current	I_{QL}	without external R_S	100	150	200	μA
Max. Current	$I_{QL} = f(R_S)$	$R_S = 5\Omega$	12	18		mA
Low Output Voltage	U_{QL}	$I_{ext} = 100\mu\text{A}$	0.6	0.9	1.2	V
High Output Voltage	U_Q (res. U_Q)	$V_{Cgl} = 2\text{V}$, $V_{CC} = 4.75\text{V}$	4.45		4.75	V
LED Output Current	I_{LED}		2.8	4		mA
Short Circuit Detection Threshold	U_m		250	300	350	mV
Current Short Circuits	I_{ON}	$V_{Cabl} = 2\text{V}$, $V_{Rm} = 1\text{V}$	50	80	150	μA
	I_{OFF}	$V_{Cabl} = 1\text{V}$, $V_{Rm} = 1\text{V}$	-1.7	-1.2	-0.7	μA

TYPICAL PERFORMANCE CHARACTERISTICS

$V_{CC} = 5\text{V}$

Parameter	Symbol	Conditions	Min.	Typ.	Max.	Unit	
Scanning Duty Cycle (in Short Circuit Mode)	T_{ON}	$C_{abt} = 0\text{nF}$, $U_m = 1\text{V}$		4		μs	
		$C_{abt} = 1\text{nF}$, $U_m = 1\text{V}$		21		μs	
	T_{OFF}	$C_{abt} = 0\text{nF}$, $U_m = 1\text{V}$			350		μs
		$C_{abt} = 1\text{nF}$, $U_m = 1\text{V}$			2.0		ms
Power-On-Delay	T_{abt}	$C_{abt} = 0\text{nF}$		380		μs	
		$C_{abt} = 1\text{nF}$		2.3		ms	
Oscillator Frequency	f_{Osc}	depends on LC res.	0.05		2.6	MHz	
Oscillator Amplitude	V_{Osc}			1.2	2	Vpp	
Detection Frequency	f_{det}	($f_{Osc} = 770\text{kHz}$, $Q = 16$)		5		kHz	
Detection Distance Res.	R_d		3			k Ω	
Hysteresis Resistor	R_h	$R_h \gg R_d$		30		k Ω	
Det. Distance Temp. Comp. Res.	R_k	external	0		1.4	k Ω	
Rectifier Filter Capacitor	$C_{gl_{ext}}$	depends on f_{Osc} ($C_{gl_{int}} = 150\text{pF}$)	0	150		pF	

ABSOLUTE MAXIMUM RATINGS

Supply Voltage V_{CC}	35V
Output Voltage U_O	32V
Output Current I_{OL}	20mA
Junction Temperature T_J	150°C
Power Dissipation at $T_{amb} = 25^\circ\text{C}$	$P_D = 600\text{mW}$
Derate for $T_{amb} > 25^\circ\text{C}$	$1/R_\theta = 5\text{mW}/^\circ\text{C}$
Storage Temperature Range T_{st}	$-55\dots125^\circ\text{C}$
Operating Temperature Range T_{amb}	$-25\dots85^\circ\text{C}$ ($V_{CC} = 15\text{V to }35\text{V}$)
	$-20\dots85^\circ\text{C}$ ($V_{CC} = 4.75\text{V to }35\text{V}$)

FUNCTIONAL DESCRIPTION

The proximity detection is based on the amplitude attenuation of an LC-oscillator which depends on the distance to a metal object.

The signal from the oscillator is rectified and filtered, then detected by a Schmitt-Trigger which switches the outputs Q (for close switch operation) and \bar{Q} (for open switch operation).

An additional LED output shows the on-state of the detection. The LED is blanked in the case of short circuit. To protect the circuit from overload, the outputs are disconnected and retested periodically. The limitation of the output current is set by the resistor R_m .

The temperature compensation to adapt the oscillator voltage to different types of external LC resonators is performed by connecting a resistor between pins 7 (V_{REF}) and 2 (R_K).

The circuit has a power-on-delay which is adjusted with C_{ABT} . Within this delay, the outputs Q and \bar{Q} are set to high level.

FUNCTIONAL DIAGRAMS

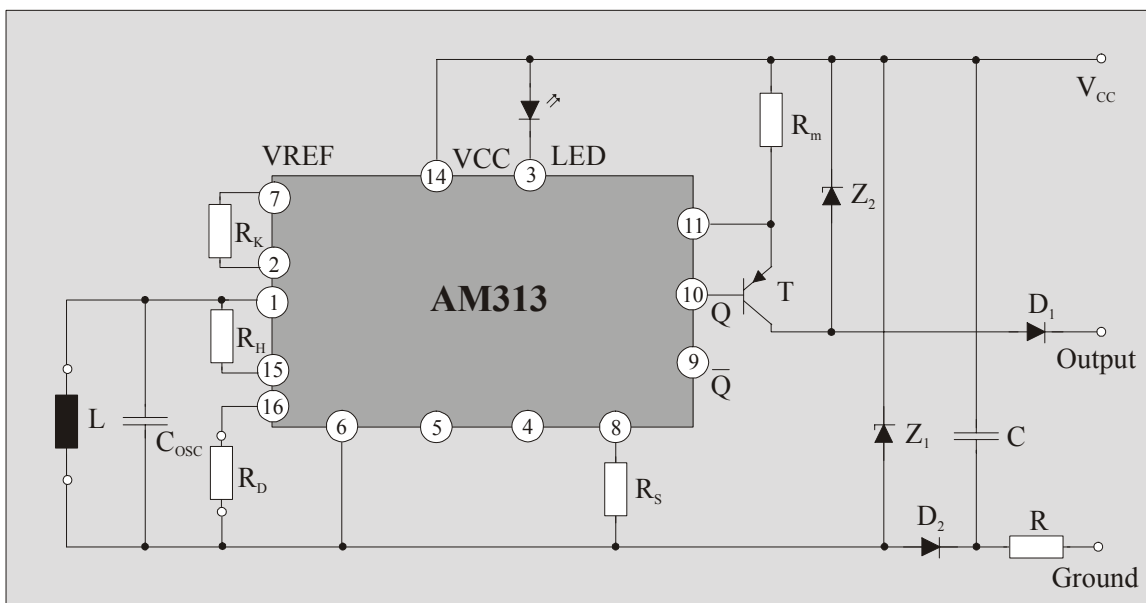

Figure 2

PINOUT

PIN	NAME	DESIGNATION
1	<i>LC</i>	Resonator Input
2	<i>RK</i>	Detection Distance Temp. Comp.
3	<i>LED</i>	LED Driver
4	<i>CGL</i>	Rectifier Filter Capacitor
5	<i>CABT</i>	Power-On-Delay Adjust Cap.
6	<i>GND</i>	Ground
7	<i>VREF</i>	Reference Voltage Output
8	<i>RS</i>	Output Transistor Current Adjust
9	\bar{Q}	Output \bar{Q} (open switch)
10	<i>Q</i>	Output <i>Q</i> (closed switch)
11	<i>RM</i>	Short Circuit Detection Input
12	<i>NC</i>	Not Connected
13	<i>NC</i>	Not Connected
14	<i>VCC</i>	Positive Supply Voltage
15	<i>RH</i>	Hysteresis Adjust
16	<i>RD</i>	Detection Distance Adjust

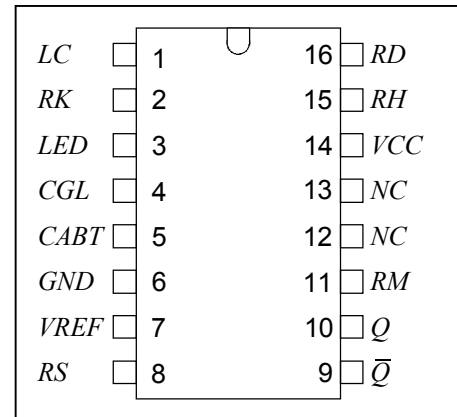

Figure 1

DELIVERY

The AM 313 is available in version:

- 16-pin-DIL packages (samples)
- SO 16 (n)-packages
- dice on 5" blue foil