

AM452 – Voltage-to-current transducer IC with a differential input

PRINCIPLE FUNCTION

Amplification and conversion of differential input voltages ($\pm 400\text{mV}$ with a CMIR of $1.5 - V_{CC} - 3\text{V}$) into an adjustable current output of $0/4 \dots 20\text{mA}$, for example. The offset and maximum output currents are independently adjustable in a wide range. The IC is suitable for both 2- and 3-wire applications and as a HART[®] carrier IC.

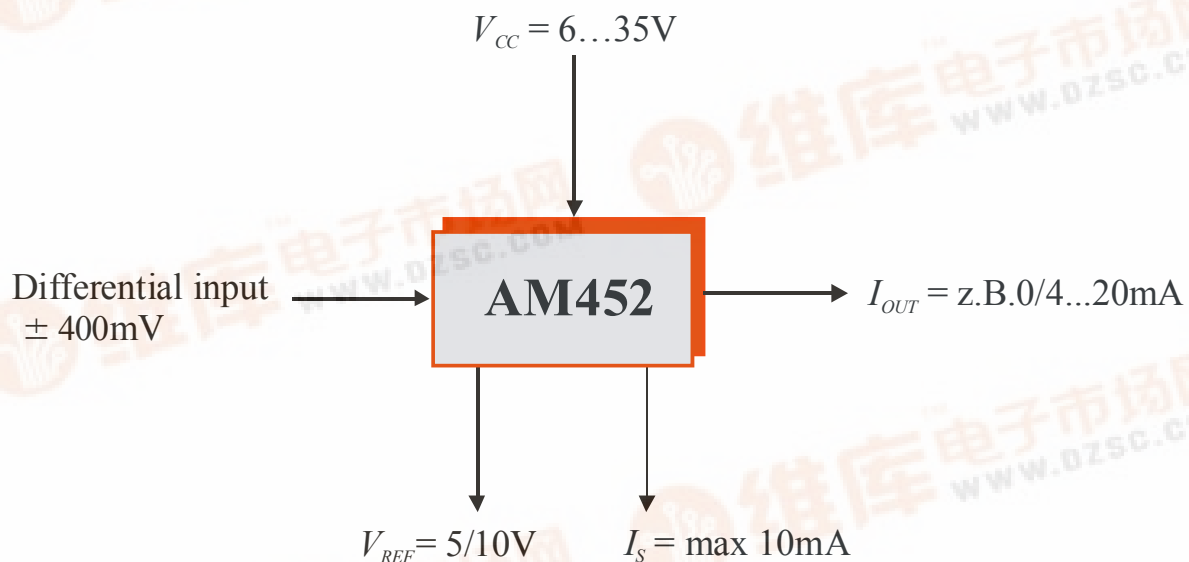

TYPICAL APPLICATIONS

Transducers for differential input signals in current output values for:

- Transducers for sensor applications with an internal sensing element supply
- Drivers for the analog industrial power grid (e.g. remote display in current loop operation)
- Differential impedance converters
- Carrier for standard HART[®] protocol communications
- Modular signal conditioning with digital correction (Frame concept [1])

AM452 – Voltage-to-current transducer IC with a differential input

TABLE OF CONTENTS

PRINCIPLE FUNCTION	1
FEATURES	3
SCHEMATIC	3
GENERAL DESCRIPTION	3
ELECTRICAL SPECIFICATIONS	4
BOUNDARY CONDITIONS	7
DETAILED DESCRIPTION OF FUNCTIONS	8
<i>Instrumentation amplifier (IA)</i>	8
<i>Operational amplifier stage (OP1)</i>	8
<i>Zero adjust stage</i>	8
<i>SET stage</i>	8
<i>Voltage-to-current converter (V/I converter)</i>	8
<i>Reference voltage source</i>	8
<i>Additional operational amplifier OP2</i>	8
OPERATING AM452	8
2- and 3-wire applications in general [2]	8
Differences in the AM452 circuitry with 2- and 3-wire applications	8
Selecting the supply voltage	8
Setting the offset and output current range for $V_{IN} = 0$	8
OPERATING AM452: IMPORTANT POINTS TO NOTE	8
DIMENSIONING	8
APPLICATIONS	8
Typical 3-wire application with a differential input signal	8
Typical 2-wire application with a differential input signal	8
Offset compensation using a voltage divider at SET stage	8
Using OP2 as a current source	8
Using OP2 as a voltage source	8
BLOCK DIAGRAM AND PINOUT	8
DELIVERY	8
PACKAGE DIMENSIONS	8
FURTHER READING	8
NOTES	8

AM452 – Voltage-to-current transducer IC with a differential input

FEATURES

- Instrumentation amplifier input with a wide voltage range of $\pm 400\text{mV}$
- Adjustable gain and offset
- Adjustable current output (e.g. of 0/4...20mA)
- 2- and 3-wire operation
- Suitable for HART[®] applications
- Protection against reverse polarity and short-circuiting
- Output signal limiting
- Integrated current source
- Adjustable integrated reference voltage source of 5 to 10V
- Modular configuration
- Supply voltage of 6...35V
- Temperature range of -40°C ... $+85^{\circ}\text{C}$
- RoHS compliant

GENERAL DESCRIPTION

AM452 is an integrated transducer with an adjustable current output which has been specifically designed for the conditioning of differential input signals. It permits the independent adjustment of the offset and full-scale current using just a few components.

The IC consists of various functional modules. In addition to the instrumentation amplifier in the signal path there is an operational amplifier which is used to set the gain. The offset can be adjusted using the Zero adjust stage and/or the SET stage module.

An additional operational amplifier can supply external components. The adjustable current output stage permits 2- and 3-wire operation by way of a simple amendment to the circuitry.

The IC is distinguished by its many protective functions which include protection against reverse polarity and short-circuiting and also an internal current limit.

SCHEMATIC

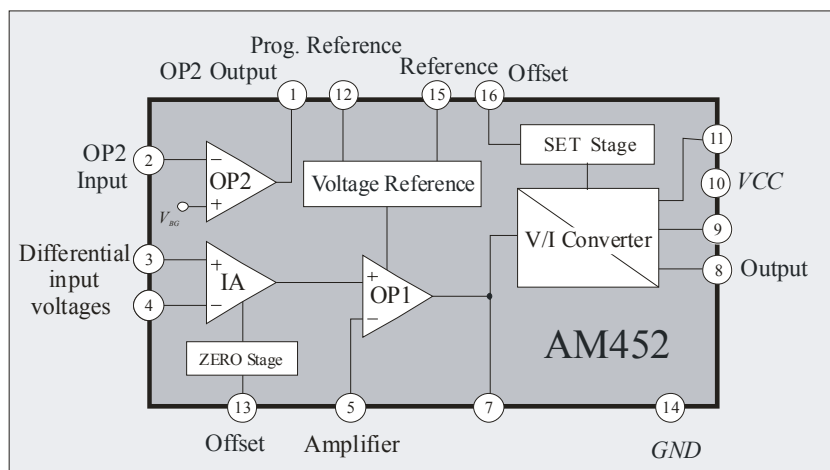

Figure 1: Schematic of AM452

AM452 – Voltage-to-current transducer IC with a differential input

ELECTRICAL SPECIFICATIONS

$T_{amb} = 25^{\circ}\text{C}$, $V_{CC} = 24\text{V}$, $V_{REF} = 5\text{V}$, $I_{REF} = 1\text{mA}$ (unless otherwise stated)

Parameter	Symbol	Conditions	Min.	Typ.	Max.	Unit
Supply Voltage Range	V_{CC}	V_{SET} not connected	6		35	V
Quiescent Current	I_{CC}	$T_{amb} = -40\dots+85^{\circ}\text{C}$, $I_{REF} = 0\text{mA}$			1.5	mA
Temperature Specifications						
Operating	T_{amb}		-40		85	$^{\circ}\text{C}$
Storage	T_{st}		-55		125	$^{\circ}\text{C}$
Junction	T_J				150	$^{\circ}\text{C}$
Voltage Reference						
Voltage	V_{REF}	V_{SET} not connected	4.75	5.00	5.25	V
	V_{REF}	$V_{SET} = GND$, $V_{CC} \geq 11\text{V}$	9.5	10.0	10.5	V
Current	I_{REF}^*		0		10.0	mA
V_{REF} vs. Temperature	dV_{REF}/dT	$T_{amb} = -40\dots+85^{\circ}\text{C}$		± 90	± 140	ppm/ $^{\circ}\text{C}$
Line Regulation	dV_{REF}/dV	$V_{CC} = 6\text{V}\dots 35\text{V}$		30	80	ppm/V
	dV_{REF}/dV	$V_{CC} = 6\text{V}\dots 35\text{V}$, $I_{REF} \approx 5\text{mA}$		60	150	ppm/V
Load Regulation	dV_{REF}/dI			0.05	0.10	%/mA
	dV_{REF}/dI	$I_{REF} \approx 5\text{mA}$		0.06	0.15	%/mA
Load Capacitance	C_L		1.9	2.2	5.0	μF
Current/Voltage Source OP2						
Internal Reference	V_{BG}		1.20	1.27	1.35	V
V_{BG} vs. Temperature	dV_{BG}/dT	$T_{amb} = -40\dots+85^{\circ}\text{C}$		± 60	± 140	ppm/ $^{\circ}\text{C}$
Current Source: $I_{CV} = V_{BG}/R_{EXT}$						
Adjustable Current Range*	I_{CV}^*		0		10	mA
Output Voltage	V_{CV}	$V_{CC} < 19\text{V}$	V_{BG}		$V_{CC} - 4$	V
	V_{CV}	$V_{CC} \geq 19\text{V}$	V_{BG}		15	V
Voltage Source: $V_{CV} = V_{BG}(R_{EXT1} + R_{EXT2}) / R_{EXT2}$						
Adjustable Voltage Range	V_{CV}	$V_{CC} < 19\text{V}$	0.4		$V_{CC} - 4$	V
	V_{CV}	$V_{CC} \geq 19\text{V}$	0.4		15	V
Output Current	I_{CV}^*	Source			10	mA
	I_{CV}	Sink			-100	μA
Load Capacitance	C_L	Source mode	0	1	10	nF

* In 2-wire operation I_S has to fulfill the condition $I_{CC} + I_S < I_{OUTmin}$ with $I_{OUTmin} = 4\text{mA}$

AM452 – Voltage-to-current transducer IC with a differential input

Parameter	Symbol	Conditions	Min.	Typ.	Max.	Unit
Instrumentation Amplifier (cont.)						
Internal Gain	G_{IA}		4.9	5	5.1	
Differential Input Voltage Range	V_{IN}		0		± 400	mV
Common Mode Input Range	$CMIR$	$V_{CC} < 9V, I_{CV} < 2mA$	1.5		$V_{CC} - 3$	V
	$CMIR$	$V_{CC} \geq 9V, I_{CV} < 2mA$	1.5		6.0	V
Common Mode Rejection Ratio	$CMRR$		80	90		dB
Power Supply Rejection Ratio	$PSRR$		80	90		dB
Offset Voltage	V_{OS}		-9.0	-1.5	+6.0	mV
V_{OS} vs. Temperature	dV_{OS}/dT			± 5		$\mu V/^{\circ}C$
Input Bias Current	I_B			-100	-250	nA
I_B vs. Temperature	dI_B/dT			-0.4	-0.9	nA/ $^{\circ}C$
Output Voltage	V_{OUTIA}	$V_{CC} < 9V$			$V_{CC} - 4$	V
	V_{OUTIA}	$V_{CC} \geq 9V$			5	V
Minimum Output Voltage	$V_{OUTIAmin}$			4.5	16	mV
Load Capacitance	C_L				250	pF
Zero Adjust Stage						
Internal Gain	G_{ZA}		0.94	1	1.06	
Zero Adjust Voltage	V_{ZA}	$V_{ZA} \leq V_{OUTIAmax} - G_{IA} \Delta V_{IN}; V_{CC} < 9V, \Delta V_{IN} = 400mV, G_{IA} = 5$	0		$V_{CC} - 6$	V
		$V_{ZA} \leq V_{OUTIAmax} - G_{IA} \Delta V_{IN}; V_{CC} \geq 9V, \Delta V_{IN} = 400mV, G_{IA} = 5$	0		3	V
Offset Voltage	V_{OS}			± 0.5	± 2.0	mV
V_{OS} vs. Temperature	dV_{OS}/dT			± 1.6	± 5	$\mu V/^{\circ}C$
Input Bias Current	I_B			47	120	nA
I_B vs. Temperature	dI_B/dT			18	30	pA/ $^{\circ}C$
Operational Amplifier – Gain Stage (OP1)						
Adjustable Gain	G_{GAIN}		1			
Input Range	IR	$V_{CC} < 10V$	0		$V_{CC} - 5$	V
		$V_{CC} \geq 10V$	0		5	V
Power Supply Rejection Ratio	$PSRR$		80	90		dB
Offset Voltage	V_{OS}		-3.0	-1.0	1.0	mV
V_{OS} vs. Temperature	dV_{OS}/dT			± 3	± 7	$\mu V/^{\circ}C$
Input Bias Current	I_B			10	25	nA
I_B vs. Temperature	dI_B/dT			7	20	pA/ $^{\circ}C$
Output Voltage Limitation	V_{LIM}			V_{REF}		V
Output Voltage Range	V_{OP}	$V_{CC} < 10V$	0		$V_{CC} - 5$	V
		$V_{CC} \geq 10V$	0		V_{REF}	V
Load Capacitance	C_L				250	pF

NB: The current in the IC is given as a negative quantity.

AM452 – Voltage-to-current transducer IC with a differential input

Parameter	Symbol	Conditions	Min.	Typ.	Max.	Unit
V/I Converter						
Internal Gain	G_{VI}		0.122	0.125	0.128	
Trim Range		Adjustable by R_0	0.60	1.00	1.40	
Voltage Range at R_0 FS	V_{R0FS}		320	540	760	mV
Offset Voltage	V_{OS}	$\beta_F \geq 100$		± 2	± 4	mV
V_{OS} vs. Temperature	dV_{OS}/dT	$\beta_F \geq 100$		± 7	± 14	$\mu V/^\circ C$
Input Resistance	R_{IN}		120	160		k Ω
R_{IN} vs. Temperature	dR_{IN}/dT		0.2	0.3		k $\Omega/^\circ C$
Output Offset Current	I_{OUTOS}	3-wire operation		-25	-35	μA
I_{OUTOS} vs. Temperature	dI_{OUTOS}/dT	3-wire operation		16	26	nA/ $^\circ C$
Output Offset Current	I_{OUTOS}	2-wire operation		9.5	14	μA
I_{OUTOS} vs. Temperature	dI_{OUTOS}/dT	2-wire operation		6	8	nA/ $^\circ C$
Output Control Current	I_{OUTC}	2-wire operation, $V_{RO}/100mV$		6	8	μA
I_{OUTC} vs. Temperature	dI_{OUTC}/dT	2-wire operation		-10	-15	nA/ $^\circ C$
Output Voltage Range	V_{OUT}	$V_{OUT} = R_L I_{OUT}, V_{CC} < 18V$	0		$V_{CC} - 6$	V
	V_{OUT}	$V_{OUT} = R_L I_{OUT}, V_{CC} \geq 18V$	0		12	V
Output Current Range FS	I_{OUTFS}	$I_{OUT} = V_{RO}/R_0$, 3-wire operation		20		mA
Output Resistance	R_{OUT}		0.5	1.0		M Ω
Load Capacitance	C_L		0		500	nF
SET Stage						
Internal Gain	G_{SET}			0.5		
Input Voltage	V_{SET}		0		1.15	V
Offset Voltage	V_{OS}		-4.0	-1.0	+2.0	mV
V_{OS} vs. Temperature	dV_{OS}/dT			± 1.6	± 5	$\mu V/^\circ C$
Input Bias Current	I_B			8	20	nA
I_B vs. Temperature	dI_B/dT			7	18	pA/ $^\circ C$
Protective Functions						
Voltage Limitation at R_0	V_{LIMR0}	$V_{R0} = V_{IN} G_I, SET = GND$		$V_{REF}/8$		mV
	V_{LIMR0}	$V_{IN} = 0, V_{R0} = V_{SET}/2$	580	635	690	mV
Protection against reverse polarity		Ground vs. V_S vs. V_{OUT}			35	V
		Ground vs. V_S vs. I_{OUT}			35	V
Current in event of reverse polarity		Ground = 35V, $V_S = I_{OUT} = 0$		4.5		mA
System Parameters						
Nonlinearity		Ideal input		0.05	0.15	%FS
3-dB-frequency	f_{3db}	$R_L = 600\Omega, C_2 = 1nF$			5	kHz
Statistical output impedance	$R_{stat.}$	$R_L = 600\Omega, C_2 = 1nF,$			$4 \cdot 10^3$	M Ω
Dynamical output impedance	$R_{dyn.}$	For $f = 2,2kHz, R_L = 600\Omega,$ $C_2 = 1nF,$			$3 \cdot 10^3$	Ω

Table 1: Specifications

AM452 – Voltage-to-current transducer IC with a differential input

BOUNDARY CONDITIONS

Parameter	Symbol	Conditions	Min.	Typ.	Max.	Unit
Sense Resistor	R_0	$I_{OUTFS} = 20\text{mA}$	16	27	38	Ω
	R_0	$c = 20\text{mA}/I_{OUTFS}$	$c \cdot 16$	$c \cdot 27$	$c \cdot 38$	Ω
Stabilization Resistor	R_5	$I_{OUTFS} = 20\text{mA}$	35	40	45	Ω
	R_5	$c = 20\text{mA}/I_{OUTFS}$	$c \cdot 35$	$c \cdot 40$	$c \cdot 45$	Ω
Load Resistance	R_L	Only for 3-wire operation	0		600	Ω
Sum Gain Resistors	$R_1 + R_2$		20		200	$\text{k}\Omega$
Sum Offset Resistors	$R_3 + R_4$		20		200	$\text{k}\Omega$
Sum IA Offset Resistor	$R_6 + R_7$		20		200	$\text{k}\Omega$
V_{REF} Capacitance	C_1	Min. value for $T_{amb} 85^\circ\text{C}$	1.9	2.2	5.0	μF
Output Capacitance	C_2	Only for 2-wire operation	90	100	250	nF
D_1 Breakdown Voltage	V_{BR}		35	50		V
T_1 Forward Current Gain	β_F	e.g. BCX54/55/56	50	150		

Table 2: Boundary conditions

NB: In 2-wire operation and with the connected resistors capacitance C_2 acts as a low pass filter with a time constant of $\tau = R_L C_2$.

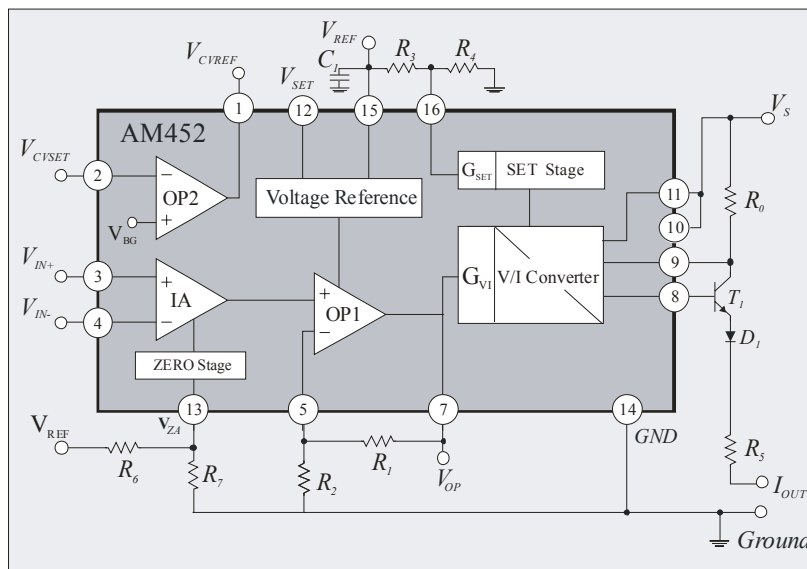

Figure 2 shows AM452 as a 3-wire application where output current $I_{OUT \min} > 0\text{mA}$ is set using the instrumentation amplifier (with a negative offset at the IA input) and the SET stage. The gain on the maximum output current is adjusted using OP1.

Figure 2: Block diagram of AM452 (3-wire version).

AM452 – Voltage-to-current transducer IC with a differential input

DETAILED DESCRIPTION OF FUNCTIONS

AM452 is a modular, monolithically integrated transducer which has been specially developed for the conditioning of differential voltage signals. It consists of several function blocks, the values of which are described in detail in the electrical specifications. Its various function blocks are depicted in the block diagram (*Figure 2*) and described in the following.

Instrumentation amplifier (IA)

The instrumentation amplifier (IA) with an internal fixed gain of $G_{IA} = 5$ acts as an input stage for differential voltage signals of $\pm 400\text{mV}$ maximum. Thanks to the device's special construction a high input impedance and high common mode rejection ratio (CMRR) are achieved. The reference potential of the amplifier can be set externally using pin 13 or Z_A , with which the offset current at the output (e.g. 4mA) can be increased. It is thus possible to compensate for the negative offset of the signal source (up to -400mV) or to correct that of the instrumentation amplifier.

The following applies to the transfer function of the instrumentation amplifier:

$$V_{OUTIA} = G_{IA} V_{IN} + V_{ZA} \quad \text{with } V_{OUTIA} > 0 \quad (1)$$

where V_{IN} describes the differential voltage between the two inputs V_{IN+} and V_{IN-} and V_{ZA} the voltage at pin 13 (Z_A) of instrumentation amplifier IA.

Operational amplifier stage (OP1)

The operational amplifier stage (OP1) permits variable amplification of the IA output signal. OP1 gain G_{GAIN} can be set via external resistors R_1 and R_2 (see *Figure 2*). Protective circuitry against overvoltage is integrated into the chip, limiting the voltage to the set value of the reference voltage. The output voltage at OP1 can be tapped for control purposes at pin 7 (VOP). This is calculated as:

$$V_{OP} = V_{OUTIA} \cdot G_{GAIN} \quad \text{with } G_{GAIN} = \left(\frac{R_1}{R_2} + 1 \right) \quad (2)$$

where V_{OUTIA} is not externally accessible but is connected internally to the OP1 input.

Zero adjust stage

The zero adjust stage enables a negative signal to be raised to a maximum of -400mV at the instrumentation amplifier input by adding an additional voltage of V_{ZA} . A zero setting which is practically offset free with regard to the following circuit modules can thus be achieved, for example. The following applies:

$$V_{ZA} \leq V_{OUTIA\text{max}} - G_{IA} \Delta V_{IN}$$

AM452 – Voltage-to-current transducer IC with a differential input

SET stage

The SET stage permits the adjustment of the offset output current $I_{OUTmin} > 0mA$. Together with the V/I converter it effects the output current I_{OUT} . Via pin 16 (*SET*) an offset current I_{SET} can be set at pin 8 (*IOUT*) e.g. with the help of the internal voltage reference and an external voltage divider as shown in *Figure 2*, for example.

Voltage-to-current converter (V/I converter)

The voltage-to-current converter (V/I converter) compares the voltage drop across the external sensing resistor R_0 with a value of $V_{SET} G_{SET} + V_{OP} G_{VI}$ and uses the result to regulate transistor T_1 . It generates a suitable signal at the IC output pin 8 (*IOUT*) which activates external transistor T_1 . This in turn supplies an output current of I_{OUT} and accepts the power dissipation of the output stage.

External resistor R_0 permits the output current to be finely adjusted. For the output current I_{OUT} amplified by T_1 the following ratio applies:

$$I_{OUT} = \frac{V_{OP} \cdot G_{VI}}{R_0} + I_{SET} = \frac{V_{OP}}{8R_0} + I_{SET} \text{ with } I_{SET} = \frac{V_{SET} \cdot G_{SET}}{R_0} = \frac{V_{SET}}{2R_0} \quad (3)/(4)$$

where V_{OP} is the input voltage of the V/I converter and V_{SET} the voltage at pin 16 (*SET*).

Reference voltage source

The reference voltage source (bandgap voltage source) enables voltage to be supplied to external components (such as sensors, microprocessors, etc.). The reference voltage value V_{REF} can be set using pin 12 (*VSET*). If pin 12 is not connected, $V_{REF} = 5V$; if pin 12 is switched to ground, $V_{REF} = 10V$. Values between these can be set if two external resistors are used (inserted between pin 15 (*VREF*) and pin 12 (*VSET*) and between pin 12 (*VSET*) and *GND*).

External capacitor C_1 stabilizes the reference voltage. It **must** be connected even if the voltage reference is not in use. It may not undershoot the given minimum value.

Additional operational amplifier OP2

The additional operational amplifier OP2 can be used as a current or voltage source to supply external components. OP2's positive input must be connected internally to bandgap voltage V_{BG} so that the OP2 output voltage at pin 1 or *CVREF* can be set across a wide range using external resistors.

The individual modules are described separately in the specifications. The reference voltage source and the operational amplifier OP2 can be operated as independent circuit elements or modules. Instrumentation amplifier IA, operational amplifier OP1 and the V/I converter form a unit within the circuit and have the task of converting the voltage input signal into the required output current.

AM452 – Voltage-to-current transducer IC with a differential input

OPERATING AM452

2- and 3-wire applications in general [2]

As AM452 can function in both 2- and 3-wire operation through external contacting, it is important to first differentiate between the two versions of the circuit.

In 2-wire operation the IC ground is "virtual" (floating), as with a constant load resistance the IC supply voltage V_{CC} changes according to the current. The following equation can generally be applied to 2-wire operation:

$$V_{CC} = V_S - I_{OUT}(V_{IN}) R_L \quad (5)$$

The reason for this is that in 2-wire operation the IC is connected in series to the actual load resistor R_L . This is illustrated in *Figure 3*.

In a 2-wire system the power consumption of the overall system (AM452 plus all external components including the signal source and adjusting resistors) may not be more than I_{OUTmin} (e.g. 4mA).

In 3-wire operation Equation (5) no longer applies as the IC ground is connected to the ground of the system. In 3-wire operation the supply voltage can be expressed as:

$$V_{CC} = V_S \quad (6)$$

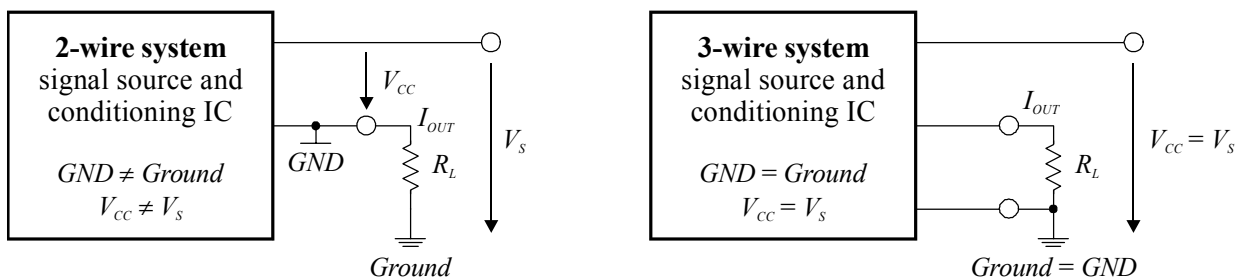

Figure 3: The basic difference between a 2- and 3-wire circuit

NB: The difference between GND and Ground must be clearly acknowledged!

AM452 – Voltage-to-current transducer IC with a differential input

Differences in the AM452 circuitry with 2- and 3-wire applications

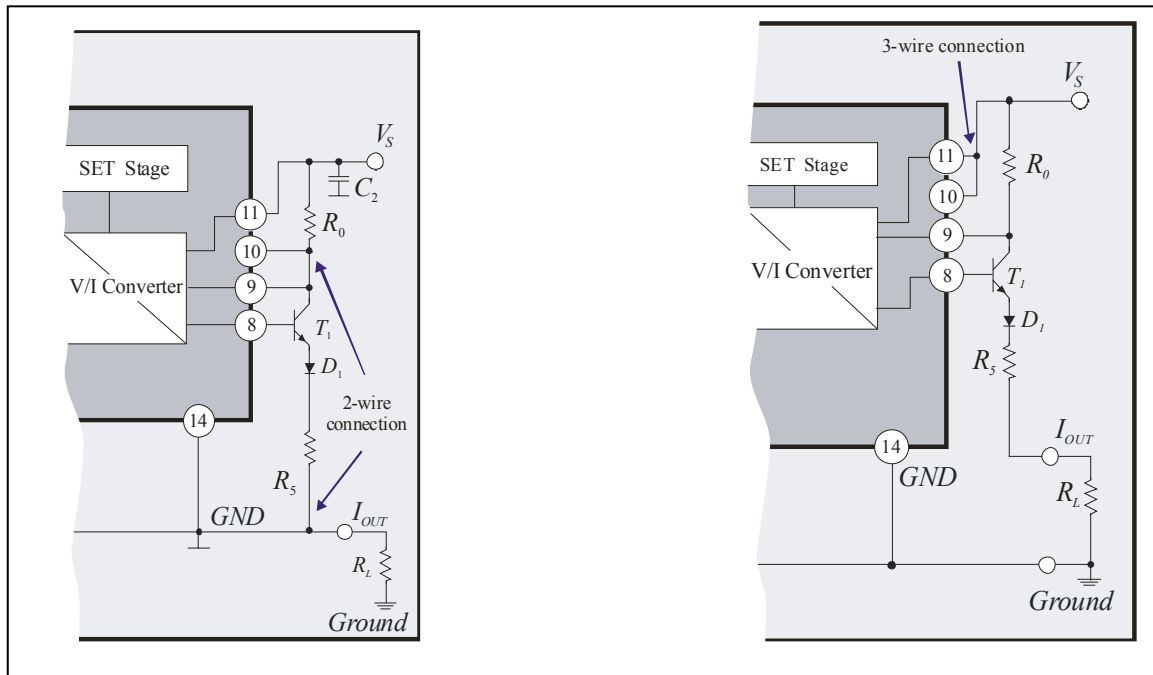

Figure 4: Differences in 2- and 3-wire circuitry in conjunction with AM452

AM452 is constructed in such a way that by changing the external circuitry it is suitable for both 2-wire and 3-wire operation.

In 3-wire operation (see *Figure 4*, right) the IC's connection to ground (pin 14 or *GND*) is connected to the system ground (*Ground*) which is applied externally. System supply voltage V_S is connected to pin 10 (*VCC*) and pin *VCC* to pin 11 (*RS+*). Supply current I_{CC} then flows directly into AM452 (power consumption).

In 2-wire operation (see *Figure 4*, left) system supply voltage V_S is connected to pin 11 (*RS+*) and pin 10 (*VCC*) to pin 9 (*RS-*). The overall current including the supply current then flows via R_0 , enabling the relevant voltage drop to be used to regulate transistor T_1 .

The IC's connection to ground pin 14 (*GND*) is connected to the node between resistor R_5 and load resistor R_L (current output I_{OUT}). IC ground *GND* is thus **not** the same as the ground of the system (*Ground*). The output signal is tapped via load resistor R_L which links system output I_{OUT} to the ground of the system.

AM452 – Voltage-to-current transducer IC with a differential input

Selecting the supply voltage

"System" supply voltage V_S needed to operate AM452 is dependent on the selected mode of operation. The word "system" here refers to the IC plus its external circuitry.

When using current output pin 8 (I_{OUT}) in conjunction with the external transistor V_S is dependent on the relevant load resistor R_L used by the application. The following is then applicable to the minimum system supply voltage V_S :

$$V_S \geq I_{OUT\max} R_L + V_{CC\min} \quad (7)$$

Here, $I_{OUT\max}$ stands for the maximum output current and $V_{CC\min}$ for the minimum IC supply voltage which is dependent on the selected reference voltage:

$$V_{CC\min} \geq V_{REF} + 1V \quad (8)$$

For the 3-wire version the load resistance is limited to $R_{L\max} = 600\Omega$ due to the condition: $V_{OUT\max} = 12V @ V_{CC} \geq 18V$.

Equation 7 is also valid for the 2-wire version; here, however, the $R_{L\max} = 600\Omega$ limitation does not apply. Here, load resistor $R_{L\max} = 900\Omega$ when $V_S = 24V$.

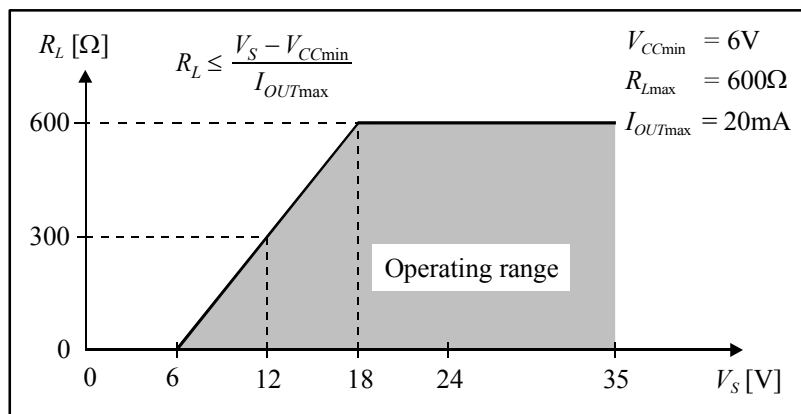

In Equation (7) of Figure 5 the ohmic resistance of power supply lines R_R is not taken into consideration. This is entered as an additive quantity ($I_{OUT\max} R_R$) to the calculation of V_S in Equation (7).

Figure 5: Working range in conjunction with the load resistor in 3-wire operation

Setting the offset and output current range for $V_{IN} = 0$

When adjusting AM452 a preset should first be made. To this end the offset of the output current is compensated for, in which the two IA inputs are first short-circuited ($V_{IN} = 0$) and then both set to a permitted potential (c.f. *CMIR* in ELECTRICAL SPECIFICATIONS). With the short-circuit at the input the following is derived from Equations (3) and (4) when the voltage divider from R_3 and R_4 is taken into account for reference voltage V_{REF} (see Figure 2, for example):

AM452 – Voltage-to-current transducer IC with a differential input

$$I_{OUT}(V_{IN} = 0) = I_{SET} \text{ with } I_{SET} = \frac{V_{REF}}{2R_0} \cdot \frac{R_4}{R_3 + R_4} \rightarrow \frac{R_3}{R_4} = \frac{V_{REF}}{2 \cdot R_0 \cdot I_{SET}} - 1 \quad (9)$$

The output current range (e.g. 16mA) is set by the selection of external resistors R_1 and R_2 (or fine adjustment with R_0). Output current I_{OUT} is then calculated as:

$$I_{OUT} = V_{IN} \frac{G_I \cdot G_{VI}}{R_0} + I_{SET} \text{ with } G_I = G_{IA} \cdot G_{GAIN} \text{ and } V_{ZA} = 0 \quad (10)$$

If the offset of the AM452 signal source and input amplifier (IA) is such that it cannot be ignored, when setting the output current range (gain) $I_{OUT}(V_{IN} = 0)$ also changes. This shift must possibly be accounted for by making a fine adjustment to R_3 and R_4 . If the offset of the signal source and input amplifier is not relevant to the required degree of precision, Equations (9) and (10) continue to apply.

OPERATING AM452: IMPORTANT POINTS TO NOTE

1. When using AM452 it is imperative that external capacitor C_1 (a ceramic capacitor) is **always** connected. Care must be taken that the value of the capacitor does not exceed the range of values given in the boundary conditions – also within the temperature range (see *Table 2*). In 2-wire operation ceramic capacitor C_2 must also be used.
2. All AM452 function blocks not required by the application (OP2 or VREF) must be placed in a defined (and allowed) operating state.
3. The voltages at the IA inputs (pins $IN+$ and $IN-$) must **always** lie within input voltage range $CMIR$.
4. At the current output a load resistance of 600Ω **maximum** is permissible for 3-wire operation.
5. The values of external resistors R_0 , R_1 , R_2 , R_3 , R_4 , R_5 , R_6 and R_7 must be selected within the permissible range given in the boundary conditions.
6. The tolerances of the resistors and their temperature coefficients are entered into the overall error.
7. In order to avoid temperature gradients it is imperative that the transistor is placed **far enough away** from IC AM452 and that a sufficient temperature outlet is ensured.
8. In a 2-wire setup with a minimum output (offset) current of $I_{OUT \min}$ the current balance (the total domestic power supply across a temperature range of $< I_{OUT \min}$) of the IC and all connected components (such as sensors) must be taken into account.

AM452 – Voltage-to-current transducer IC with a differential input

9. For applications where $I_{OUT\ min} > 0\text{mA}$ (e.g. 4mA) in both 2- and 3-wire applications the following condition applies to the IA input values:

$$\frac{V_{FS,IA}}{V_{OS,IA}} \geq \frac{I_{OUT\ max}}{I_{OUT\ min}}, \text{ where } V_{FS,IA} \text{ is the maximum input signal and } V_{OS,IA} \text{ the positive offset at the input IA.}$$

10. If signal source and/or input amplifier IA have a negative offset this can be compensated for using corrective voltage V_{ZA} and a suitable voltage divider (R_6 and R_7 ; see *Figure 2*).

DIMENSIONING

Two possible dimensioning methods are suggested here.

Dimensioning the external components according to the equations given in the data sheet

Dimensioning according to the equations given in the data sheet enables all modules to be used, making it possible for the setup to be adapted to suit the most diverse application requirements.

As a rule the offset of the AM452 input signal must be taken into account. If an input signal offset is present and an offset current of $I_{OUT\ min} > 0\text{mA}$ is required, the following boundary condition then applies:

$$\frac{V_{FS,IA}}{V_{OS,IA}} \geq \frac{I_{OUT\ max}}{I_{OUT\ min}}, \text{ where } V_{FS,IA} \text{ is the maximum input signal and}$$

$V_{OS,IA}$ the positive offset at the input IA (see: chapter before). Should the signal source have a negative offset, the offset can be set via pin 13 (ZA) and voltage divider R_6 and R_7 (see *Figure 2*). Equation (1) forms the basis for all other equations in this particular case.

If the offset is negligible, Equations (9) and (10) apply. See the following applications for further details.

Dimensioning AM452's external components using an Excel spreadsheet

AM452's external components can also be dimensioned with the help of Excel spreadsheet **Kali_AM452.xls** when the input signal is positive (see [3]). The algorithm is such that the offset output current of 4mA can only be set via pin 13 (ZA) of the zero adjust stage. The SET stage is not active. The full-scale output current is set to 20mA using the OP1 gain setting. The calibration process is also based on the condition that the output signal should be a 4...20mA current loop signal in 2-wire operation.

AM452 – Voltage-to-current transducer IC with a differential input

Due to the algorithm upon which it is based the program also accounts for the spec. tolerances of the IC and the components connected to it.

APPLICATIONS

Typical 3-wire application with a differential input signal

The aim of the calculation is the dimensioning of resistors R_0 to R_5 .

In 3-wire operation (see *Figure 6*) the IC's connection to ground (pin 14 or *GND*) is connected to the system ground (*Ground*) which is applied externally. System supply voltage V_S is connected to pin 10 or *VCC* and pin *VCC* to pin 11 or $RS+$. In this configuration AM452's quiescent current does then not flow via resistor R_0 .

Figure 6 depicts the 3-wire application in which the differential output signal of a measuring bridge supplied with current is amplified and converted. Power is supplied to the measuring bridge by operational amplifier OP2 (c.f.: *Using OP2 as a current source*).

It is assumed in this application that no negative differential input voltages occur. Pin 13 (*ZA*) is thus connected to the IC ground *GND*.

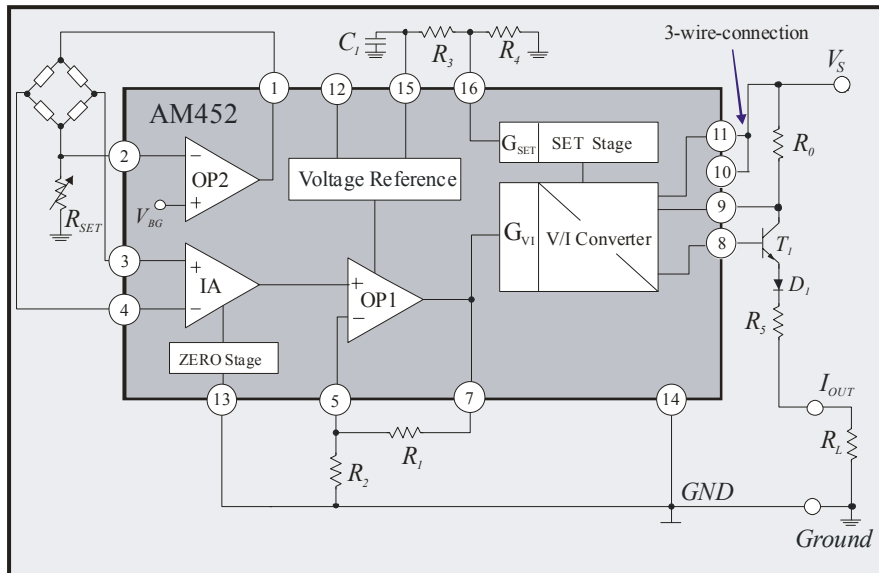

Figure 6 illustrates a typical 3-wire circuit with a positive, differential input signal which can be used for calibrated sensing elements, for example. The offset current is set using the SET stage and the full scale via the gain at OP1.

Figure 6: 3-wire application for differential input signals

According to Equations (9) and (10) the following applies to output current I_{OUT} :

$$I_{OUT} = V_{IN} \frac{G_I}{8R_0} + I_{SET} \quad \text{mit } V_{ZA} = 0 \quad (11)$$

$$\text{mit } G_I = G_{IA} \quad G_{GAIN} = 5 \left(1 + \frac{R_1}{R_2} \right) \quad \text{und} \quad I_{SET} = \frac{V_{REF}}{2R_0} \cdot \frac{R_4}{R_3 + R_4} \quad (12)$$

AM452 – Voltage-to-current transducer IC with a differential input

Here, G_1 is the overall gain of the instrumentation amplifier (IA) and the back-end operational amplifier (OP1). I_{SET} is the additional offset current which is set using a voltage at the SET pin and which can raise the output current of the VI/ converter by a constant value.

1) Example 1: $V_{IN} = 0...100\text{mV}$ differential, $I_{OUT} = 4...20\text{mA}$ (3-wire)

For a measuring bridge with a signal of $V_{IN} = 0...100\text{mV}$ (without an offset) at the IA input the external components should be dimensioned in such a way that output current I_{OUT} is $4...20\text{mA}$.

If the input signal offset is negligible, resistors R_0 , R_1 , R_2 , R_3 and R_4 must be determined. With the two voltage dividers it is sufficient to calculate just one of the two resistors; the other can be selected within the stipulations given by the boundary conditions. In this example a value of 5V has been selected for V_{REF} , with $10\text{k}\Omega$ chosen for R_2 and $5\text{k}\Omega$ for R_4 . With a current of 20mA the voltage should drop by a typical value of 540mV at resistor R_0 . The following is accrued:

$$R_0 \cdot 0.02\text{A} = 0.54\text{V} \quad (13)$$

With reference to Equations (11) and (12) and the values given in Example 1 the following is obtained:

$$0.02\text{A} = \frac{0.1\text{V} \cdot 5 \cdot \left(1 + \frac{R_1}{10\text{k}\Omega}\right)}{8 \cdot R_0} + \left(\frac{5\text{V}}{2 \cdot R_0} \cdot \frac{5\text{k}\Omega}{(R_3 + 5\text{k}\Omega)} \right)$$
$$0.004\text{A} = \frac{5\text{V}}{2 \cdot R_0} \cdot \frac{5\text{k}\Omega}{(R_3 + 5\text{k}\Omega)}$$

By solving the above system of equations and taking the given defaults into account, the following values are computed for the 3-wire, 4–20mA current interface:

$R_0 = 27\Omega$	$R_1 = 59.12\text{k}\Omega$	$R_2 = 10\text{k}\Omega$
$R_3 = 110.74\text{k}\Omega$	$R_4 = 5\text{k}\Omega$	$R_5 = 39\Omega$
$R_L = 0...600\Omega$	$C_1 = 2.2\mu\text{F}$	

If the offset output current is not exactly 4mA due to component tolerances and deviates from this value, the voltage can be adjusted at pin 16 (SET) using voltage divider R_3 and R_4 (see *Figure 7*) and the output value thus corrected (c.f.: *Offset compensation using a voltage divider at SET*).

AM452 – Voltage-to-current transducer IC with a differential input

Typical 2-wire application with a differential input signal

2) Example 2: $V_{IN} = 0...100\text{mV}$ differential, $I_{OUT} = 4...20\text{mA}$ (2-wire)

In order to determine the system resistors R_0 to R_5 must first be determined.

For a measuring bridge with a signal of $V_{IN} = 0...100\text{mV}$ (without an offset) at the IA input the external components in the AM452 circuitry should be dimensioned in such a way that the output current range is $4...20\text{mA}$. AM452 is configured in such a way that the entire current, including the chip's quiescent current, flows through R_0 (example for the 2-wire application).

As in Example 1, R_2 and R_4 can be freely selected within the boundary conditions. In this example a value of $10\text{k}\Omega$ has been chosen for R_2 , with $5\text{k}\Omega$ selected for R_4 . $V_{REF} = 5\text{V}$. The value of R_0 has been set to $33\text{k}\Omega$. Applying Equations (12) and (13) the values for R_1 and R_3 are as follows:

$$0.02\text{ A} = \frac{(0.1\text{ V} \cdot 5 \cdot (1 + \frac{R_1}{10\text{ k}\Omega}))}{8 \cdot 33\Omega} + \left(\frac{5}{2 \cdot 33\Omega} \cdot \frac{5\text{ k}\Omega}{(R_3 + 5\text{ k}\Omega)} \right)$$

$$0.004\text{ A} = \frac{5}{2 \cdot 33\Omega} \cdot \frac{5\text{ k}\Omega}{(R_3 + 5\text{ k}\Omega)}$$

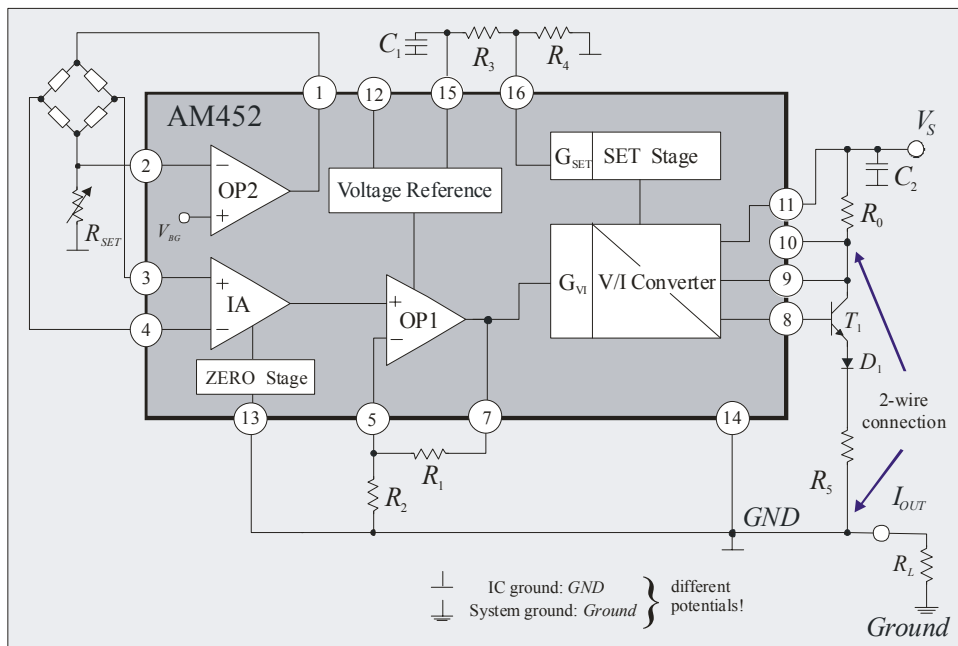

Figure 7: Typical 2-wire application for differential input signals

AM452 – Voltage-to-current transducer IC with a differential input

By solving the above system of equations and taking the given defaults for the external components into account, the following values are computed:

$$\begin{array}{lll}
 R_0 = 33\Omega & R_1 = 74.48k\Omega & R_2 = 10k\Omega \\
 R_3 = 89.7k\Omega & R_4 = 5k\Omega & R_5 = 39\Omega \\
 R_L = 0\dots900\Omega & C_1 = 2.2\mu\text{F} & C_2 = 100\text{nF}
 \end{array}$$

In the 2-wire application particular attention must be paid to the overall power consumption which may not exceed a value of 4mA across the entire temperature range.

Here it is also possible to correct the offset output current using the voltage divider at the SET stage input.

Offset compensation using a voltage divider at SET stage

The offset value of the output current can be adjusted at the SET pin (pin 16) via voltage divider R_3 and R_4 (see *Figure 7*). If, due to internal offsets and parasites, the output current is too great by 0.1mA, for example (4.1mA and 20.1mA), the current must be reduced by this amount, i.e. I_{SET} may only be 3.9mA. In this example and if $V_{REF} = 5V$ Equation (9) yields the following:

$$I_{SET} = \frac{V_{REF}}{2R_0} \cdot \frac{R_4}{R_3 + R_4} = 3,9\text{mA} = \frac{5V}{66\Omega} \cdot \frac{5k\Omega}{R_3 + 5k\Omega}$$

Once R_3 has been put through the equation $R_3 = 92.125k\Omega$ instead of 89.7k Ω . The voltage at SET (pin 16) is then just 257.4mV instead of 264mV and the output current has been reduced by 0.1mA.

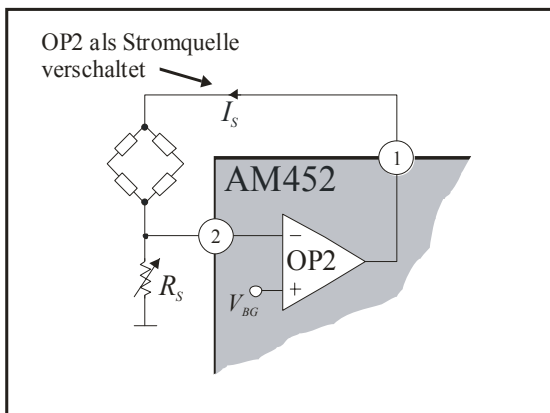

Figure 8: OP2 as a constant current source

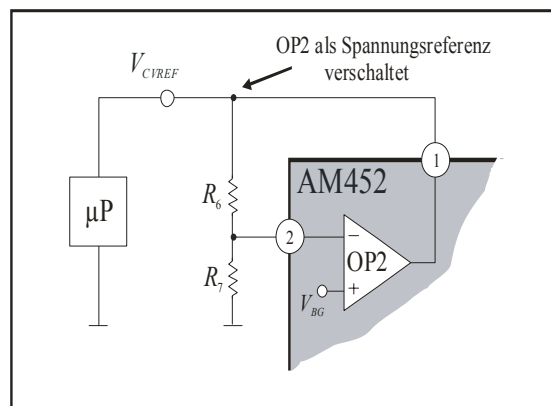

Figure 9: OP2 as a voltage reference

AM452 – Voltage-to-current transducer IC with a differential input

Using OP2 as a current source

The additional operational amplifier OP2 can easily be configured as a constant current source. Using the circuitry shown in *Figure 8* the following equation is generated:

$$I_S = \frac{V_{BG}}{R_S} = \frac{1.27\text{ V}}{R_S} \quad (14)$$

The bridge symbol is supposed to represent the component to be supplied with current (such as a piezoresistive sensing element or a temperature sensor, for example).

Example: A supply current of $I_S = 1\text{ mA}$ is to be set. Using Equation (14) the below value is accrued for external resistor R_S , which determines the quantity of current:

$$R_S = \frac{V_{BG}}{I_S} = \frac{1.27\text{ V}}{1\text{ mA}} = 1.27\text{ k}\Omega$$

Using OP2 as a voltage source

In addition to the integrated voltage reference OP2 can also be used to supply voltage to external components such as A/D converters or microprocessors, for example. This permits lower supply voltages of 3.3V, for example, to be generated. The following is derived from the circuitry in *Figure 9*:

$$V_{CVREF} = V_{BG} \left(1 + \frac{R_6}{R_7} \right) = 1.27\text{ V} \left(1 + \frac{R_6}{R_7} \right) \quad (15)$$

Example: A voltage of $V_{CVREF} = 3.3\text{ V}$ is to be set. Using Equation (15) the following ratio is provided for external resistors R_6 and R_7 :

$$\frac{R_6}{R_7} = \frac{V_{CVREF}}{V_{BG}} - 1 \approx 2.6 - 1 = 1.6$$

Example values of $R_7 = 10\text{ k}\Omega$ and $R_6 = 16\text{ k}\Omega$ are accrued for the resistors.

AM452 – Voltage-to-current transducer IC with a differential input

BLOCK DIAGRAM AND PINOUT

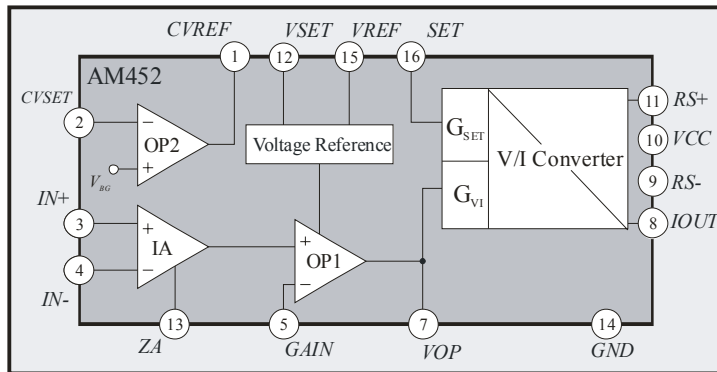

Figure 10: Simplified block diagram

PIN	NAME	EXPLANATION
1	CVREF	Current/Voltage reference
2	CVSET	Current/Voltage reference set
3	IN+	Positive input
4	IN-	Negative input
5	GAIN	Gain set
6	NC	Not connected
7	VOP	OP1 output
8	IOUT	Current output
9	RS-	Sensing resistor –
10	VCC	Supply voltage
11	RS+	Sensing resistor +
12	VSET	Reference voltage source set
13	ZA	Offset set
14	GND	IC ground
15	VREF	Reference voltage source output
16	SET	Output offset current set

Table 3: Pinout

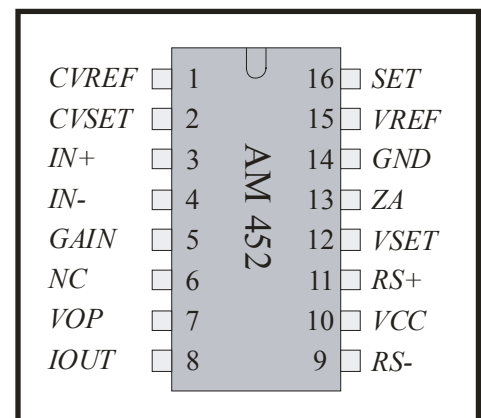

Figure 11: Pinout

Values which can be measured at the pins have indices; the pin name is written in capital letters.

AM452 – Voltage-to-current transducer IC with a differential input

DELIVERY

AM452 is available as an:

- SO16(n)

PACKAGE DIMENSIONS

Please see the data sheet on our website: package.pdf

FURTHER READING

- [1] The Frame ASIC concept: <http://www.Frame-ASIC.de/>

The following links refer to the Analog Microelectronics website:

<http://www.analogmicro.de/>

- [2] Technical article: *PR1012 – AM462 Voltage-to-current converter IC for 2-wire current loop applications*
- [3] Download: Kali_AM452.xls

NOTES

Analog Microelectronics reserves the right to make amendments to any dimensions, technical data or other information herein without further notice.