

Kingbright

3.0mmx1.0mm RIGHT ANGLE SMD CHIP LED LAMP

APBA3010SGNC

SUPER BRIGHT GREEN
PURE ORANGE

Features

- 3.0mmx1.0mm RIGHT ANGLE SMT LED, 2.0mm THICKNESS.
- LOW POWER CONSUMPTION.
- WIDE VIEWING ANGLE.
- IDEAL FOR BACKLIGHT AND INDICATOR.
- VARIOUS COLRS AND LENS TYPES AVAILABLE.
- PACKAGE : 2000PCS / REEL.

Description

The Super Bright Green source color devices are made with Gallium Phosphide Green Light Emitting Diode.

The Pure Orange source color devices are made with Gallium Arsenide Phosphide on Gallium Phosphide Pure Orange Light Emitting Diode.

Package Dimensions

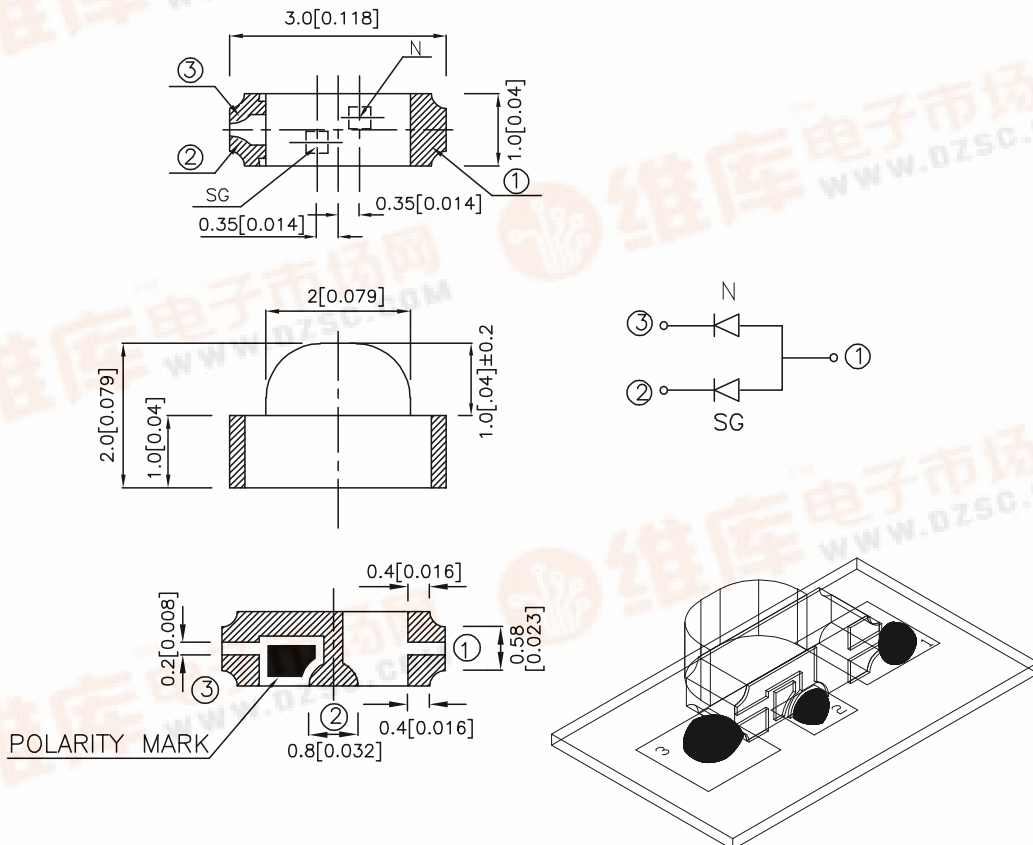

Notes:

1. All dimensions are in millimeters (inches).
2. Tolerance is $\pm 0.15(0.006)$ unless otherwise noted.
3. Specifications are subject to change without notice.

Selection Guide

Part No.	Dice	Lens Type	Iv (mcd) @ 20mA		Viewing Angle
			Min.	Typ.	θ1/2
APBA3010SGNC	SUPER BRIGHT GREEN (GaP)	WATER CLEAR	2.6	12	140°
	PURE ORANGE (GaAsP/GaP)		4	12	

Note:

1. θ1/2 is the angle from optical centerline where the luminous intensity is 1/2 the optical centerline value.

Electrical / Optical Characteristics at TA=25°C

Symbol	Parameter	Device	Typ.	Max.	Units	Test Conditions
λ _{peak}	Peak Wavelength	Super Bright Green Pure Orange	565 607		nm	I _F =20mA
λ _D	Dominate Wavelength	Super Bright Green Pure Orange	568 610		nm	I _F =20mA
Δλ _{1/2}	Spectral Line Half-width	Super Bright Green Pure Orange	30 35		nm	I _F =20mA
C	Capacitance	Super Bright Green Pure Orange	15 15		pF	V _F =0V;f=1MHz
V _F	Forward Voltage	Super Bright Green Pure Orange	2.2 2.05	2.5 2.5	V	I _F =20mA
I _R	Reverse Current	All		10	uA	V _R = 5V

Absolute Maximum Ratings at TA=25°C

Parameter	Super Bright Green	Pure Orange	Units
Power dissipation [2]	105	105	mW
DC Forward Current	25	25	mA
Peak Forward Current [1]	140	145	mA
Reverse Voltage	5	5	V
Operating / Storage Temperature	-40°C To +85°C		

Note:

1. 1/10 Duty Cycle, 0.1ms Pulse Width.

Kingbright

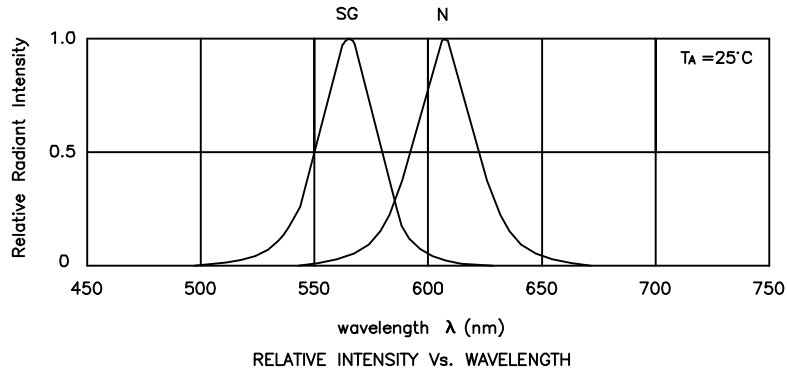

APBA3010SGNC Super Bright Green

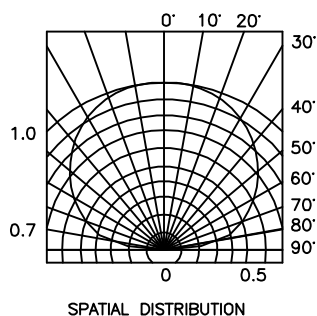
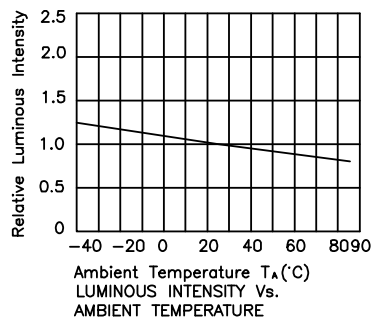
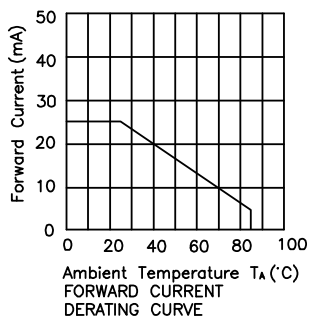
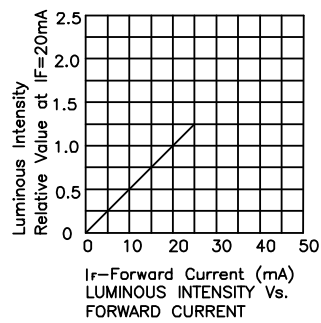
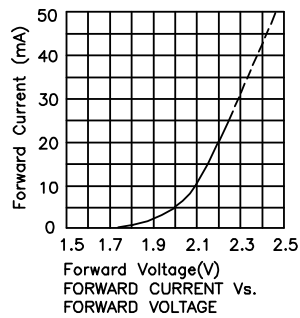

Kingbright

Pure Orange

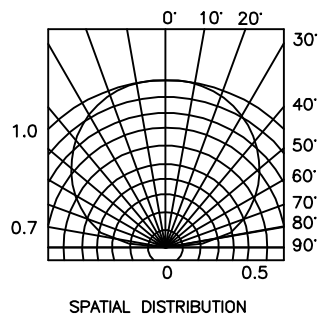
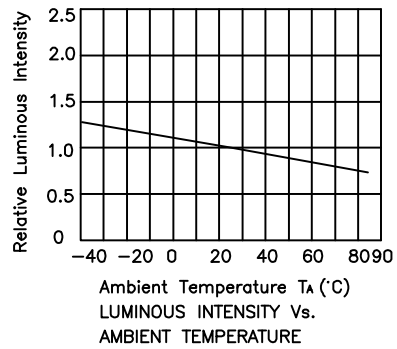
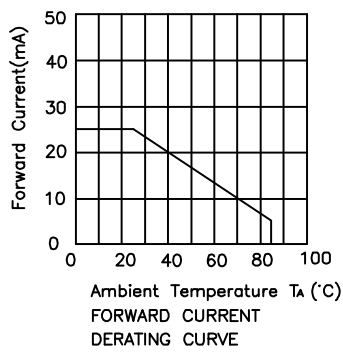
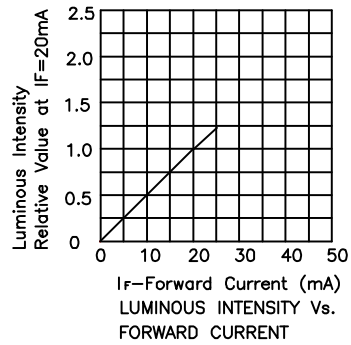
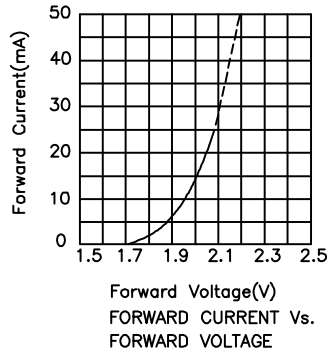

Kingbright

APBA3010SGNC SMT Reflow Soldering Instructions

Number of reflow process shall be less than 2 times and cooling process to normal temperature is required between first and second soldering process.

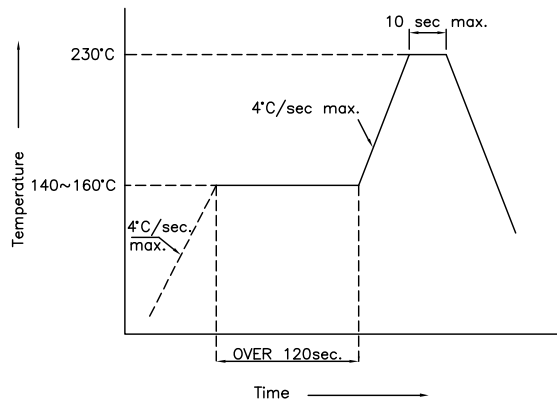

Recommended Soldering Pattern (Units : mm)

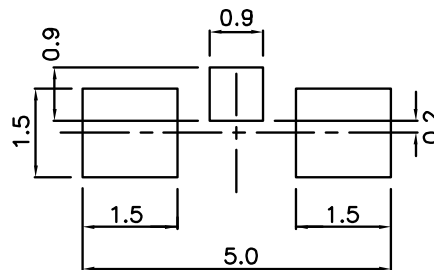

Tape Specifications (Units : mm)

