

Kingbright

3.0x2.5mm SURFACE MOUNT LED LAMP

APB3025NSGC-F01

PURE ORANGE

SUPER BRIGHT GREEN

Features

- 3.0mmx2.5mm SMT LED, 1.1mm THICKNESS.
- BI -COLOR,LOW POWER CONSUMPTION.
- WIDE VIEWING ANGLE.
- IDEAL FOR BACKLIGHT AND INDICATOR.
- VARIOUS COLORS AND LENS TYPES AVAILABLE.
- PACKAGE : 2000PCS / REEL.
- RoHS COMPLIANT.

Description

The Pure Orange source color devices are made with Gallium Arsenide Phosphide on Gallium Phosphide Pure Orange Light Emitting Diode.

The Super Bright Green source color devices are made with Gallium Phosphide Green Light Emitting Diode.

Package Dimensions

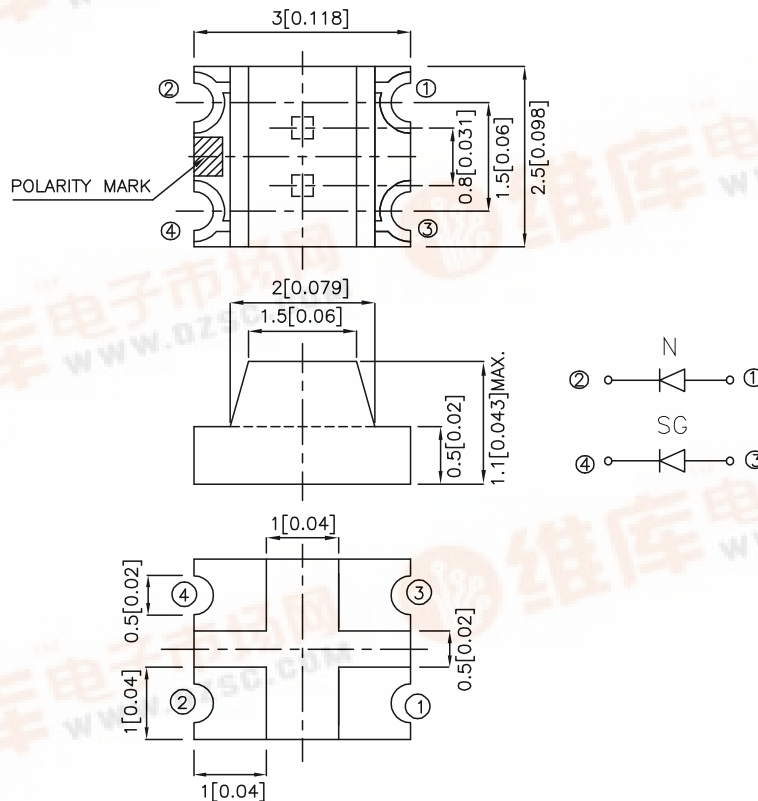

Notes:

1. All dimensions are in millimeters (inches).
2. Tolerance is $\pm 0.2(0.008)$ unless otherwise noted.
3. Specifications are subject to change without notice.

Selection Guide

Part No.	Dice	Lens Type	Iv (mcd) @ 20mA		Viewing Angle
			Min.	Typ.	2 θ 1/2
APB3025NSGC-F01	PURE ORANGE (GaAsP/GaP)	WATER CLEAR	4	12	120°
	SUPER BRIGHT GREEN (GaP)		4	12	

Note:

1. θ 1/2 is the angle from optical centerline where the luminous intensity is 1/2 the optical centerline value.

Electrical / Optical Characteristics at TA=25°C

Symbol	Parameter	Device	Typ.	Max.	Units	Test Conditions
λ_{peak}	Peak Wavelength	Pure Orange Super Bright Green	607 565		nm	IF=20mA
λ_D	Dominant Wavelength	Pure Orange Super Bright Green	610 568		nm	IF=20mA
$\Delta\lambda_{1/2}$	Spectral Line Half-width	Pure Orange Super Bright Green	35 30		nm	IF=20mA
C	Capacitance	Pure Orange Super Bright Green	15 15		pF	VF=0V;f=1MHz
VF	Forward Voltage	Pure Orange Super Bright Green	2.05 2.2	2.5 2.5	V	IF=20mA
IR	Reverse Current	All		10	uA	VR = 5V

Absolute Maximum Ratings at TA=25°C

Parameter	Pure Orange	Super Bright Green	Units
Power dissipation	105	105	mW
DC Forward Current	25	25	mA
Peak Forward Current [1]	145	140	mA
Reverse Voltage	5		V
Operating/Storage Temperature	-40°C To +85°C		

Note:

1. 1/10 Duty Cycle, 0.1ms Pulse Width.

Kingbright

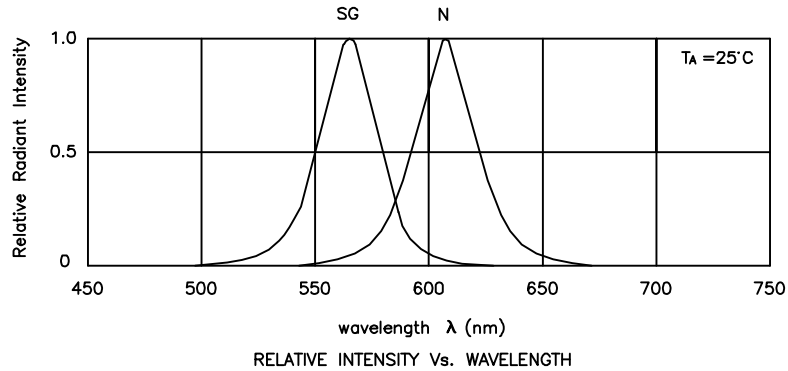

APB3025NSGC-F01 Pure Orange

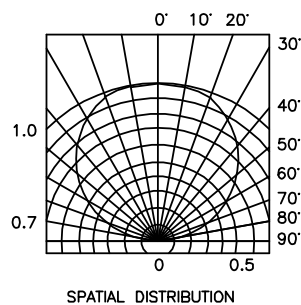
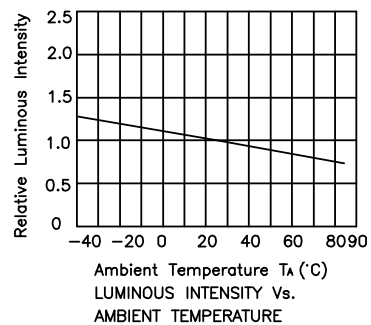
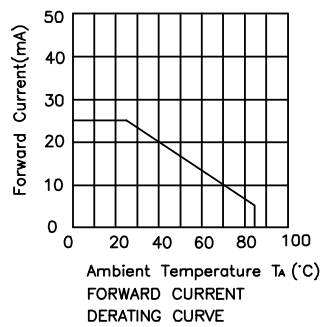
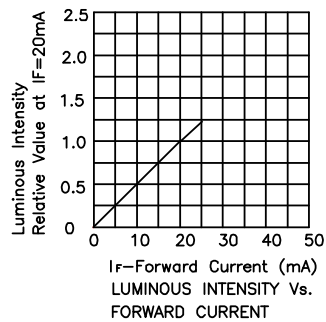
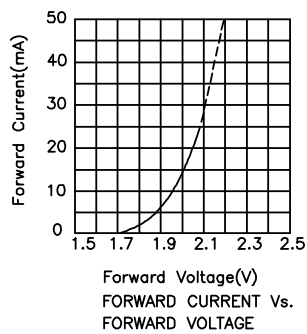

Kingbright

Super Bright Green

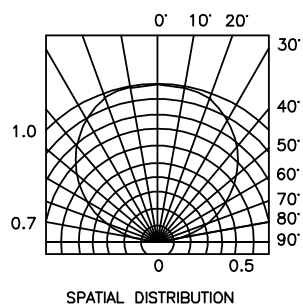
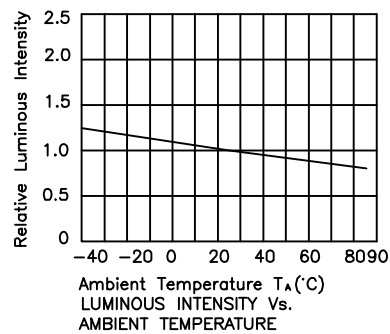
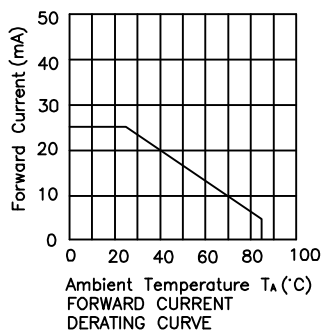
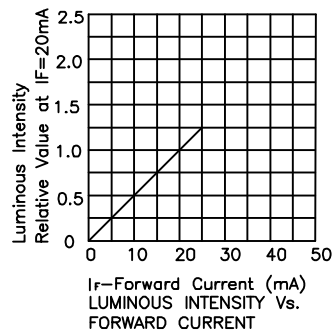
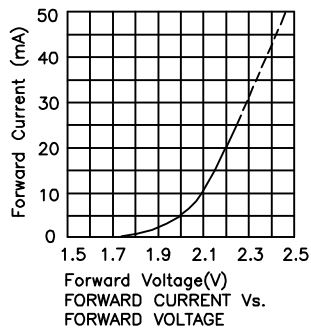

APB3025NSGC-F01

Reflow Soldering Profile For Lead-free SMT Process.

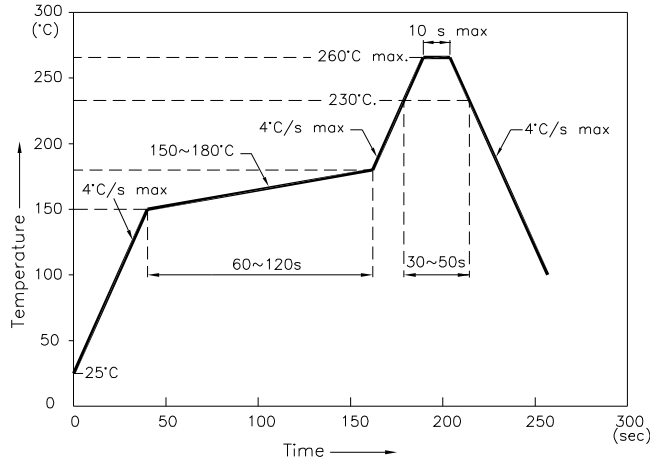

NOTES:

1. We recommend the reflow temperature 245°C(+/-5°C). The maximum soldering temperature should be limited to 260°C.
2. Don't cause stress to the epoxy resin while it is exposed to high temperature.
3. Number of reflow process shall be 2 times or less.

Recommended Soldering Pattern (Units : mm)

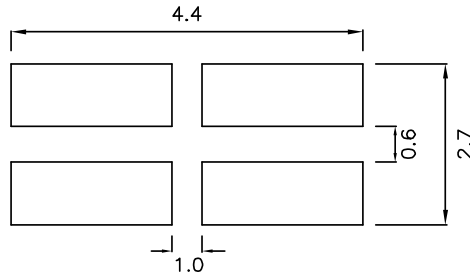

Tape Specifications (Units : mm)

