

Kingbright

3.0x2.5mm SURFACE MOUNT LED LAMP

APKB3025SURKMGK-F01

HYPER RED
MEGA GREEN

Features

- 3.0mmx2.5mm SMT LED, 1.3mm THICKNESS.
- BI-COLOR,LOW POWER CONSUMPTION.
- WIDE VIEWING ANGLE.
- IDEAL FOR BACKLIGHT AND INDICATOR.
- VARIOUS COLORS AND LENS TYPES AVAILABLE.
- PACKAGE : 2000PCS / REEL.
- RoHS COMPLIANT.

Description

The Hyper Red source color devices are made with DH InGaAlP on GaAs substrate Light Emitting Diode.

The Mega Green source color devices are made with DH InGaAlP on GaAs substrate Light Emitting Diode.

Package Dimensions

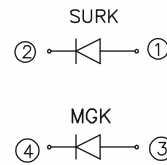
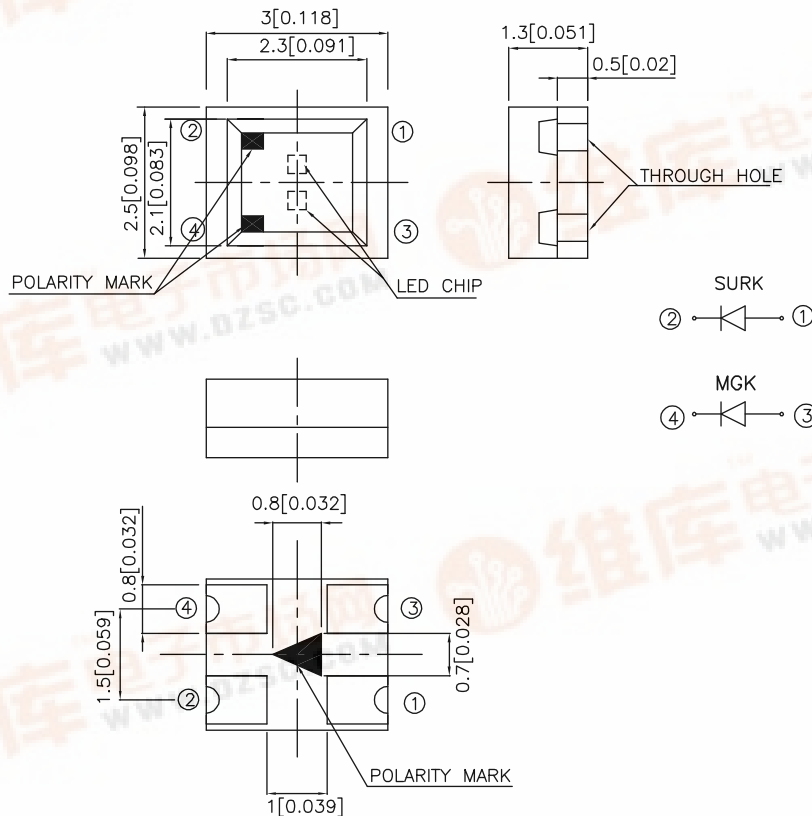

Notes:

1. All dimensions are in millimeters (inches).
2. Tolerance is $\pm 0.2(0.0079)$ unless otherwise noted.
3. Specifications are subject to change without notice.

Kingbright

Selection Guide

Part No.	Dice	Lens Type	Iv (mcd) @ 20mA		Viewing Angle
			Min.	Typ.	2 θ 1/2
APKB3025SURKMGK-F01	HYPHER RED (InGaAlP)	WATER CLEAR	70	150	120°
	MEGA GREEN (InGaAlP)		10	50	

Note:

1. θ1/2 is the angle from optical centerline where the luminous intensity is 1/2 the optical centerline value.

Electrical / Optical Characteristics at TA=25°C

Symbol	Parameter	Device	Typ.	Max.	Units	Test Conditions
λpeak	Peak Wavelength	Hyper Red Mega Green	650 574		nm	IF=20mA
λD	Dominant Wavelength	Hyper Red Mega Green	635 570		nm	IF=20mA
Δλ1/2	Spectral Line Half-width	Hyper Red Mega Green	28 20		nm	IF=20mA
C	Capacitance	Hyper Red Mega Green	35 15		pF	VF=0V;f=1MHz
VF	Forward Voltage	Hyper Red Mega Green	1.95 2.1	2.5 2.5	V	IF=20mA
IR	Reverse Current	All		10	uA	VR = 5V

Absolute Maximum Ratings at TA=25°C

Parameter	Hyper Red	Mega Green	Units
Power dissipation	170	105	mW
DC Forward Current	30	30	mA
Peak Forward Current [1]	185	150	mA
Reverse Voltage	5		V
Operating/Storage Temperature	-40°C To +85°C		

Note:

1. 1/10 Duty Cycle, 0.1ms Pulse Width.

Kingbright

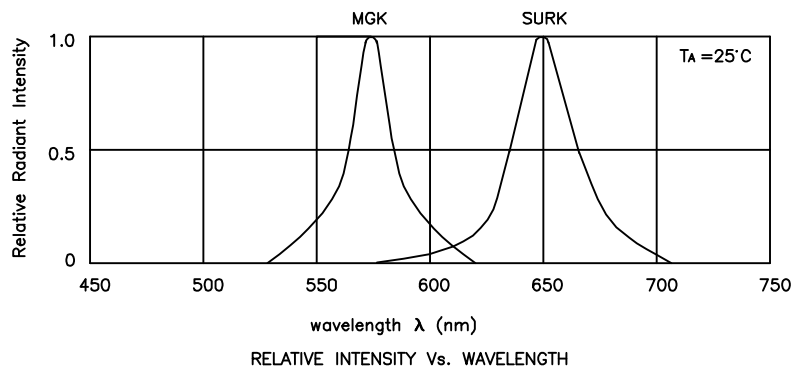

APKB3025SURKMGK-F01 Hyper Red

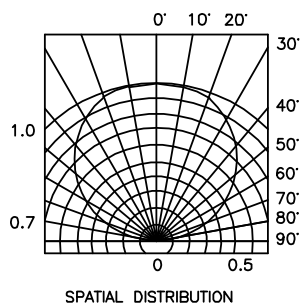
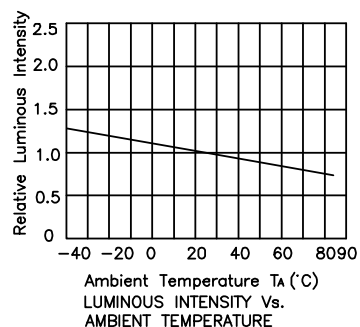
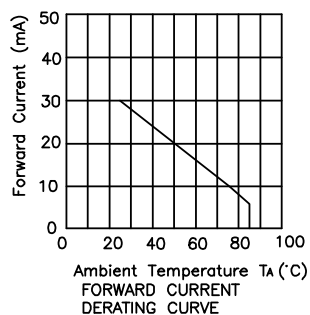
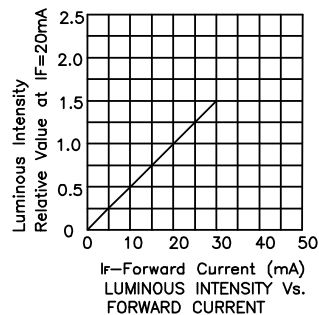
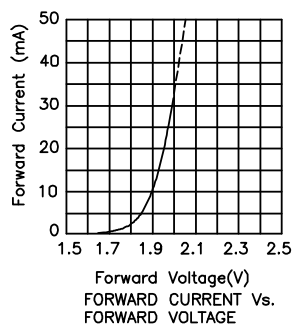

Kingbright

Mega Green

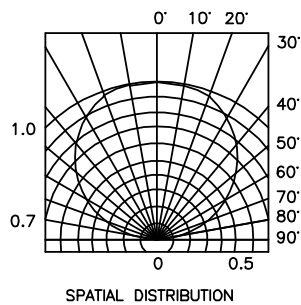
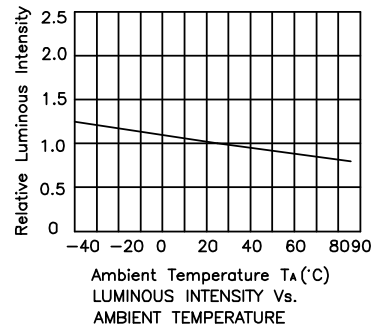
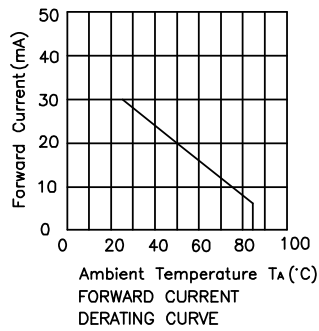
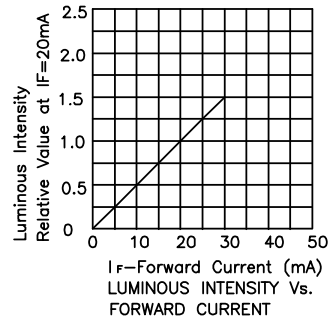
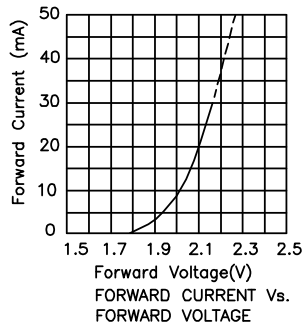

APKB3025SURKMGK-F01

Reflow Soldering Profile For Lead-free SMT Process.

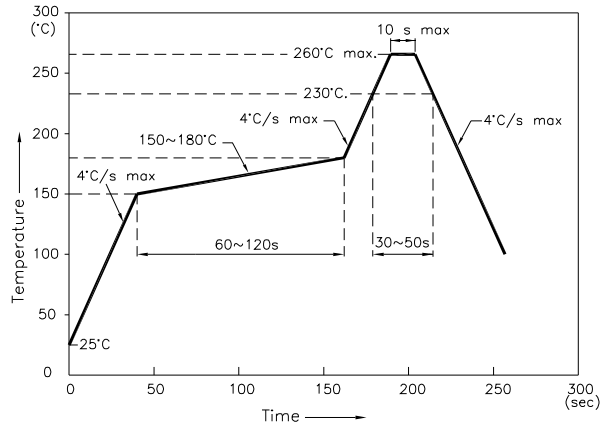

NOTES:

1. We recommend the reflow temperature 245°C(+/-5°C). The maximum soldering temperature should be limited to 260°C.
2. Don't cause stress to the epoxy resin while it is exposed to high temperature.
3. Number of reflow process shall be 2 times or less.

Recommended Soldering Pattern (Units : mm)

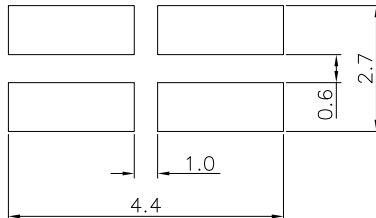

Tape Specifications (Units : mm)

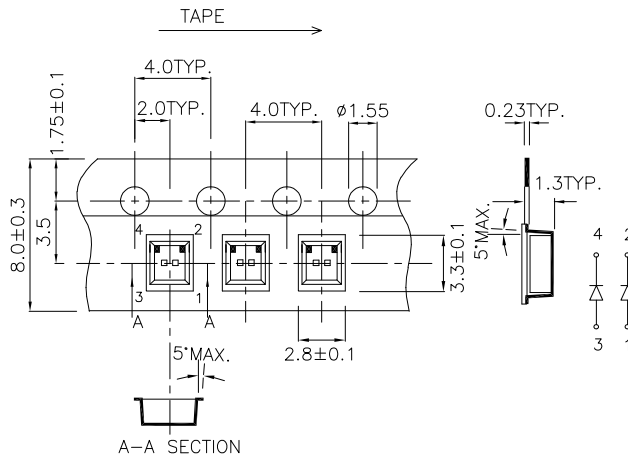

Remarks:

If special sorting is required (e.g. binning based on forward voltage, luminous intensity, or wavelength), the typical accuracy of the sorting process is as follows:

1. Wavelength: +/-1nm
2. Luminous Intensity: +/-15%
3. Forward Voltage: +/-0.1V

Note: Accuracy may depend on the sorting parameters.