



# APT38M50J

500V, 38A, 0.10Ω Max

## N-Channel MOSFET

Power MOS 8™ is a high speed, high voltage N-channel switch-mode power MOSFET. A proprietary planar stripe design yields excellent reliability and manufacturability. Low switching loss is achieved with low input capacitance and ultra low  $C_{rss}$  "Miller" capacitance. The intrinsic gate resistance and capacitance of the poly-silicon gate structure help control slew rates during switching, resulting in low EMI and reliable paralleling, even when switching at very high frequency. Reliability in flyback, boost, forward, and other circuits is enhanced by the high avalanche energy capability.

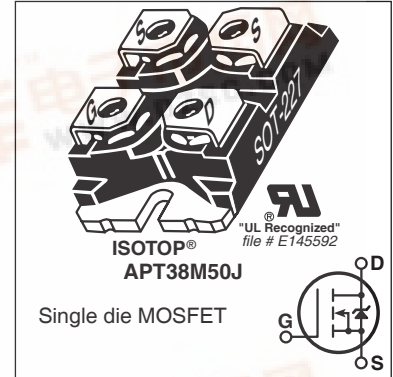

### FEATURES

- Fast switching with low EMI/RFI
- Low  $R_{DS(on)}$
- Ultra low  $C_{rss}$  for improved noise immunity
- Low gate charge
- Avalanche energy rated
- RoHS compliant

### TYPICAL APPLICATIONS

- PFC and other boost converter
- Buck converter
- Two switch forward (asymmetrical bridge)
- Single switch forward
- Flyback
- Inverters

### Absolute Maximum Ratings

Symbol	Parameter	Ratings	Unit
$I_D$	Continuous Drain Current @ $T_C = 25^\circ\text{C}$	38	A
	Continuous Drain Current @ $T_C = 100^\circ\text{C}$	24	
$I_{DM}$	Pulsed Drain Current <sup>①</sup>	175	
$V_{GS}$	Gate-Source Voltage	±30	V
$E_{AS}$	Single Pulse Avalanche Energy <sup>②</sup>	1200	mJ
$I_{AR}$	Avalanche Current, Repetitive or Non-Repetitive	28	A

### Thermal and Mechanical Characteristics

Symbol	Characteristic	Min	Typ	Max	Unit
$P_D$	Total Power Dissipation @ $T_C = 25^\circ\text{C}$			357	W
$R_{\theta JC}$	Junction to Case Thermal Resistance			0.35	°C/W
$R_{\theta CS}$	Case to Sink Thermal Resistance, Flat, Greased Surface		0.15		
$T_J, T_{STG}$	Operating and Storage Junction Temperature Range	-55		150	°C
$V_{Isolation}$	RMS Voltage (50-60Hz Sinusoidal Waveform from Terminals to Mounting Base for 1 Min.)	2500			V
$W_T$	Package Weight		1.03		oz
			29.2		g
Torque	Terminals and Mounting Screws.			10	in-lbf
				1.1	N·m

### Static Characteristics

$T_J = 25^\circ\text{C}$  unless otherwise specified

APT38M50J

Symbol	Parameter	Test Conditions	Min	Typ	Max	Unit
$V_{BR(DSS)}$	Drain-Source Breakdown Voltage	$V_{GS} = 0V, I_D = 250\mu A$	500			V
$\Delta V_{BR(DSS)}/\Delta T_J$	Breakdown Voltage Temperature Coefficient	Reference to $25^\circ\text{C}, I_D = 250\mu A$		0.60		V/ $^\circ\text{C}$
$R_{DS(on)}$	Drain-Source On Resistance <sup>③</sup>	$V_{GS} = 10V, I_D = 28A$		0.085	0.10	$\Omega$
$V_{GS(th)}$	Gate-Source Threshold Voltage	$V_{GS} = V_{DS}, I_D = 2.5mA$	3	4	5	V
$\Delta V_{GS(th)}/\Delta T_J$	Threshold Voltage Temperature Coefficient			-10		mV/ $^\circ\text{C}$
$I_{DSS}$	Zero Gate Voltage Drain Current	$V_{DS} = 500V$ $V_{GS} = 0V$			100	$\mu A$
		$T_J = 25^\circ\text{C}$ $T_J = 125^\circ\text{C}$			500	
$I_{GSS}$	Gate-Source Leakage Current	$V_{GS} = \pm 30V$			$\pm 100$	nA

### Dynamic Characteristics

$T_J = 25^\circ\text{C}$  unless otherwise specified

Symbol	Parameter	Test Conditions	Min	Typ	Max	Unit
$g_{fs}$	Forward Transconductance	$V_{DS} = 50V, I_D = 28A$		42		S
$C_{iss}$	Input Capacitance	$V_{GS} = 0V, V_{DS} = 25V$ $f = 1MHz$		8800		pF
$C_{rss}$	Reverse Transfer Capacitance			120		
$C_{oss}$	Output Capacitance			945		
$C_{o(cr)}$ <sup>④</sup>	Effective Output Capacitance, Charge Related	$V_{GS} = 0V, V_{DS} = 0V$ to 333V		550		pF
$C_{o(er)}$ <sup>⑤</sup>	Effective Output Capacitance, Energy Related			275		
$Q_g$	Total Gate Charge	$V_{GS} = 0$ to 10V, $I_D = 28A$ , $V_{DS} = 250V$		220		nC
$Q_{gs}$	Gate-Source Charge			50		
$Q_{gd}$	Gate-Drain Charge			100		
$t_{d(on)}$	Turn-On Delay Time	<b>Resistive Switching</b> $V_{DD} = 333V, I_D = 28A$ $R_G = 4.7\Omega$ <sup>⑥</sup> , $V_{GG} = 15V$		38		ns
$t_r$	Current Rise Time			45		
$t_{d(off)}$	Turn-Off Delay Time			100		
$t_f$	Current Fall Time			33		

### Source-Drain Diode Characteristics

Symbol	Parameter	Test Conditions	Min	Typ	Max	Unit
$I_S$	Continuous Source Current (Body Diode)	MOSFET symbol showing the integral reverse p-n junction diode (body diode)			38	A
$I_{SM}$	Pulsed Source Current (Body Diode) <sup>①</sup>				175	
$V_{SD}$	Diode Forward Voltage	$I_{SD} = 28A, T_J = 25^\circ\text{C}, V_{GS} = 0V$			1	V
$t_{rr}$	Reverse Recovery Time	$I_{SD} = 28A$ <sup>②</sup>		660		ns
$Q_{rr}$	Reverse Recovery Charge	$di_{SD}/dt = 100A/\mu s, T_J = 25^\circ\text{C}$		13.2		$\mu C$
dv/dt	Peak Recovery dv/dt	$I_{SD} \leq 28A, di/dt \leq 1000A/\mu s, V_{DD} = 333V, T_J = 125^\circ\text{C}$			8	V/ns

- ① Repetitive Rating: Pulse width and case temperature limited by maximum junction temperature.
- ② Starting at  $T_J = 25^\circ\text{C}$ ,  $L = 3.06mH$ ,  $R_G = 4.7\Omega$ ,  $I_{AS} = 28A$ .
- ③ Pulse test: Pulse Width < 380 $\mu s$ , duty cycle < 2%.
- ④  $C_{o(cr)}$  is defined as a fixed capacitance with the same stored charge as  $C_{OSS}$  with  $V_{DS} = 67\%$  of  $V_{(BR)DSS}$ .
- ⑤  $C_{o(er)}$  is defined as a fixed capacitance with the same stored energy as  $C_{OSS}$  with  $V_{DS} = 67\%$  of  $V_{(BR)DSS}$ . To calculate  $C_{o(er)}$  for any value of  $V_{DS}$  less than  $V_{(BR)DSS}$ , use this equation:  $C_{o(er)} = -2.04E-7/V_{DS}^2 + 4.76E-8/V_{DS} + 1.36E-10$ .
- ⑥  $R_G$  is external gate resistance, not including internal gate resistance or gate driver impedance. (MIC4452)

Microsemi reserves the right to change, without notice, the specifications and information contained herein.

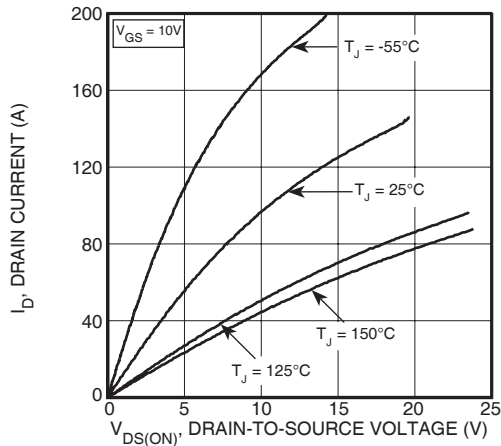

Figure 1, Output Characteristics

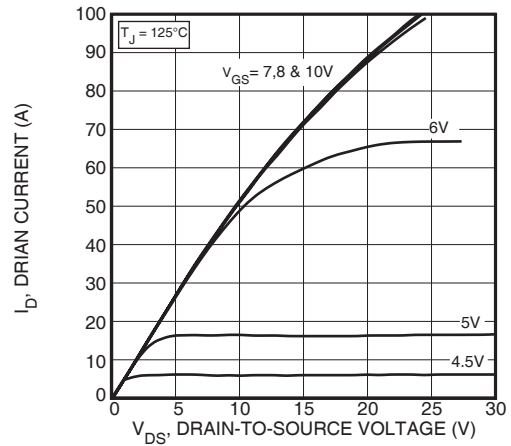

Figure 2, Output Characteristics

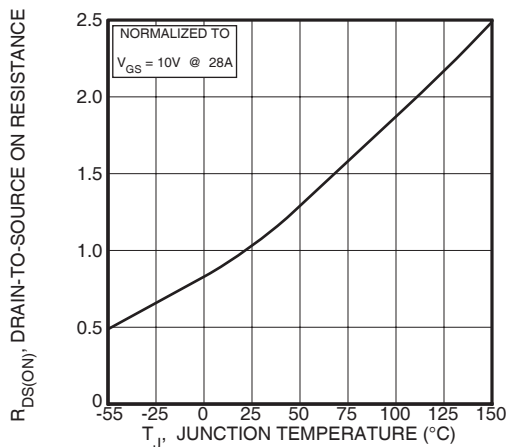

Figure 3,  $R_{DS(ON)}$  vs Junction Temperature

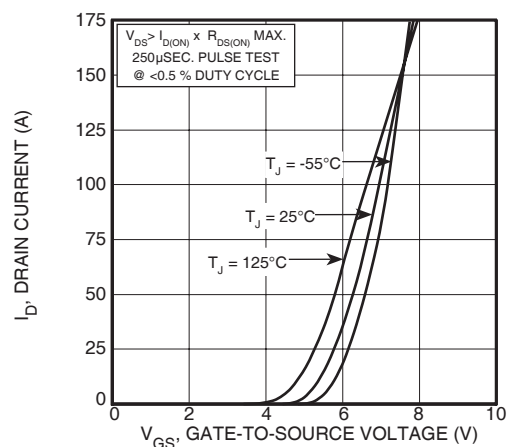

Figure 4, Transfer Characteristics

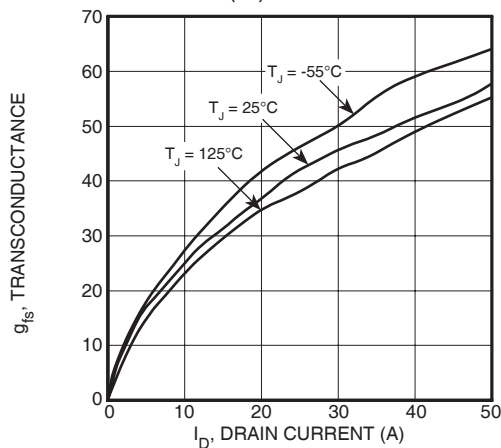

Figure 5, Gain vs Drain Current

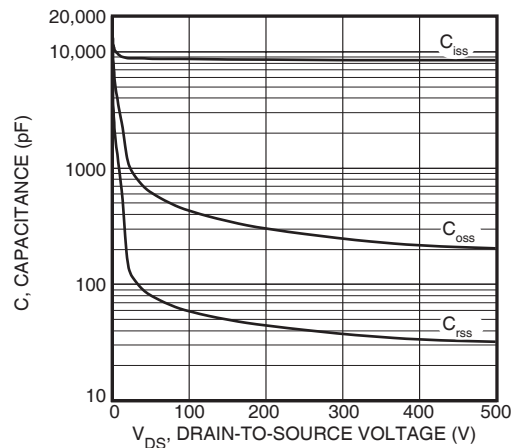

Figure 6, Capacitance vs Drain-to-Source Voltage

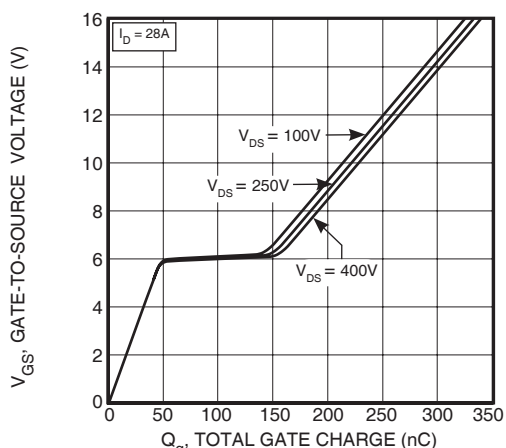

Figure 7, Gate Charge vs Gate-to-Source Voltage

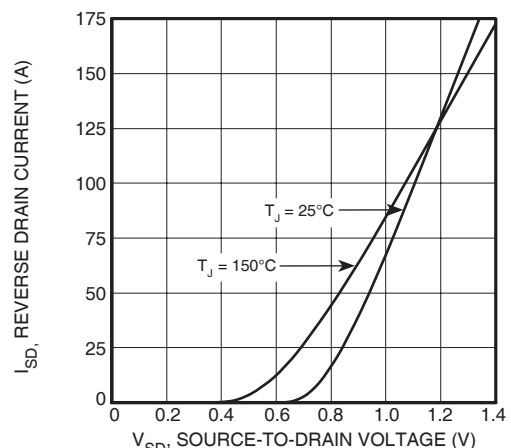

Figure 8, Reverse Drain Current vs Source-to-Drain Voltage

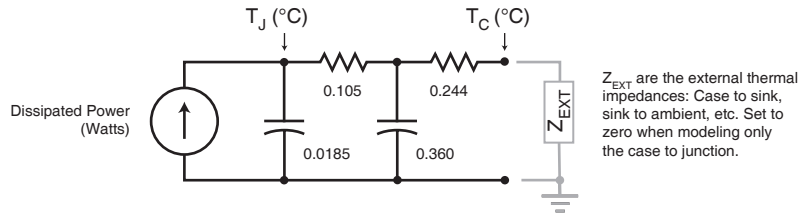
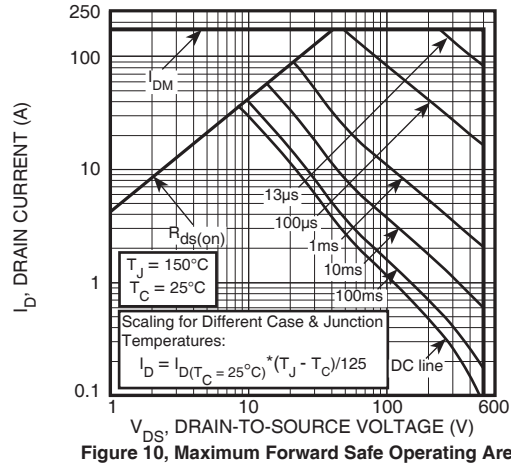
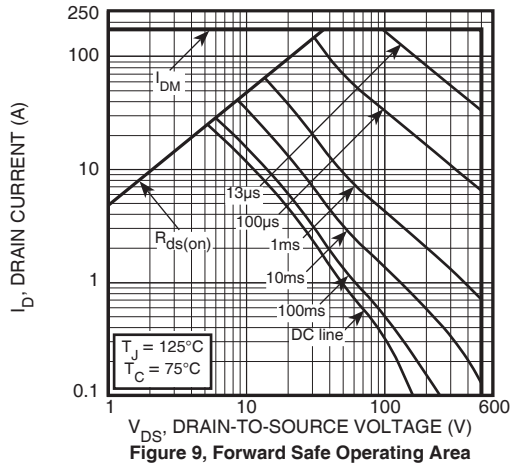

Figure 11, Transient Thermal Impedance Model

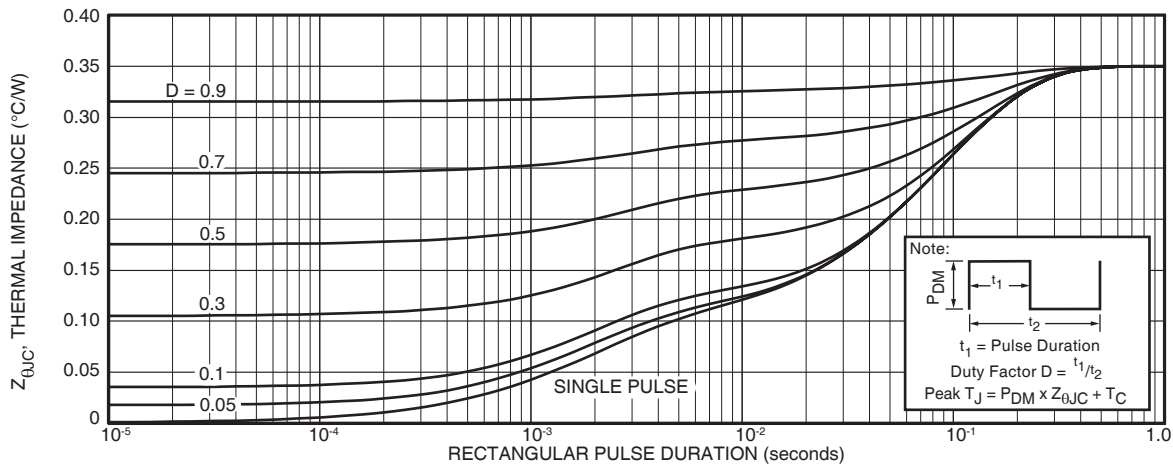

Figure 12. Maximum Effective Transient Thermal Impedance Junction-to-Case vs Pulse Duration

SOT-227 (ISOTOP®) Package Outline

