

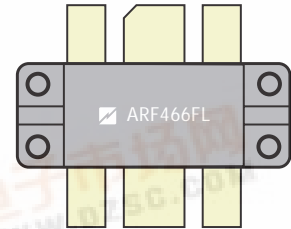

# ARF466FL

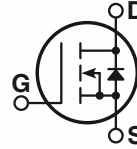

## RF POWER MOSFETS

### N-CHANNEL ENHANCEMENT MODE

**200V 300W 45MHz**

The ARF466FL is a rugged high voltage RF power transistor designed for scientific, commercial, medical and industrial RF power amplifier applications up to 45 MHz. It has been optimized for both linear and high efficiency classes of operation.

- Specified 150 Volt, 40.68 MHz Characteristics:
  - Output Power = 300 Watts.
  - Gain = 16dB (Class AB)
  - Efficiency = 75% (Class C)
- Low Cost Flangeless RF Package.
- Low Vth thermal coefficient.
- Low Thermal Resistance.
- Optimized SOA for Superior Ruggedness.

#### MAXIMUM RATINGS

All Ratings:  $T_C = 25^\circ\text{C}$  unless otherwise specified.

Symbol	Parameter	ARF466FL	UNIT
$V_{DSS}$	Drain-Source Voltage	1000	Volts
$V_{DGO}$	Drain-Gate Voltage	1000	
$I_D$	Continuous Drain Current @ $T_C = 25^\circ\text{C}$	13	Amps
$V_{GS}$	Gate-Source Voltage	$\pm 30$	Volts
$P_D$	Total Power Dissipation @ $T_C = 25^\circ\text{C}$	450	Watts
$R_{\theta JC}$	Junction to Case	0.30	$^\circ\text{C}/\text{W}$
$T_J, T_{STG}$	Operating and Storage Junction Temperature Range	-55 to 175	$^\circ\text{C}$
$T_L$	Lead Temperature: 0.063" from Case for 10 Sec.	300	

#### STATIC ELECTRICAL CHARACTERISTICS

Symbol	Characteristic / Test Conditions	MIN	TYP	MAX	UNIT
$BV_{DSS}$	Drain-Source Breakdown Voltage ( $V_{GS} = 0\text{V}, I_D = 250 \mu\text{A}$ )	1000			Volts
$R_{DS(ON)}$	Drain-Source On-State Resistance <sup>①</sup> ( $V_{GS} = 10\text{V}, I_D = 6.5\text{A}$ )			0.90	ohms
$I_{DSS}$	Zero Gate Voltage Drain Current ( $V_{DS} = 1000\text{V}, V_{GS} = 0\text{V}$ )			25	$\mu\text{A}$
	Zero Gate Voltage Drain Current ( $V_{DS} = 800\text{V}, V_{GS} = 0\text{V}, T_C = 125^\circ\text{C}$ )			250	
$I_{GSS}$	Gate-Source Leakage Current ( $V_{GS} = \pm 30\text{V}, V_{DS} = 0\text{V}$ )			$\pm 100$	nA
$g_{fs}$	Forward Transconductance ( $V_{DS} = 25\text{V}, I_D = 6.5\text{A}$ )	3.3	7	9	mhos
$V_{GS(TH)}$	Gate Threshold Voltage ( $V_{DS} = V_{GS}, I_D = 1\text{mA}$ )	2		4	Volts

**CAUTION:** These Devices are Sensitive to Electrostatic Discharge. Proper Handling Procedures Should Be Followed.

### DYNAMIC CHARACTERISTICS

ARF466FL

Symbol	Characteristic	Test Conditions	MIN	TYP	MAX	UNIT
$C_{iss}$	Input Capacitance	$V_{GS} = 0V$ $V_{DS} = 150V$ $f = 1\text{ MHz}$		2000		pF
$C_{oss}$	Output Capacitance			165		
$C_{rss}$	Reverse Transfer Capacitance			75		
$t_{d(on)}$	Turn-on Delay Time	$V_{GS} = 15V$ $V_{DD} = 500\text{ V}$ $I_D = 13A @ 25^\circ C$ $R_G = 1.6\Omega$		12		ns
$t_r$	Rise Time			10		
$t_{d(off)}$	Turn-off Delay Time			43		
$t_f$	Fall Time			10		

### FUNCTIONAL CHARACTERISTICS

Symbol	Characteristic	Test Conditions	MIN	TYP	MAX	UNIT
$G_{PS}$	Common Source Amplifier Power Gain	$f = 40.68\text{ MHz}$	14	16		dB
$\eta$	Drain Efficiency	$V_{GS} = 2.5V$ $V_{DD} = 150V$	70	75		%
$\psi$	Electrical Ruggedness VSWR 10:1	$P_{out} = 300W$	No Degradation in Output Power			

① Pulse Test: Pulse width < 380μS, Duty Cycle < 2%

APT Reserves the right to change, without notice, the specifications and information contained herein.

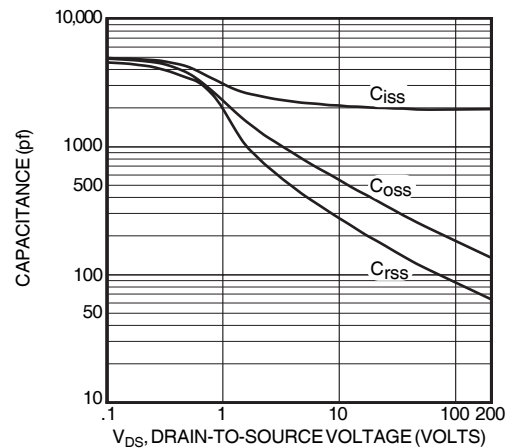

Figure 2, Typical Capacitance vs. Drain-to-Source Voltage

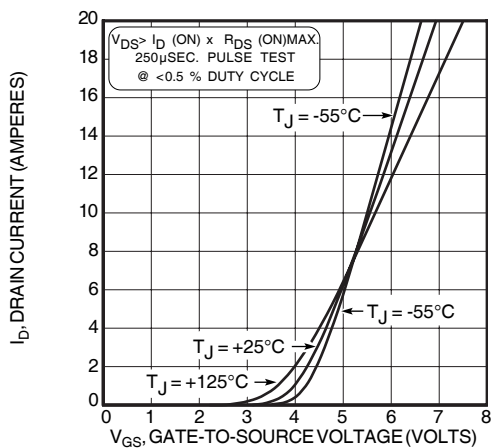

Figure 3, Typical Transfer Characteristics

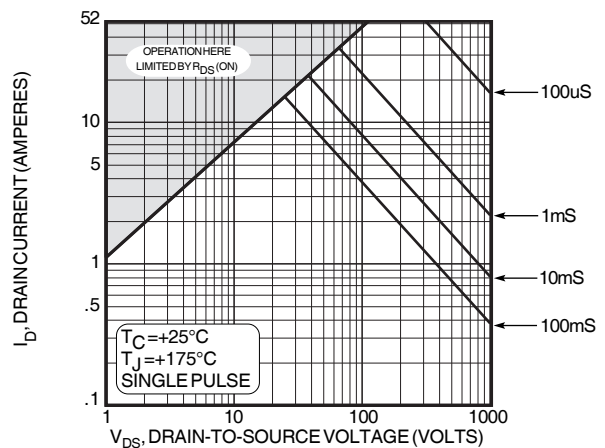

Figure 4, Typical Maximum Safe Operating Area

**TYPICAL PERFORMANCE CURVES**

ARF466FL

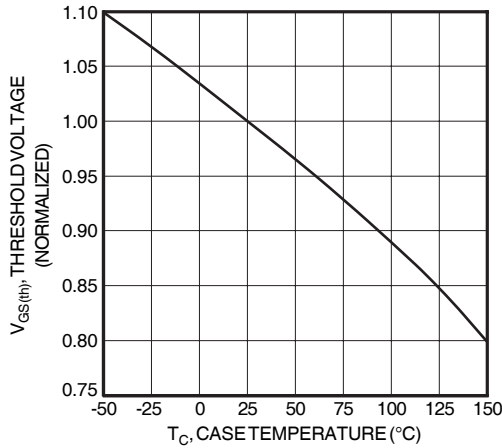

Figure 5, Typical Threshold Voltage vs Temperature

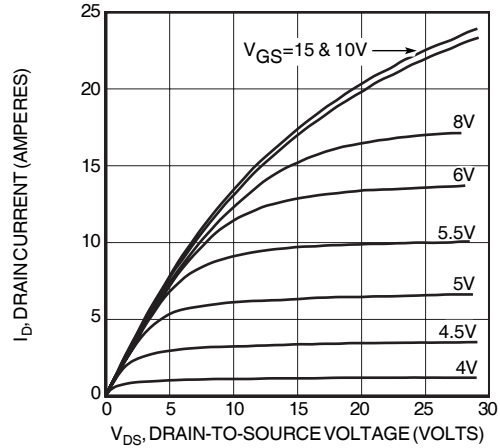

Figure 6, Typical Output Characteristics

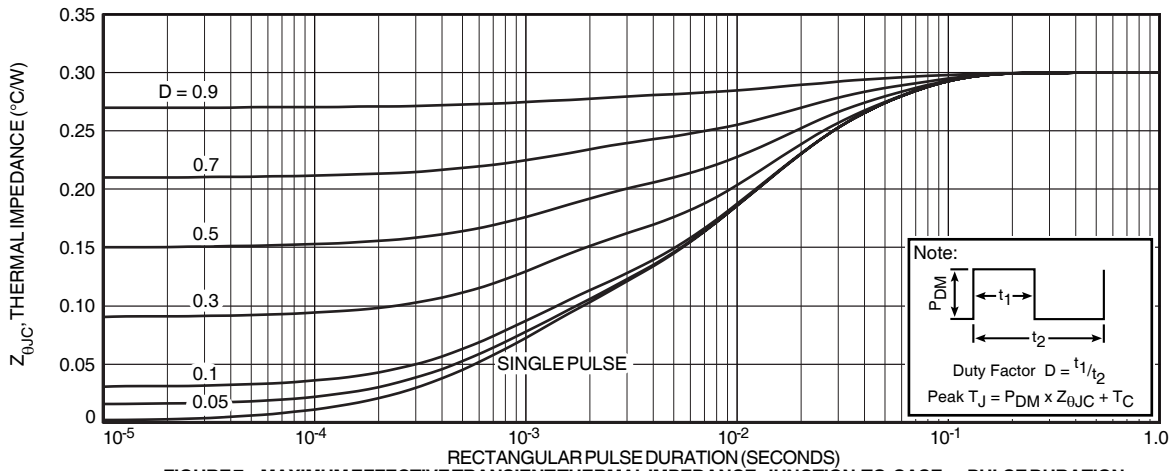

FIGURE 7a, MAXIMUM EFFECTIVE TRANSIENT THERMAL IMPEDANCE, JUNCTION-TO-CASE vs PULSE DURATION

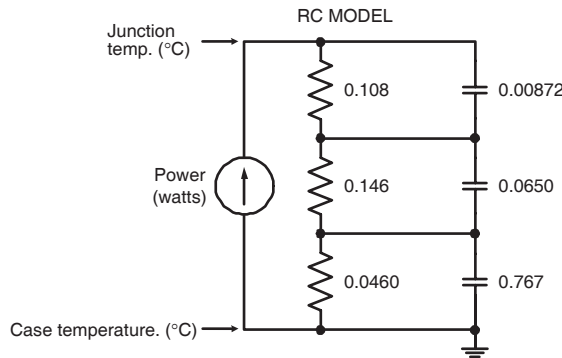

Figure 7b, TRANSIENT THERMAL IMPEDANCE MODEL

Table 1 - Typical Class AB Large Signal Input - Output Impedance

Freq. (MHz)	Z <sub>IN</sub> (Ω)	Z <sub>OL</sub> (Ω)
2.0	18 - j 11	30 - j 1.7
13.5	1.3 - j 5	25.7 - j 9.8
27.1	.40 - j 2.6	18 - j 13.3
40.7	.20 - j 1.6	12 - j 12.6
65	.11 + j 0.6	6.2 - j 8.9

Z<sub>in</sub> - Gate shunted with 25Ω

I<sub>DQ</sub> = 100mA

Z<sub>OL</sub> - Coniugate of optimum load for 300 W output at V<sub>dd</sub> = 150V

## 40.68 MHz Test Circuit

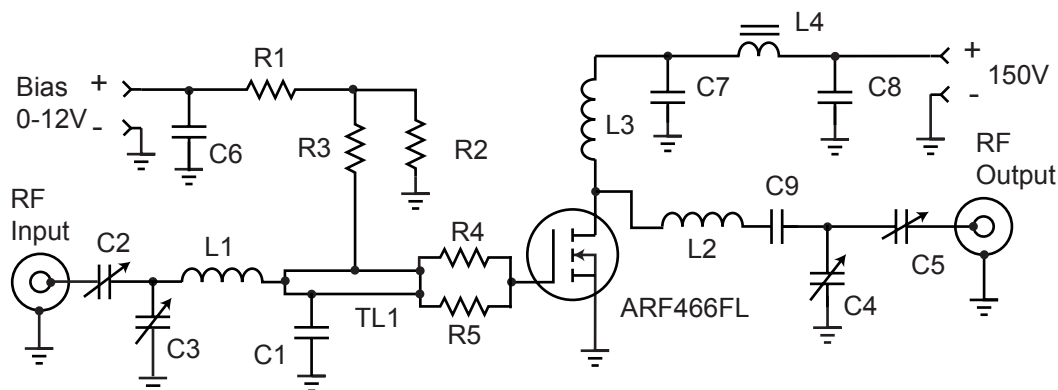

C1 -- 2200pF ATC 700B

C2-C5 -- Arco 465 Mica trimmer

C6-C8 -- .1mF 500V ceramic chip

C9 -- 3x 2200pF 500V chips COG

L1 -- 3t #22 AWG .25"ID .25 "L ~55nH

L2 -- 5t #16 AWG .312" ID .35"L ~176nH

L3 -- 10t #24 AWG .25"ID ~.5uH

L4 -- VK200-4B ferrite choke 3uH

R1- R3 -- 1k $\Omega$  0.5WR4- R5 -- 1 $\Omega$  1W SMTTL1 -- 40 $\Omega$  t-line 0.15 x 2"

C1 is ~1.75" from R4-5.

## T3 Package Outline

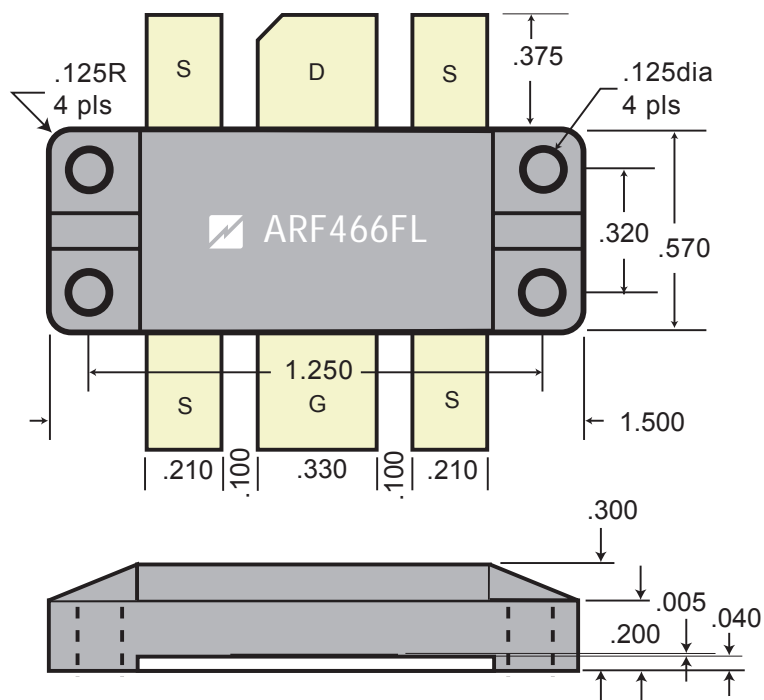

## Thermal Considerations and Package Mounting:

The rated power dissipation is only available when the package mounting surface is at 25°C and the junction temperature is 175°C. The thermal resistance between junctions and case mounting surface is 0.3°C/W. When installed, an additional thermal impedance of 0.1°C/W between the package base and the mounting surface is typical. Insure that the mounting surface is smooth and flat. Thermal joint compound must be used to reduce the effects of small surface irregularities. Use the minimum amount necessary to coat the surface. The heatsink should incorporate a copper heat spreader to obtain best results.

The package design clamps the ceramic base to the heatsink. A clamped joint maintains the required mounting pressure while allowing for thermal expansion of both the base and the heat sink. Four 4-40 (M3) screws provide the required mounting force. Torque the mounting screws to 6 in-lb (0.68 N-m).