



PRELIMINARY DATA SHEET

# AP147-320: ISM 900 MHz Band 2-Watt InGaP HBT Power Amplifier

## Features

- 902–928 MHz operation
- Output power greater than 33 dBm
- 3.2 V nominal operating voltage
- Integrated analog power control voltage,  $V_{APC} = 0.1\text{--}2.8\text{ V}$
- High PAE of 50% at maximum output power
- Ultrasmall, thermally enhanced micro lead frame package.
- Low current in standby mode of  $< 10\ \mu\text{A}$
- Available on tape and reel

## Description

The AP147-320 is a high-performance 3-stage, high-power amplifier IC designed for use in 900 MHz ISM band applications such as automatic meter readers and RFID. It has an integrated analog power control voltage for achieving the desired output power levels. The IC is manufactured on an advanced InGaP HBT process. The AP147-320 is packaged in a thermally enhanced, ultrasmall, micro lead frame package.

## Block Diagram

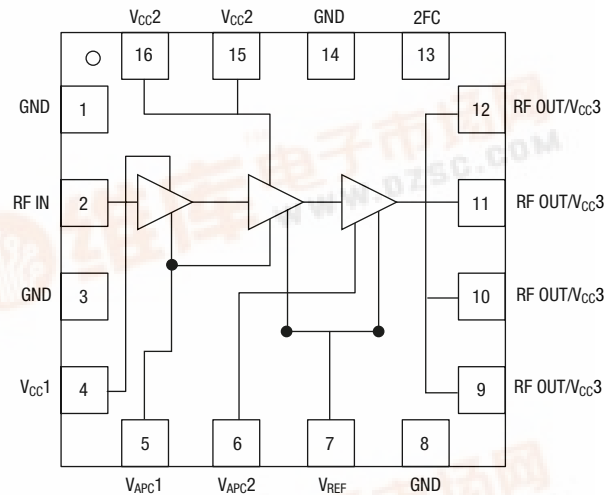

## Package Dimensions

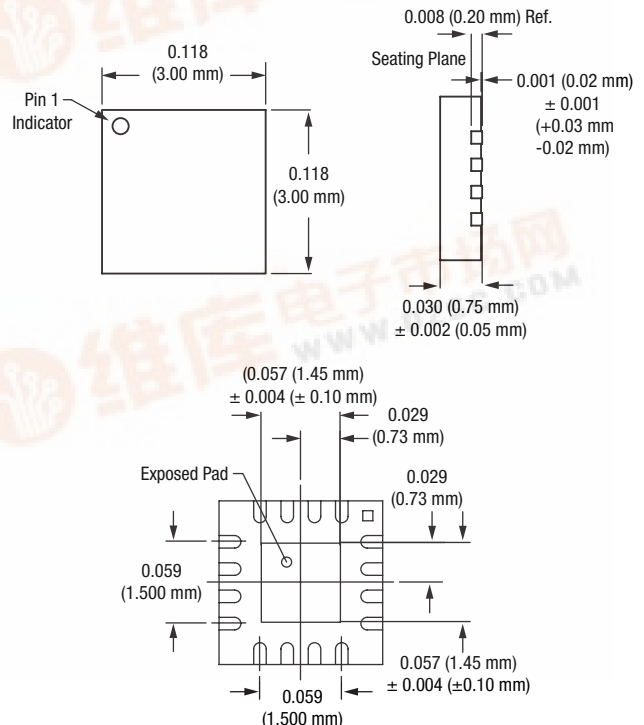

### Pin Assignments

Pin	Symbol	Description
1, 3, 8, 14	GND	Equipotential point. Connect to the printed circuit board common via the lowest possible impedance.
2	RF IN	RF input to the amplifier
4	V <sub>CC1</sub>	DC power supply voltage input to the first amplifier stage
5	V <sub>APC1</sub>	Power control voltage input to the first and second amplifier stages
6	V <sub>APC2</sub>	Power control voltage input to the final amplifier stage
9, 10, 11, 12	RF OUT/V <sub>CC3</sub>	RF output port and DC power supply voltage input to the final amplifier stage. These pins should be connected together directly at the pins for DC current sharing.
13	Z <sub>FC</sub>	(Optional) Harmonic trap. Connect a series resonant circuit at the second harmonic of the RF input signal to reduce second harmonic power at the RF output.
15, 16	V <sub>CC1</sub>	DC power supply voltage input to the second amplifier stage. These pins should be connected together directly at the pins for DC current sharing.
Exposed Pad		Connect to the printed circuit board common via the lowest possible electrical and thermal impedance.

### Absolute Maximum Ratings

Characteristic	Value
Supply voltage (V <sub>CC</sub> & V <sub>REF</sub> )	6.0 V
Power control voltage (V <sub>APC1</sub> & V <sub>APC2</sub> )	4.2 V
RF input power	15 dBm
Operating temperature	-40 °C to +85 °C
Storage temperature	-65 °C to +85 °C

Performance is guaranteed only under the conditions listed in the specifications table and is not guaranteed under the full range(s) described by the Absolute Maximum specifications. Exceeding any of the absolute maximum/minimum specifications may result in permanent damage to the device and will void the warranty.

**CAUTION:** Although this device is designed to be as robust as possible, ESD (Electrostatic Discharge) can damage this device. This device must be protected at all times from ESD. Static charges may easily produce potentials of several kilovolts on the human body or equipment, which can discharge without detection. Industry-standard ESD precautions must be employed at all times.

### General DC Electrical Specifications

Parameter	Symbol	Condition	Min.	Typ.	Max.	Unit
Supply voltage	V <sub>CC</sub>		2.7	3.2	4.2	V
Power control voltage	V <sub>APC</sub>		0.1	2.6	2.8	V
Power control current	I <sub>VAPC</sub>				5	mA
Leakage current	S <sub>21</sub>	P <sub>IN</sub> < -30 dBm, V <sub>APC1, 2</sub> = 0.1 V			10	µA

### General RF Transmit Electrical Specifications

Conditions: V<sub>CC</sub> = 3.2 V, V<sub>REF</sub> = 3.2 V, V<sub>APC</sub> = 2.6 V, T<sub>A</sub> = 25 °C

Parameter	Symbol	Condition	Min.	Typ.	Max.	Unit
Frequency range	F		900		928	MHz
Gain	S <sub>21</sub>	Small signal		31.6		dB
Gain variation over frequency	ΔS <sub>21</sub>	Small signal		0.26		dB
Input return loss	S <sub>11</sub>	Small signal		-14.7		dB
Output return loss	S <sub>22</sub>	Small signal		-5.7		dB
Quiescent current	I <sub>CQ</sub>	(No RF signal)		0.16		A
Output P <sub>1</sub> dB	P <sub>1</sub> dB	CW		33.1		dBm
Current consumption	I <sub>CC</sub>	Output P <sub>1</sub> dB		1.3		A
Power added efficiency	PAE	Output P <sub>1</sub> dB		50%		%
Second harmonic	F <sub>2</sub>	Output P1dB		-55		dBc
Third harmonic	F <sub>3</sub>	Output P1dB		-66		dBc
Ruggedness		Output VSWR = 10:1, All phase angles, V <sub>CC</sub> = 4.2 V, P <sub>IN</sub> = 10 dBm, V <sub>APC</sub> = 2.6 V	No module damage or permanent performance degradation			
Stability		Output VSWR = 10:1, All phase angles, V <sub>CC</sub> = 4.2 V, P <sub>IN</sub> = 10 dBm, V <sub>APC</sub> = 2.6 V		-36		dBm

**Typical Performance Data**

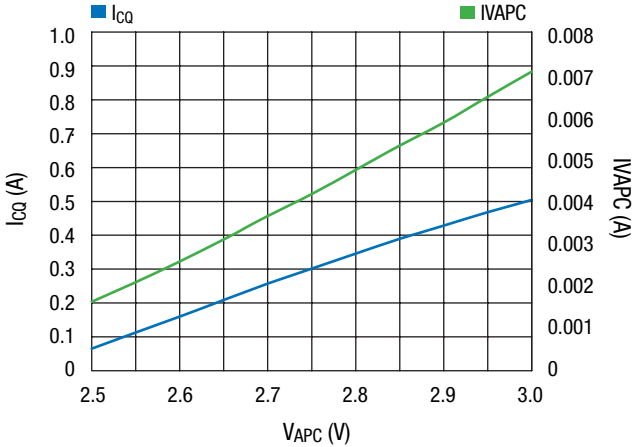

**I<sub>CQ</sub> and I<sub>VAPC</sub> vs. V<sub>APC</sub>**  
 Conditions: V<sub>CC</sub> = 3.2 V, V<sub>REF</sub> = 3.2 V, T<sub>A</sub> = 25 °C

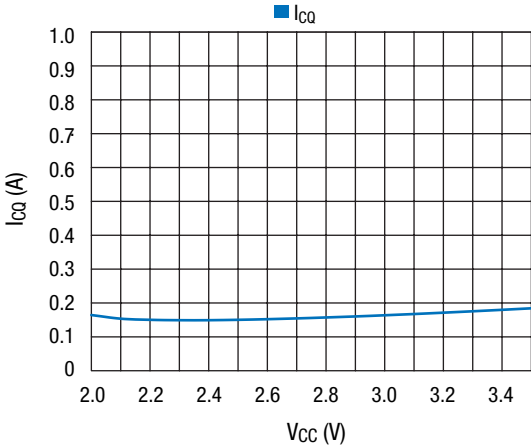

**I<sub>CQ</sub> vs. V<sub>CC</sub>**  
 Conditions: V<sub>APC</sub> = 3.2 V, V<sub>REF</sub> = 3.2 V, T<sub>A</sub> = 25 °C

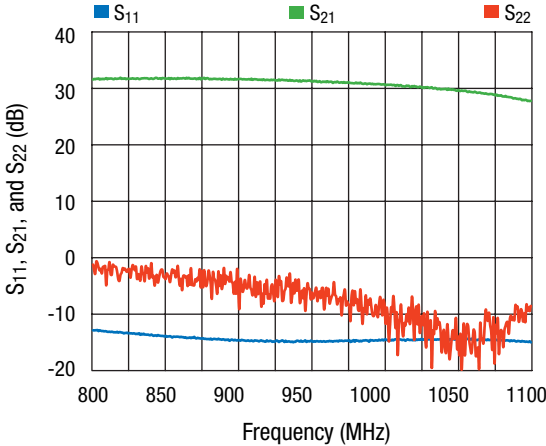

**Small Signal Parameters**  
 Conditions: V<sub>CC</sub> = 3.2 V, V<sub>REF</sub> = 3.2 V,  
 V<sub>APC</sub> = 2.6 V, T<sub>A</sub> = 25 °C

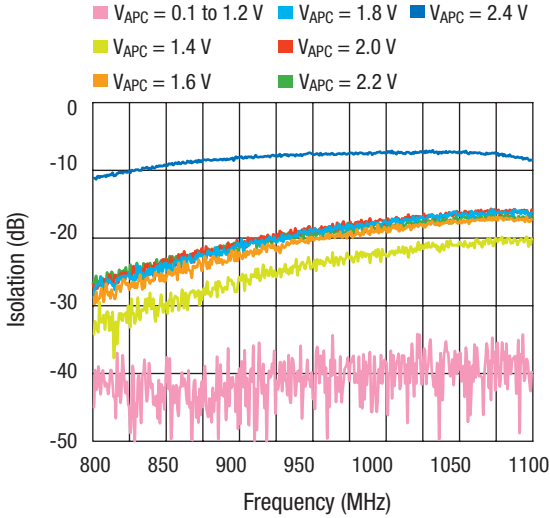

**Forward Isolation**  
 Conditions: V<sub>CC</sub> = 3.2 V, V<sub>REF</sub> = 3.2 V, T<sub>A</sub> = 25 °C

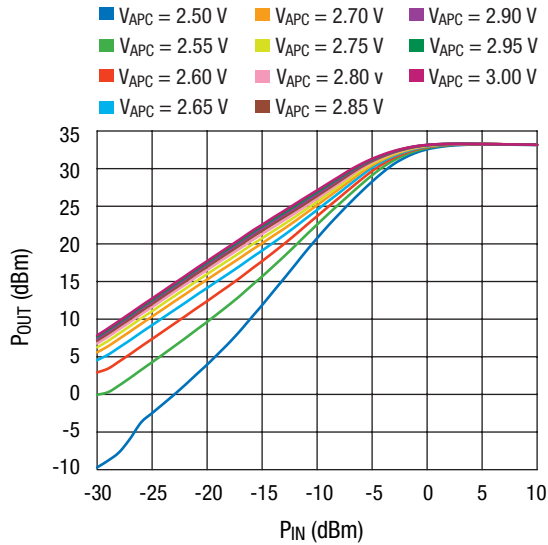

**P<sub>IN</sub> vs. P<sub>OUT</sub> at V<sub>APC</sub>**  
 Conditions: CW, V<sub>CC</sub> = 3.2 V, V<sub>REF</sub> = 3.2 V,  
 F<sub>C</sub> = 915 MHz, T<sub>A</sub> = 25 °C

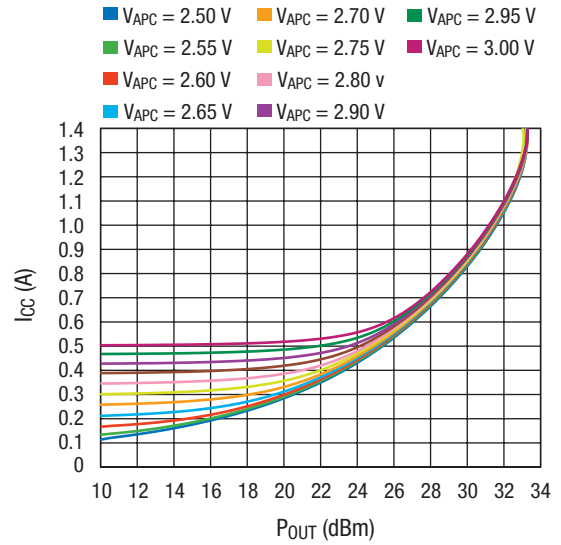

**P<sub>OUT</sub> vs. I<sub>CC</sub> at V<sub>APC</sub>**  
 Conditions: CW, V<sub>CC</sub> = 3.2 V, V<sub>REF</sub> = 3.2 V,  
 F<sub>C</sub> = 915 MHz, T<sub>A</sub> = 25 °C

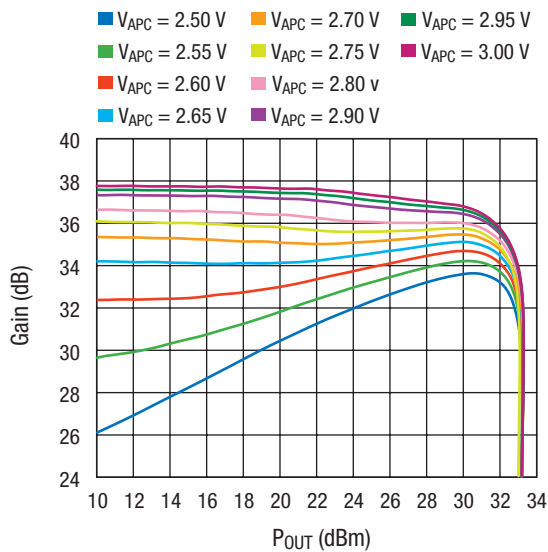

**P<sub>OUT</sub> vs. Gain at V<sub>APC</sub>**  
 Conditions: CW, V<sub>CC</sub> = 3.2 V, V<sub>REF</sub> = 3.2 V,  
 F<sub>C</sub> = 915 MHz, T<sub>A</sub> = 25 °C

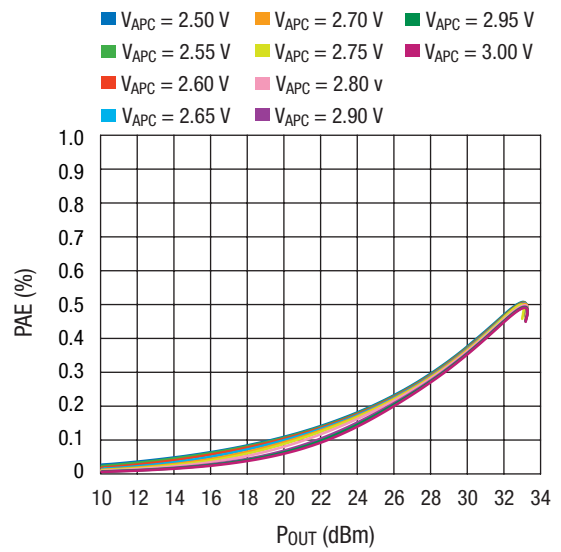

**P<sub>OUT</sub> vs. PAE at V<sub>APC</sub>**  
 Conditions: CW, V<sub>CC</sub> = 3.2 V, V<sub>REF</sub> = 3.2 V,  
 F<sub>C</sub> = 915 MHz, T<sub>A</sub> = 25 °C

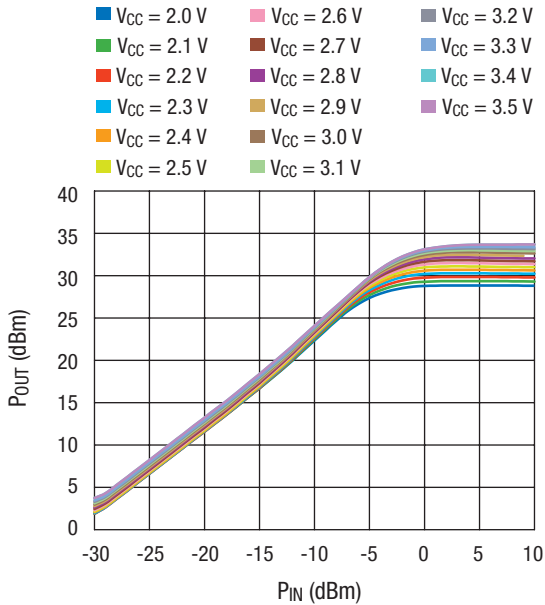

**P<sub>IN</sub> vs. P<sub>OUT</sub> at V<sub>CC</sub>**  
 Conditions: CW, V<sub>APC</sub> = 2.6 V, V<sub>REF</sub> = 3.2 V,  
 F<sub>C</sub> = 915 MHz, T<sub>A</sub> = 25 °C

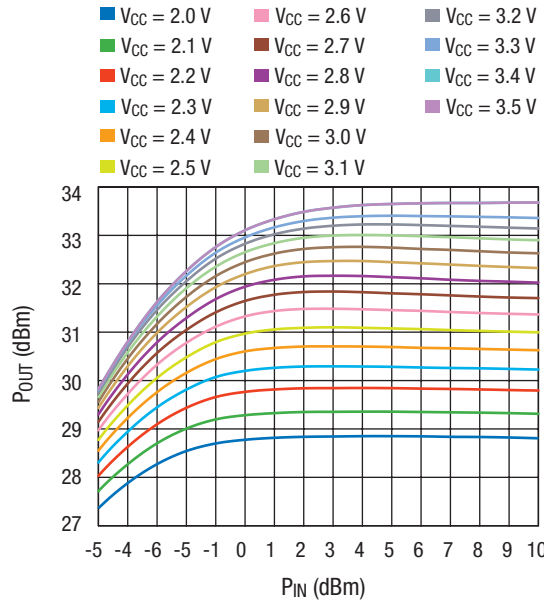

**P<sub>IN</sub> vs. P<sub>OUT</sub> at V<sub>CC</sub>**  
 Conditions: CW, V<sub>APC</sub> = 2.6 V, V<sub>REF</sub> = 3.2 V,  
 F<sub>C</sub> = 915 MHz, T<sub>A</sub> = 25 °C

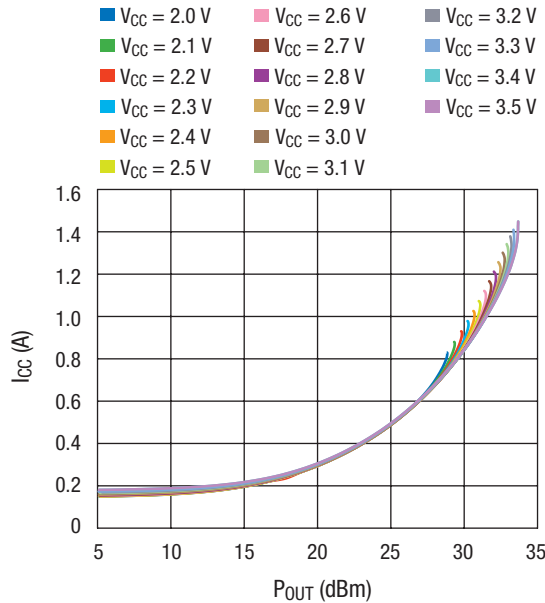

**P<sub>OUT</sub> vs. I<sub>CC</sub> at V<sub>CC</sub>**  
 Conditions: CW, V<sub>APC</sub> = 2.6 V, V<sub>REF</sub> = V<sub>CC</sub>,  
 F<sub>C</sub> = 915 MHz, T<sub>A</sub> = 25 °C

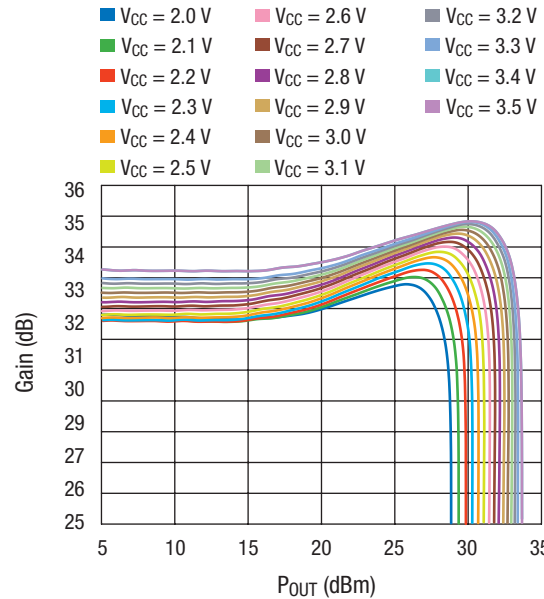

**P<sub>OUT</sub> vs. Gain at V<sub>CC</sub>**  
 Conditions: CW, V<sub>APC</sub> = 2.6 V, V<sub>REF</sub> = V<sub>CC</sub>,  
 F<sub>C</sub> = 915 MHz, T<sub>A</sub> = 25 °C

PRELIMINARY DATA SHEET • AP147-320

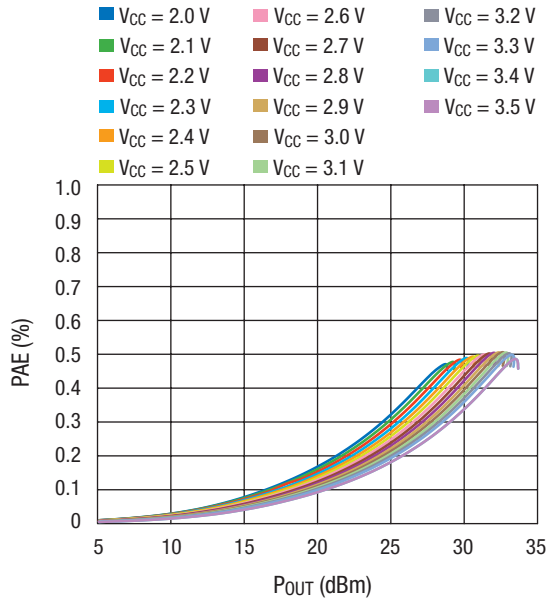

**P<sub>OUT</sub> vs. PAE at V<sub>CC</sub>**  
 Conditions: CW, V<sub>APC</sub> = 2.6 V, V<sub>REF</sub> = V<sub>CC</sub>,  
 F<sub>C</sub> = 915 MHz, T<sub>A</sub> = 25 °C

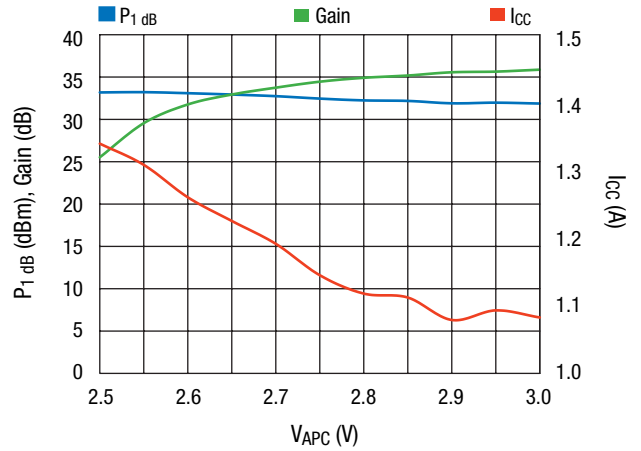

**P<sub>1</sub> dB, Gain, and I<sub>CC</sub> vs. V<sub>APC</sub>**  
 Conditions: CW, V<sub>CC</sub> = 3.2 V, V<sub>REF</sub> = V<sub>CC</sub>,  
 F<sub>C</sub> = 915 MHz, T<sub>A</sub> = 25 °C

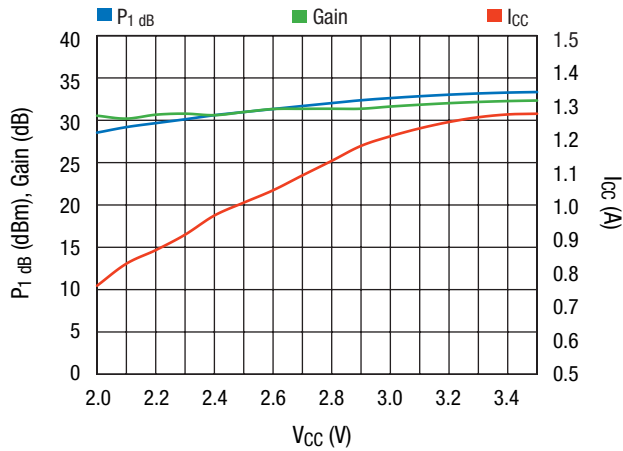

**P<sub>1</sub> dB, Gain, and I<sub>CC</sub> vs. V<sub>CC</sub>**  
 Conditions: CW, V<sub>APC</sub> = 2.6 V, V<sub>REF</sub> = V<sub>CC</sub>,  
 F<sub>C</sub> = 915 MHz, T<sub>A</sub> = 25 °C

**Bill of Material for Evaluation Board**

Part #	ID	Size	Value	Units	Manufacturer	Product Number
1	L <sub>1</sub>	0402	1.8	nH	Johanson	L-07C1N8ST
2	R <sub>1</sub>	0402	180	Ω	Panasonic*	ERJ2GEJ181X
3	C <sub>1</sub>	0402	100	pF	Murata	GRM1555C1H101JD83E
4	C <sub>2</sub>	0402	18	pF	Murata	GRM1555C1H180JZ35E
5	C <sub>3</sub>	0402	DO NOT PLACE			
6	C <sub>4</sub>	0402	DO NOT PLACE			
7	C <sub>5</sub>	0402	DO NOT PLACE			
8	C <sub>6</sub>	0402	DO NOT PLACE			
9	C <sub>7</sub>	1206	10	μF	AVX	TAJA106M006R
10	C <sub>8</sub>	0402	100	pF	Murata	GRM1555C1H101JD83E
11	C <sub>9</sub>	0402	1	nF	Murata	GRM155R71H102KA01*
12	C <sub>10</sub>	0402	10	nF	Murata	GRM155R71E103KA01*
13	C <sub>11</sub>	0402	100	nF	Murata	GRM155R71A104KA01*
14	C <sub>12</sub>	0402	100	pF	Murata	GRM1555C1H101JD83E
15	C <sub>13</sub>	0402	100	pF	Murata	GRM1555C1H101JD83E
16	C <sub>14</sub>	0402	DO NOT PLACE			
17	C <sub>15</sub>	0402	DO NOT PLACE			
18	C <sub>16</sub>	0402	DO NOT PLACE			
19	C <sub>17</sub>	0402	68	pF	Murata	GRM1555C1H680JD83*
20	C <sub>18</sub>	1206	10	μF	AVX	TAJA106M006R
21	C <sub>19</sub>	0402	100	nF	Murata	GRM155R71A104KA01*
22	C <sub>20</sub>	0402	10	nF	Murata	GRM155R71E103KA01*
23	C <sub>21</sub>	0402	1	nF	Murata	GRM155R71H102KA01*
24	C <sub>22</sub>	0402	100	pF	Murata	GRM1555C1H101JD83E
25	C <sub>23</sub>	0402	100	pF	Murata	GRM1555C1H101JD83E
26	C <sub>24</sub>	0402	10	nF	Murata	GRM155R71E103KA01*
27	C <sub>25</sub>	1206	10	μF	AVX	TAJA106M006R
28	C <sub>26</sub>	0402	100	nF	Murata	GRM155R71A104KA01*
29	C <sub>27</sub>	0402	10	nF	Murata	GRM155R71E103KA01*
30	C <sub>28</sub>	0402	1	nF	Murata	GRM155R71H102KA01*
31	C <sub>29</sub>	0402	100	pF	Murata	GRM1555C1H101JD83E
32	C <sub>30</sub>	0402	15	pF (Hi-Q)	Murata	GJM1555C1H150JB01E
33	C <sub>31</sub>	0402	100	pF	Murata	GRM1555C1H101JD83E
34	C <sub>32</sub>	0402	4.7	pF (Hi-Q)	Murata	GJM1555C1H4R7CB01E
35	SMA Connector, 50 Ω (X2)				AEP	9114-9113-000
36	PCB					

\* Panasonic is Skyworks preferred vendor, however any suitable equivalent will do.

### Application Circuit

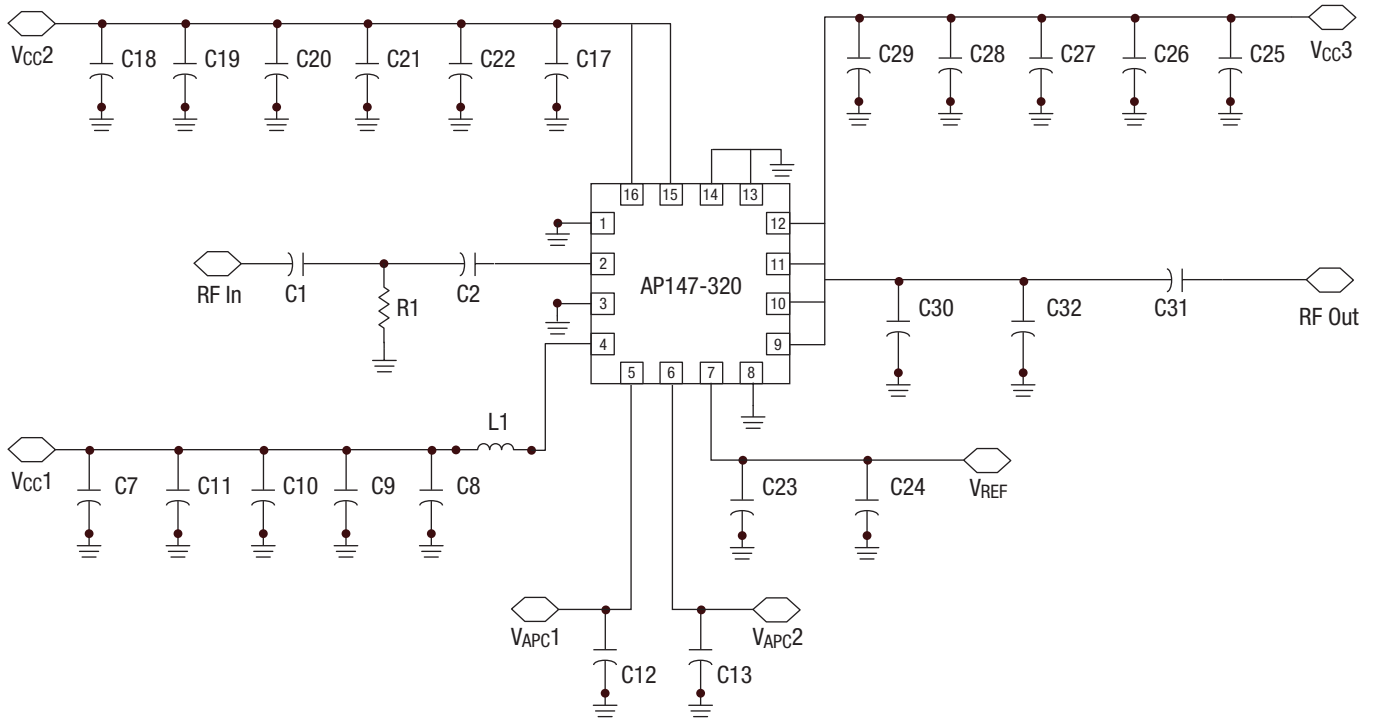

### Component Placement Diagram

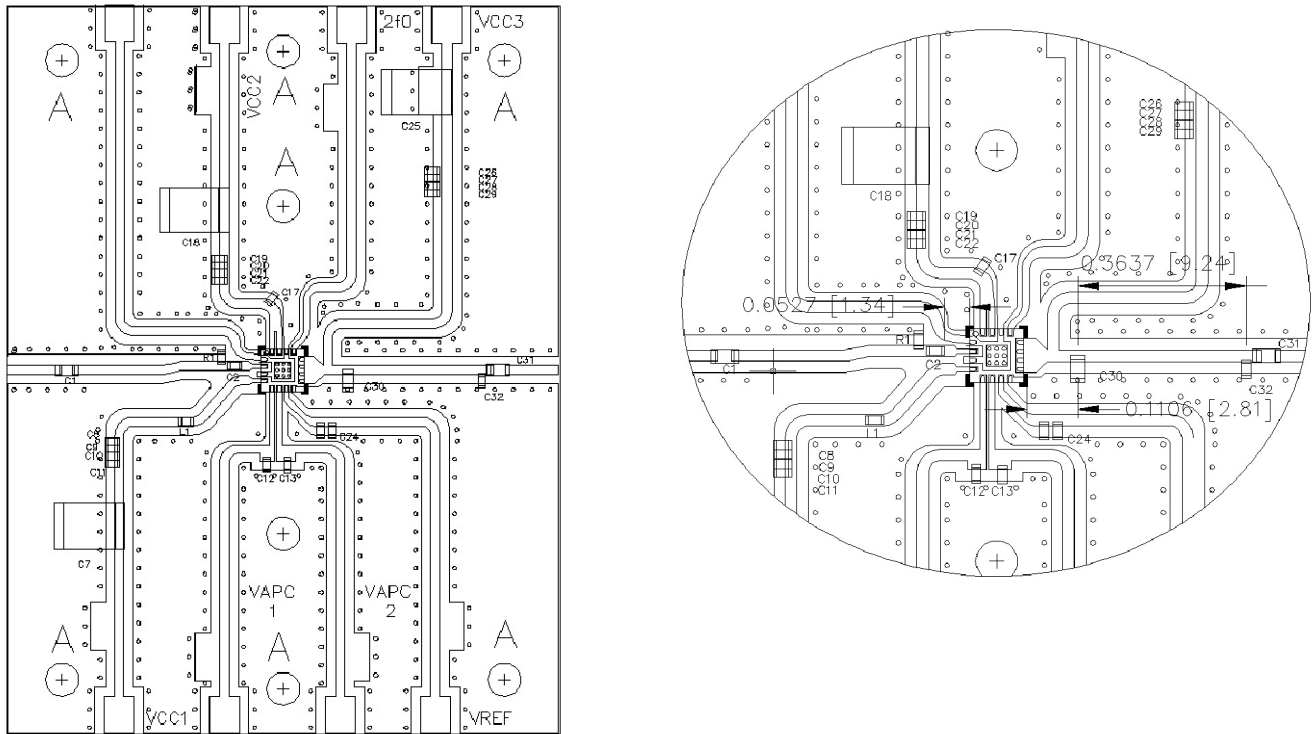

Coplanar spacing: 0.026 inches.  
Transmission line width: 0.025 inches.



### Application Circuit Notes

RF Input, Pin 2, uses a 100 pF (C<sub>1</sub>) DC blocking capacitor, a 180 Ω (R<sub>1</sub>) resistor, and a 18 pF (C<sub>2</sub>) tuning capacitor. The length of the line between the 18 pF capacitor and the amplifier is important to the input VSWR of the device. This distance is indicated below.

V<sub>CC1</sub>, Pin 4, is the collector bias for stage 1. Capacitors of 10 uF (C<sub>7</sub>), 100 pF (C<sub>8</sub>), 1.0 nF (C<sub>9</sub>), 10 nF (C<sub>10</sub>), 100 nF (C<sub>11</sub>), and an inductor of 1.8 nH (L<sub>1</sub>) are used for cleaning up the power supply input signal and RF bypassing.

V<sub>CC2</sub>, Pin 15, is the collector bias for stage 2. Tuning is accomplished, in conjunction with pin 16, with a 68 pF (C<sub>17</sub>), 1.0 nF (C<sub>21</sub>), and a 100 pF (C<sub>22</sub>) capacitor on the collector bias line. Capacitors of 10 μF (C<sub>18</sub>), 100 pF (C<sub>19</sub>), and 10 nF (C<sub>20</sub>) are used to clean up the power supply input signal.

V<sub>CC2</sub>, Pin 16, is the collector bias for stage 2. Tuning is accomplished, in conjunction with pin 15, with a 68 pF (C<sub>17</sub>), 1.0 nF (C<sub>21</sub>), and a 100 pF (C<sub>22</sub>) capacitor on the collector bias line. Capacitors of 10 μF (C<sub>18</sub>), 100 pF (C<sub>19</sub>), and 10 nF (C<sub>20</sub>) are used to clean up the power supply input signal.

RF OUT/V<sub>CC3</sub>, Pins (9–12), Tuning is accomplished with a 15 pF (C<sub>30</sub>) high-Q capacitor and a 7.0 pF (C<sub>32</sub>) high-Q capacitor on the RF output line. A length of transmission line and a bank of bypassing capacitors of 10 uF (C<sub>25</sub>), 100 nF (C<sub>26</sub>), 10 nF (C<sub>27</sub>), 1.0 nF (C<sub>28</sub>), and 100 pF (C<sub>29</sub>) are required on the drain bias line for tuning and bias injection. A 100 pF (C<sub>31</sub>) DC blocking capacitor is needed on the output line.

VAPC1, Pin 5, is the power control voltage for stages 1 and 2. A 100 pF (C<sub>13</sub>) capacitor is required for biasing. Pin 5 and Pin 6 can be combined right at the amplifier by a jumper or a substrate connection between the two pads. In this configuration, a single 100 pF capacitor could be used for biasing.

VAPC6, Pin 6, is the power control voltage for stages 1 and 2. A 100 pF (C<sub>12</sub>) capacitor is required for biasing. Pin 6 and pin 5 can be combined right at the amplifier by a jumper or a substrate connection between the two pads. In this configuration, a single 100 pF capacitor could be used for biasing.

V<sub>REF</sub>, Pin 7, is the control voltage for the bias control circuit. A combination of a 100 pF (C<sub>23</sub>) and a 10 nF (C<sub>24</sub>) capacitor is required for bypassing.

### Package Footprint

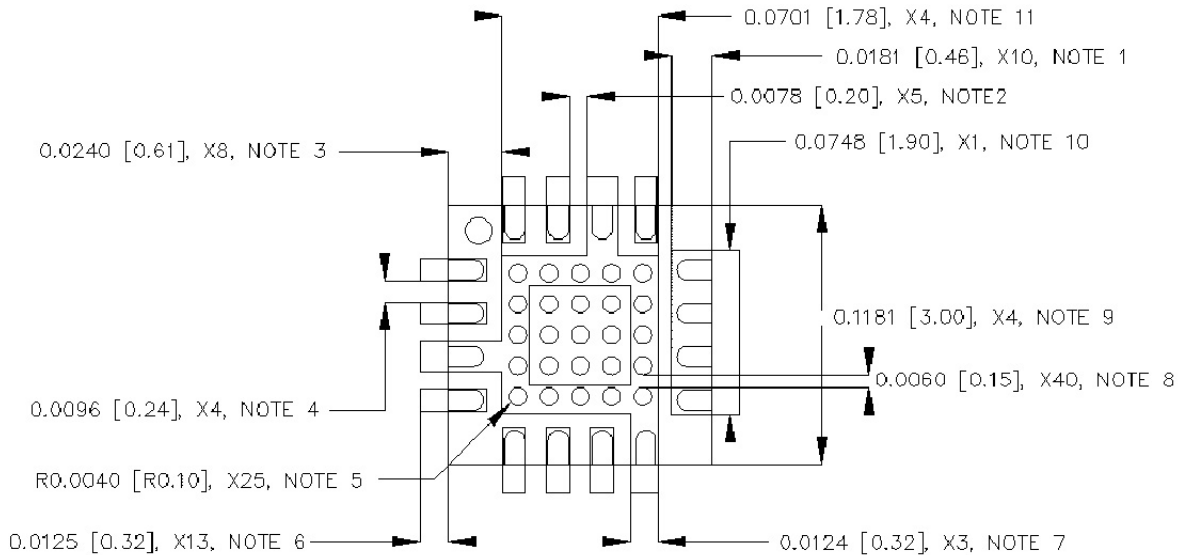

- NOTE: All units in inches [mm].
- NOTE 1: Length of all non-grounded lands underneath the package.
  - NOTE 2: Width between grounded lands and non-grounded lands.
  - NOTE 3: Length of from ground pad to edge of package.
  - NOTE 4: Width between non-grounded lands.
  - NOTE 5: Radius of the vias.
  - NOTE 6: Length of all lands from the edge of the package.
  - NOTE 7: Width of the ground lands.
  - NOTE 8: Distance between all vias.
  - NOTE 9: X and Y dimension of the package.
  - NOTE 10: Width of the land for RFOUT.
  - NOTE 11: Width of the land for the ground pad.

### Evaluation Board Stack-Up

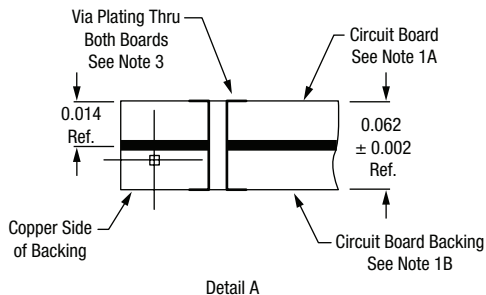

### Application Board Bias Procedure

Step 1. Connect DC ground to the pad located in the top right-hand corner of the board as indicated below.

Step 2. Connect Stage 1 collector bias voltage,  $V_{CC1}$ , to the pad at the bottom left side of the board as indicated below.  $V_{CC1} = 3.2\text{ V}$

Step 3. Connect Stage 2 collector bias voltage,  $V_{CC2}$ , to the second pad in from the top left side of the board as indicated below.  $V_{CC2} = 3.2\text{ V}$

Step 4. Connect Stage 3 collector bias voltage,  $V_{CC3}$ , to the first pad at the top right side of the board as indicated below.  $V_{CC3} = 3.2\text{ V}$

Step 5. Connect the bias control voltage,  $V_{REF}$  to the pad at the bottom right of the board as indicated below.  $V_{REF}$  should be tied to the same line as  $V_{CC1}$ ,  $V_{CC2}$ , and  $V_{CC3}$  to obtain a single voltage supply.

**NOTE:** It is important that the  $V_{CC1}$ ,  $V_{CC2}$ ,  $V_{CC3}$ , and  $V_{REF}$  voltage source be adjusted such that 3.2 V is measured at the board. The high drain currents will drop the drain voltage significantly if long leads are used. Adjust the bias voltage to compensate.

### Recommended Solder Reflow Profiles

Refer to the [“Recommended Solder Reflow Profile”](#) Application Note.

### Tape and Reel Information

Refer to the [“Discrete Devices and IC Switch/Attenuators Tape and Reel Package Orientation”](#) Application Note.

Step 6. Connect the power control voltages,  $V_{APC1}$  and  $V_{APC2}$ , the middle two pads on the bottom of the board, as indicated below. This is done to obtain a single control voltage supply.  $V_{APC} = 0\text{ V}$  at this point.

Step 7. Apply RF at RF IN port at -20 dBm to start, then adjust power level to 0 to 5 dBm.

Step 8. The  $V_{APC}$  can be increased to 2.8 V max. or until desired output power level is achieved at RF OUT port.

Step 9. The pads in the upper left-hand corner, first from the left and third from the left, are to be grounded.

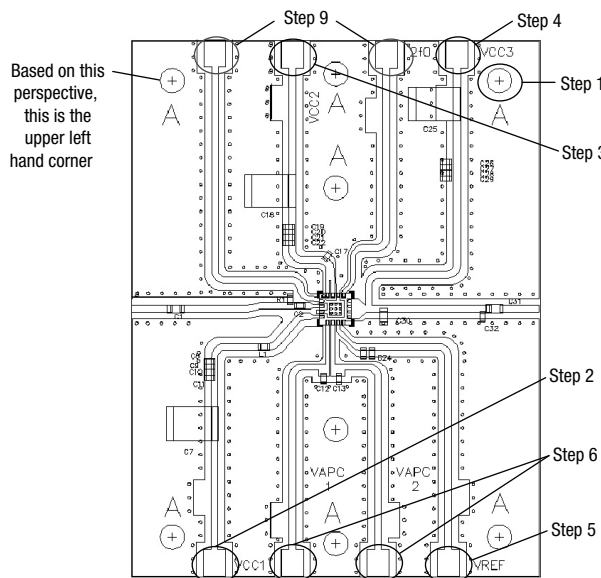

### Branding Specifications

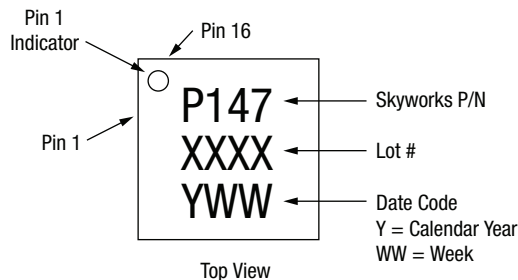

Copyright © 2002, 2003, 2004, 2005, 2006, Skyworks Solutions, Inc. All Rights Reserved.

Information in this document is provided in connection with Skyworks Solutions, Inc. ("Skyworks") products or services. These materials, including the information contained herein, are provided by Skyworks as a service to its customers and may be used for informational purposes only by the customer. Skyworks assumes no responsibility for errors or omissions in these materials or the information contained herein. Skyworks may change its documentation, products, services, specifications or product descriptions at any time, without notice. Skyworks makes no commitment to update the materials or information and shall have no responsibility whatsoever for conflicts, incompatibilities, or other difficulties arising from any future changes.

No license, whether express, implied, by estoppel or otherwise, is granted to any intellectual property rights by this document. Skyworks assumes no liability for any materials, products or information provided hereunder, including the sale, distribution, reproduction or use of Skyworks products, information or materials, except as may be provided in Skyworks Terms and Conditions of Sale.

THE MATERIALS, PRODUCTS AND INFORMATION ARE PROVIDED "AS IS" WITHOUT WARRANTY OF ANY KIND, WHETHER EXPRESS, IMPLIED, STATUTORY, OR OTHERWISE, INCLUDING FITNESS FOR A PARTICULAR PURPOSE OR USE, MERCHANTABILITY, PERFORMANCE, QUALITY OR NON-INFRINGEMENT OF ANY INTELLECTUAL PROPERTY RIGHT; ALL SUCH WARRANTIES ARE HEREBY EXPRESSLY DISCLAIMED. SKYWORKS DOES NOT WARRANT THE ACCURACY OR COMPLETENESS OF THE INFORMATION, TEXT, GRAPHICS OR OTHER ITEMS CONTAINED WITHIN THESE MATERIALS. SKYWORKS SHALL NOT BE LIABLE FOR ANY DAMAGES, INCLUDING BUT NOT LIMITED TO ANY SPECIAL, INDIRECT, INCIDENTAL, STATUTORY, OR CONSEQUENTIAL DAMAGES, INCLUDING WITHOUT LIMITATION, LOST REVENUES OR LOST PROFITS THAT MAY RESULT FROM THE USE OF THE MATERIALS OR INFORMATION, WHETHER OR NOT THE RECIPIENT OF MATERIALS HAS BEEN ADVISED OF THE POSSIBILITY OF SUCH DAMAGE.

Skyworks products are not intended for use in medical, lifesaving or life-sustaining applications, or other equipment in which the failure of the Skyworks products could lead to personal injury, death, physical or environmental damage. Skyworks customers using or selling Skyworks products for use in such applications do so at their own risk and agree to fully indemnify Skyworks for any damages resulting from such improper use or sale.

Customers are responsible for their products and applications using Skyworks products, which may deviate from published specifications as a result of design defects, errors, or operation of products outside of published parameters or design specifications. Customers should include design and operating safeguards to minimize these and other risks. Skyworks assumes no liability for applications assistance, customer product design, or damage to any equipment resulting from the use of Skyworks products outside of stated published specifications or parameters.

Skyworks, the Skyworks symbol, and "Breakthrough Simplicity" are trademarks or registered trademarks of Skyworks Solutions, Inc., in the United States and other countries. Third-party brands and names are for identification purposes only, and are the property of their respective owners. Additional information, including relevant terms and conditions, posted at [www.skyworksinc.com](http://www.skyworksinc.com), are incorporated by reference.