



CONSTANT VOLTAGE AND CONSTANT CURRENT CONTROLLER

AP4313

General Description

The AP4313 is a highly integrated solution for a constant voltage/constant current mode SMPS application.

The AP4313 contains one 1.21V voltage reference with $\pm 1\%$ accuracy, one current sensing circuit and two operational amplifiers. Combining the voltage reference with one operational amplifier makes AP4313 an ideal voltage controller for use in adapters and battery chargers. The other low voltage reference combined with the other operational amplifier makes it an ideal current limiter for output low side current sensing.

The AP4313 is available in SOT-23-6 package.

Features

- Constant Voltage and Constant Current Control
- Precision Internal Voltage Reference
- Few External Components
- Easy Compensation

Applications

- Adapters
- Battery Chargers



Figure 1. Package Type of AP4313





CONSTANT VOLTAGE AND CONSTANT CURRENT CONTROLLER AP4313

Pin Configuration

K Package
(SOT-23-6)

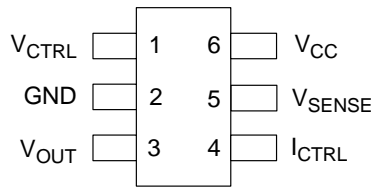

Figure 2. Pin Configuration of AP4313 (Top View)

Pin Description

Pin Number	Pin Name	Function
1	V _{CTRL}	Input pin of the voltage control loop
2	GND	Ground
3	V _{OUT}	Output pin. Sinking current only
4	I _{CTRL}	Input pin of the current control loop
5	V _{SENSE}	Input pin of the current control loop
6	V _{CC}	Power supply



CONSTANT VOLTAGE AND CONSTANT CURRENT CONTROLLER AP4313

Functional Block Diagram

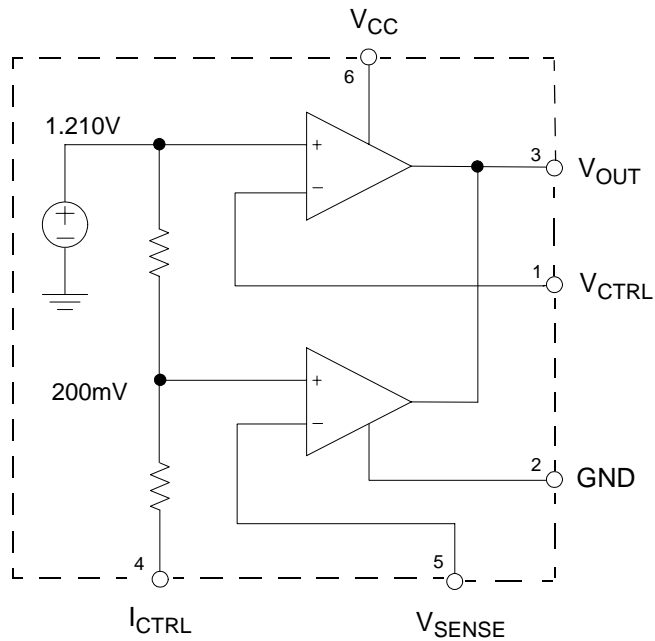
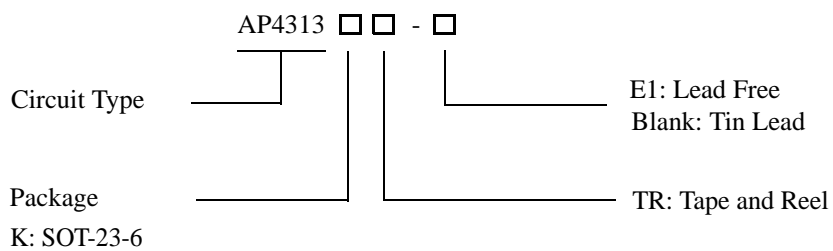

Figure 3. Functional Block Diagram of AP4313

Ordering Information



Package	Temperature Range	Part Number		Marking ID		Packing Type
		Tin Lead	Lead Free	Tin Lead	Lead Free	
SOT-23-6	0 to 70°C	AP4313KTR	AP4313KTR-E1	K6G	E6G	Tape & Reel

BCD Semiconductor's Pb-free products, as designated with "E1" suffix in the part number, are RoHS compliant.

**CONSTANT VOLTAGE AND CONSTANT CURRENT CONTROLLER AP4313****Absolute Maximum Ratings (Note 1)**

Parameter	Symbol	Value	Unit
Power Supply Voltage	V_{CC}	20	V
Input Voltage	V_{IN}	-0.3 to V_{CC}	V
Junction Temperature	T_J	150	°C
Storage Temperature	T_{STG}	-65 to 150	°C
Lead Temperature (Soldering, 5sec)	T_{LEAD}	260	°C
Package Thermal Resistance (Junction to Case)	θ_{JC}	92	°C/W

Note 1: Stresses greater than those listed under "Absolute Maximum Ratings" may cause permanent damage to the device. These are stress ratings only, and functional operation of the device at these or any other conditions beyond those indicated under "Recommended Operating Conditions" is not implied. Exposure to "Absolute Maximum Ratings" for extended periods may affect device reliability.

Recommended Operating Conditions

Parameter	Symbol	Min	Max	Unit
Power Supply Voltage	V_{CC}	2.5	18	V
Operating Temperature Range	T_A	0	70	°C



CONSTANT VOLTAGE AND CONSTANT CURRENT CONTROLLER AP4313

Electrical Characteristics

($V_{CC}=5V$, $T_A=25^{\circ}C$, unless otherwise specified.)

Parameter	Symbol	Conditions	Min	Typ	Max	Unit
TOTAL CURRENT CONSUMPTION						
Total Supply Current Not Including the Output Sinking Current	I_{CC}			0.6	1.2	mA
VOLTAGE CONTROL LOOP						
Transconduction Gain (V_{CTRL}). Sink Current Only	G_{mv}		1	3.5		mA/mV
Voltage Control Loop Reference	V_{REF}		1.198	1.21	1.222	V
Input Bias Current (V_{CTRL})	I_{IBV}			50		nA
CURRENT CONTROL LOOP						
Transconduction Gain (I_{CTRL}).	G_{mi}		1.5	7		mA/mV
Current Control Loop Reference	V_{SENSE}	$I_{OUT}=2.5mA$	196	200	204	mV
Current Out of Pin I_{CTRL} at -200mV	I_{IBI}			25		μA
OUTPUT STAGE						
Low Output Voltage at 10mA Sinking Current	V_{OL}			200		mV
Output Short Circuit Current. Output to V_{CC} . Sink Current Only	I_{OS}			27	50	mA



CONSTANT VOLTAGE AND CONSTANT CURRENT CONTROLLER AP4313

Typical Performance Characteristics

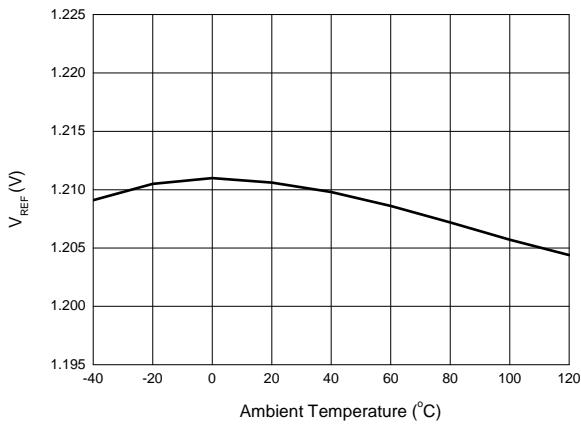

Figure 4. V_{REF} vs. Ambient Temperature

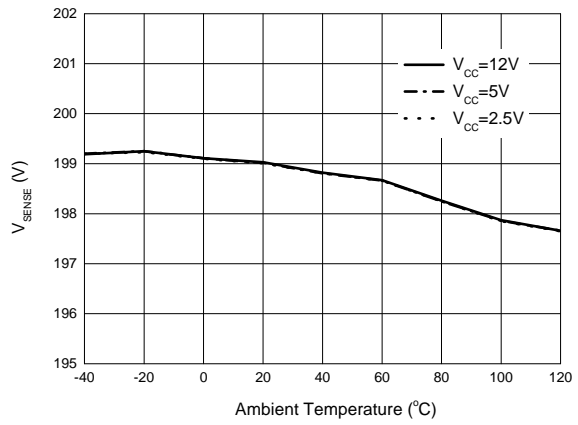

Figure 5. V_{SENSE} vs. Ambient Temperature

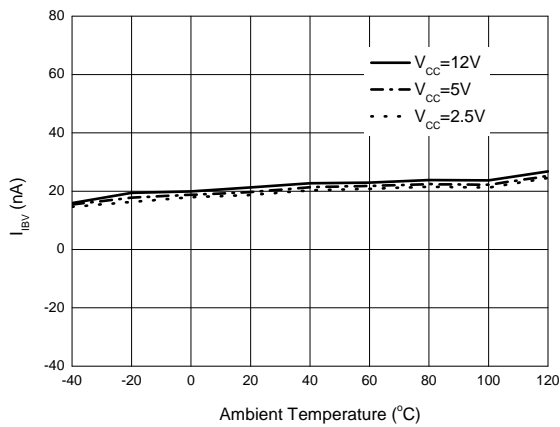

Figure 6. V_{CTRL} Pin Input Bias Current vs. Ambient Temperature

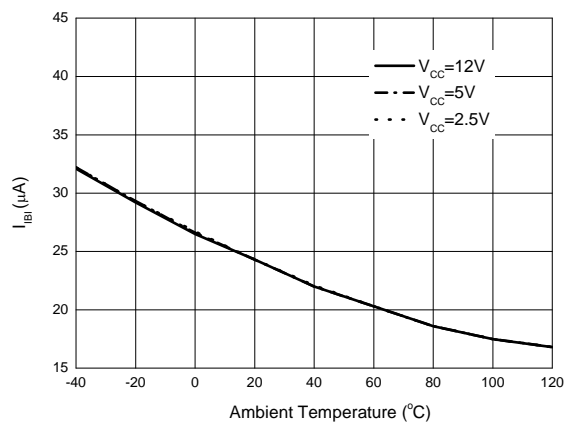

Figure 7. I_{CTRL} Pin Input Bias Current vs. Ambient Temperature



CONSTANT VOLTAGE AND CONSTANT CURRENT CONTROLLER AP4313

Typical Performance Characteristics (Continued)

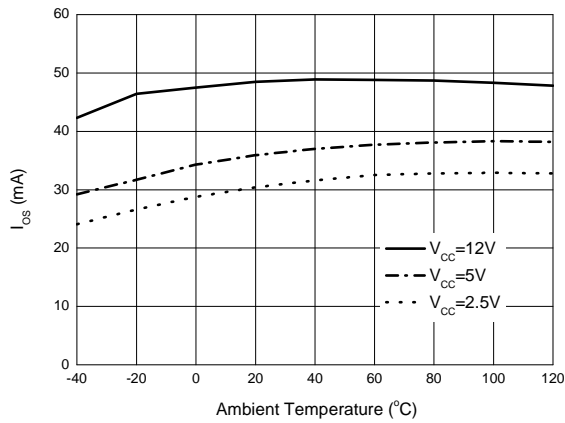

Figure 8. Output Short Circuit Current vs. Ambient Temperature

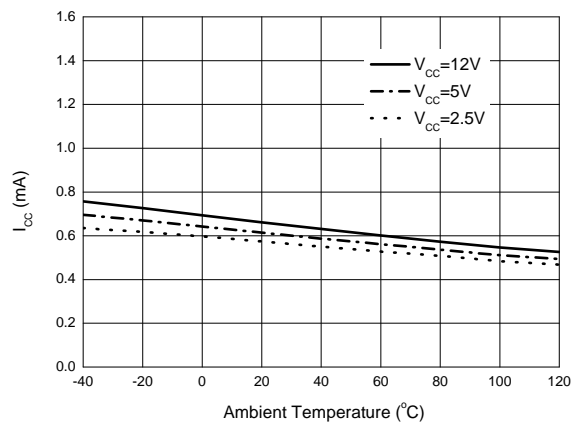

Figure 9. Supply Current vs. Ambient Temperature



CONSTANT VOLTAGE AND CONSTANT CURRENT CONTROLLER AP4313

Typical Application

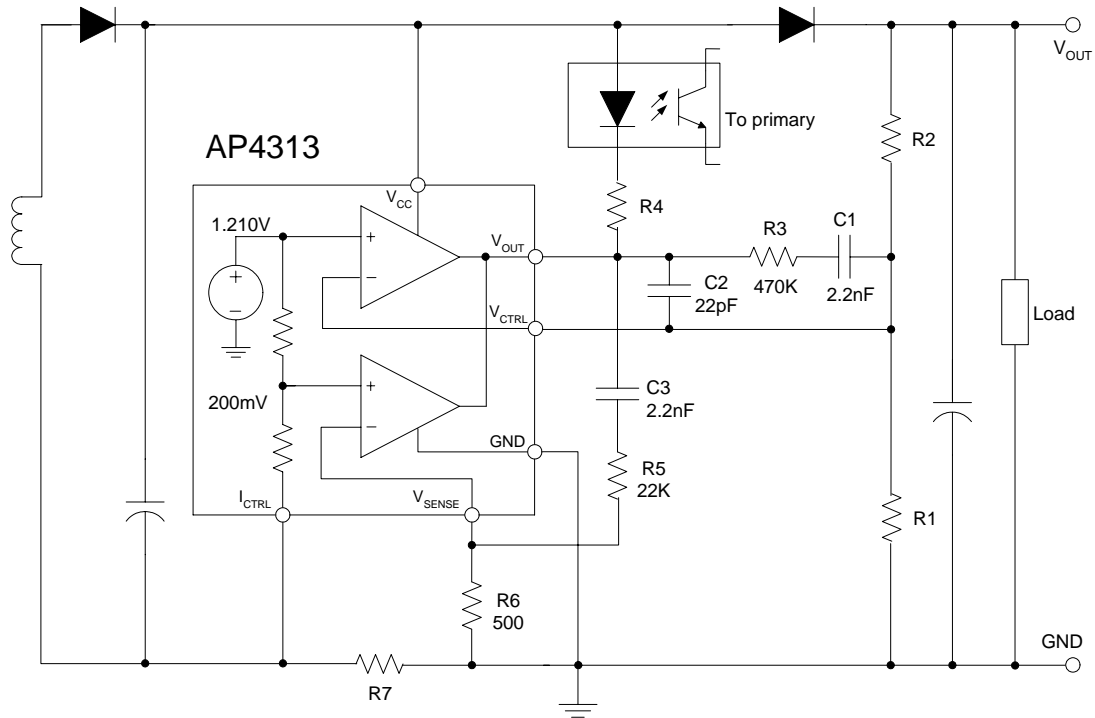

Figure 10. Typical Application of AP4313



CONSTANT VOLTAGE AND CONSTANT CURRENT CONTROLLER AP4313

Mechanical Dimensions

SOT-23-6

Unit: mm(inch)

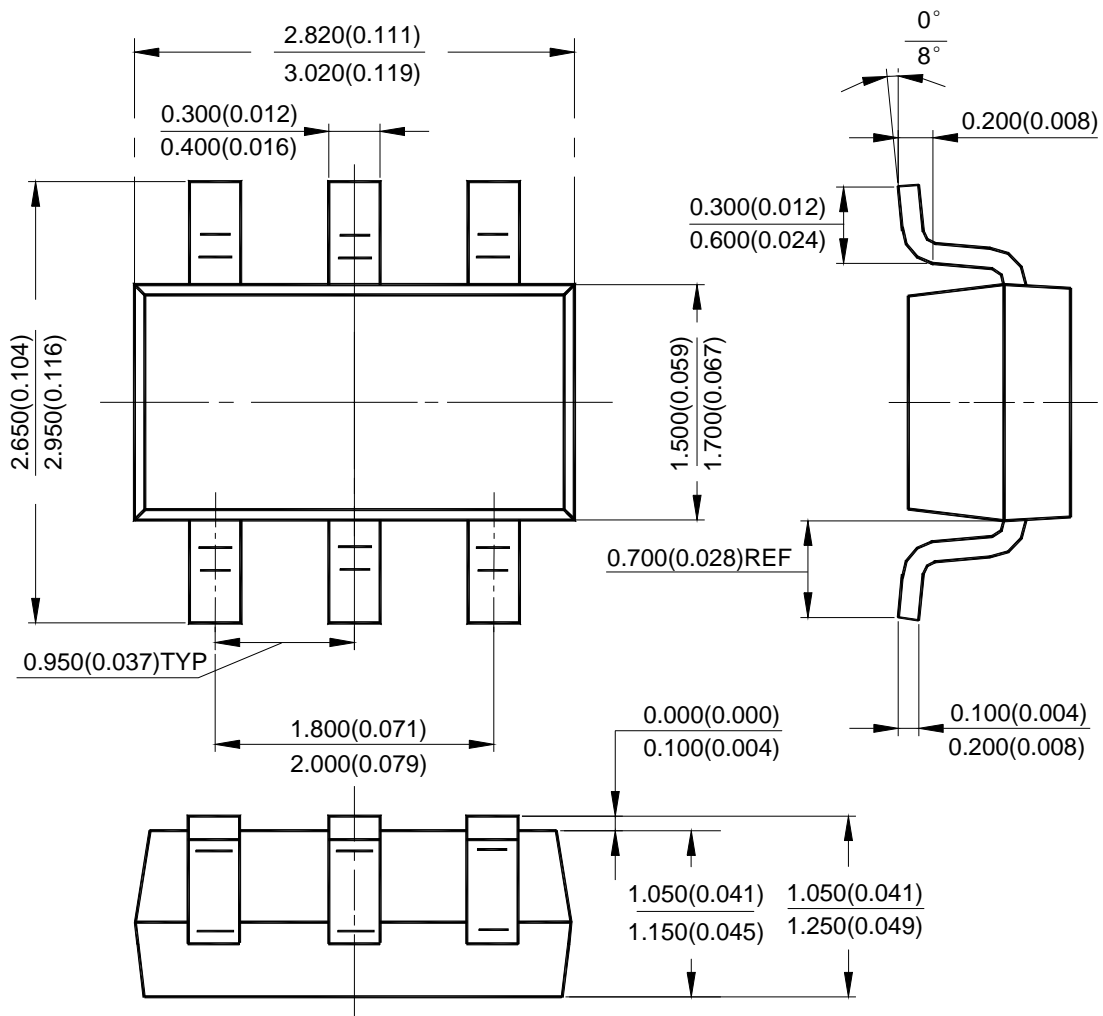



BCD Semiconductor Manufacturing Limited

<http://www.bcdsemi.com>

IMPORTANT NOTICE

BCD Semiconductor Manufacturing Limited reserves the right to make changes without further notice to any products or specifications herein. BCD Semiconductor Manufacturing Limited does not assume any responsibility for use of any its products for any particular purpose, nor does BCD Semiconductor Manufacturing Limited assume any liability arising out of the application or use of any its products or circuits. BCD Semiconductor Manufacturing Limited does not convey any license under its patent rights or other rights nor the rights of others.

MAIN SITE

BCD Semiconductor Manufacturing Limited
- Wafer Fab
Shanghai SIM-BCD Semiconductor Manufacturing Limited
800, Yi Shan Road, Shanghai 200233, China
Tel: +86-21-6485 1491, Fax: +86-21-5450 0008

BCD Semiconductor Manufacturing Limited
- IC Design Group
Advanced Analog Circuits (Shanghai) Corporation
8F, Zone B, 900, Yi Shan Road, Shanghai 200233, China
Tel: +86-21-6495 9539, Fax: +86-21-6485 9673

REGIONAL SALES OFFICE

Shenzhen Office
Shanghai SIM-BCD Semiconductor Manufacturing Co., Ltd. Shenzhen Office
Advanced Analog Circuits (Shanghai) Corporation Shenzhen Office
27B, Tower C, 2070, Middle Shen Nan Road, Shenzhen 518031, China
Tel: +86-755-8368 3987, Fax: +86-755-8368 3166

Taiwan Office
BCD Semiconductor (Taiwan) Company Limited
4F, 298-1, Rui Guang Road, Nei-Hu District, Taipei, Taiwan
Tel: +886-2-2656 2808, Fax: +886-2-2656 2806

USA Office
BCD Semiconductor Corporation
3170 De La Cruz Blvd., Suite 105, Santa Clara, CA 95054-2411, U.S.A
Tel: +1-408-988 6388, Fax: +1-408-988 6386