



AP5004

PWM CONTROL 2.5A STEP-DOWN CONVERTER

Features

- Input Voltage: 10V to 32V
- Adjustable Output Voltage from 0.8V to 6V
- Duty Ratio: 0% to 90% PWM control
- Oscillation Frequency: 300KHz typical
- Short Circuit Protect Frequency: 50 KHz
- 2uA Maximum Standby Current
- Current Limit, Enable Function
- Thermal Shutdown Function
- Built-in Internal SW N-channel MOS
- SOP-8L: Available in "Green" Molding Compound (No Br, Sb)
- Lead Free Finish/RoHS Compliant (Note 1)

General Description

AP5004 consists of step-down switching regulator with PWM control. These devices include a reference voltage source, oscillation circuit, error amplifier, internal NMOS. AP5004 provides low-ripple power, high efficiency and excellent transient characteristics. The PWM control circuit is able to vary the duty ratio linearly from 0 up to 90%. An enable function, an over current protect function and a short circuit protect function are built inside, and when OCP or SCP happens, the operation frequency will be reduced from 300 KHz to 50 KHz. Also, an internal compensation block is built to minimize external component count. With built-in power NMOS, a step-down switching regulator is easy to be built by adding a coil, capacitors and a diode. The high efficiency, low standby current, high input voltage (32V) and output current (2.5A) combining with small SOP-8L package give AP5004 unprecedented advantage in high power system applications.

Applications

- Microprocessor Core Supply
- Networking Power Supply
- LCD MNT, TV Power Supply
- Telecom Power Supply

Ordering Information

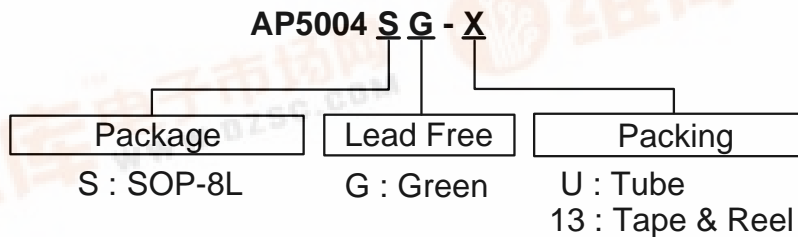

Device	Package Code	Packaging (Note 2)	Tube		13" Tape and Reel	
			Quantity	Part Number Suffix	Quantity	Part Number Suffix
AP5004SG-U	S	SOP-8L	100	-U	NA	NA
AP5004SG-13	S	SOP-8L	NA	NA	2500/Tape & Reel	-13

Notes: 1. EU Directive 2002/95/EC (RoHS). All applicable RoHS exemptions applied, see *EU Directive 2002/95/EC Annex Notes*.
 2. Pad layout as shown on Diodes Inc. suggested pad layout document AP02001, which can be found on our website at <http://www.diodes.com/datasheets/ap02001.pdf>.



Pin Assignments

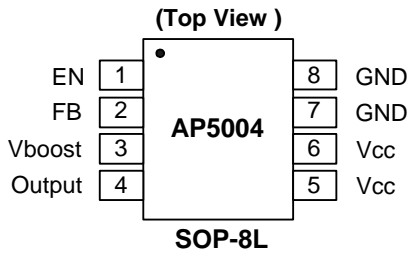

Pin Descriptions

Pin Name	Pin #	Description
EN	1	H: Normal operation L: Step-down operation stopped
FB	2	Feedback pin
V _{boost}	3	High-side gate driver boost pin
Output	4	Switch output pin
V _{CC}	5, 6	Signal V _{CC}
GND	7, 8	GND pin

Block Diagram

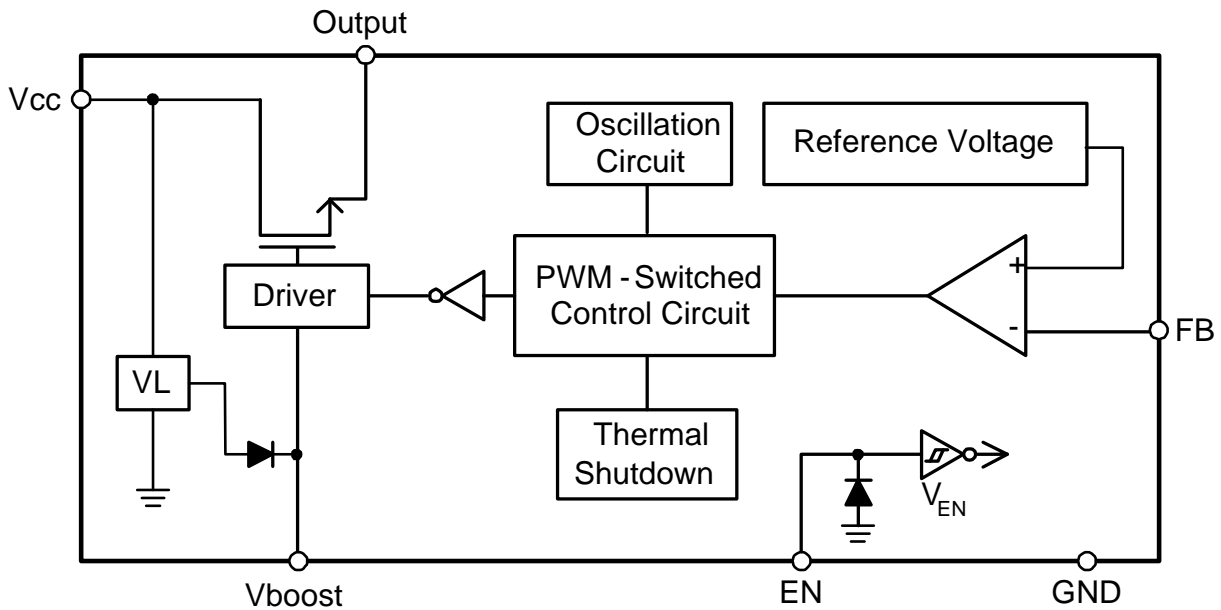

Absolute Maximum Ratings

Symbol	Parameter	Rating	Unit
ESD HBM	Human Body Model ESD Protection	1.8	KV
ESD MM	Machine Model ESD Protection	550	V
V_{CC}	V_{CC} Pin Voltage	$V_{SS} - 0.3$ to $V_{SS} + 35$	V
V_{FB}	V_{OUT} Pin Voltage	$V_{SS} - 0.3$ to V_{CC}	V
V_{EN}	EN Pin Voltage	$V_{SS} - 0.3$ to $V_{CC} + 0.3$	V
V_{boost}	V_{boost} Pin Voltage	$V_{OUTPUT} + 7V$	V
V_{OUTPUT}	Switch Pin Voltage	$V_{SS} - 0.3$ to $V_{CC} + 0.3$	V
T_J	Operating Junction Temperature Range	-10 to +125	°C
T_{ST}	Storage Temperature Range	-40 to +150	°C

Caution: The absolute maximum ratings are rated values exceeding which the product could suffer physical damage. These values must therefore not be exceeded under any conditions.

Recommended Operating Conditions

Symbol	Parameter	Min	Max	Unit
V_{IN}	Input Voltage	10	32	V
I_{OUT}	Output Current	0	2.5	A
T_A	Operating Ambient Temperature	-10	85	°C

Electrical Characteristics (V_{IN} = 12V, T_A = 25°C, unless otherwise specified)

Symbol	Parameter	Conditions	Min	Typ.	Max	Unit
V _{FB}	Feedback Voltage		0.780	0.8	0.820	V
V _{IN}	Input Voltage		10	-	32	V
I _{STBY}	Standby Current	V _{EN} = 0V	-	2	-	μA
ΔV _{OUT} /V _{OUT}	Line Regulation	V _{IN} = 10V~32V	-	±1.0	±1.5	%/V
ΔV _{OUT} /V _{OUT}	Load Regulation	I _{OUT} = 0.1 to 2.5A	-	1	1.5	%
f _{OSC}	Oscillation Frequency	Measure waveform at SW pin	240	300	360	KHz
f _{OSC1}	Frequency of Current Limit or Short Circuit Protect	Measure waveform at SW pin	-	50	-	KHz
DC	Maximum Duty Cycle	V _{FB} = 0.5V	-	90	-	%
	Minimum Duty Cycle	V _{FB} = 1.0V	-	0	-	%
V _{IH}	EN Pin Logic Input Threshold Voltage	Regulator ON	2.0	-	-	V
V _{IL}		Regulator OFF	-	-	0.8	
I _{SH}	EN Pin Input Leakage Current		-	20	-	μA
I _{SL}			-	-10	-	μA
R _{DS(ON)}	Internal MOSFET R _{DS(ON)}		-	80	120	mΩ
I _{LIMIT}	Current Limit		3.5	-	-	A
η	Efficiency	V _{IN} = 12V, V _{OUT} = 5V, I _{OUT} = 2.5A	-	90	-	%
θ _{JA}	Thermal Resistance Junction-to-Ambient	SOP-8L (Note 3)	-	124	-	°C/W
θ _{JC}	Thermal Resistance Junction-to-Case	SOP-8L (Note 3)	-	25	-	°C/W

Notes: 3. Test condition for SOP-8L: Device mounted on 2oz copper, minimum recommended pad layout, FR-4 PCB.

Typical Application Circuit

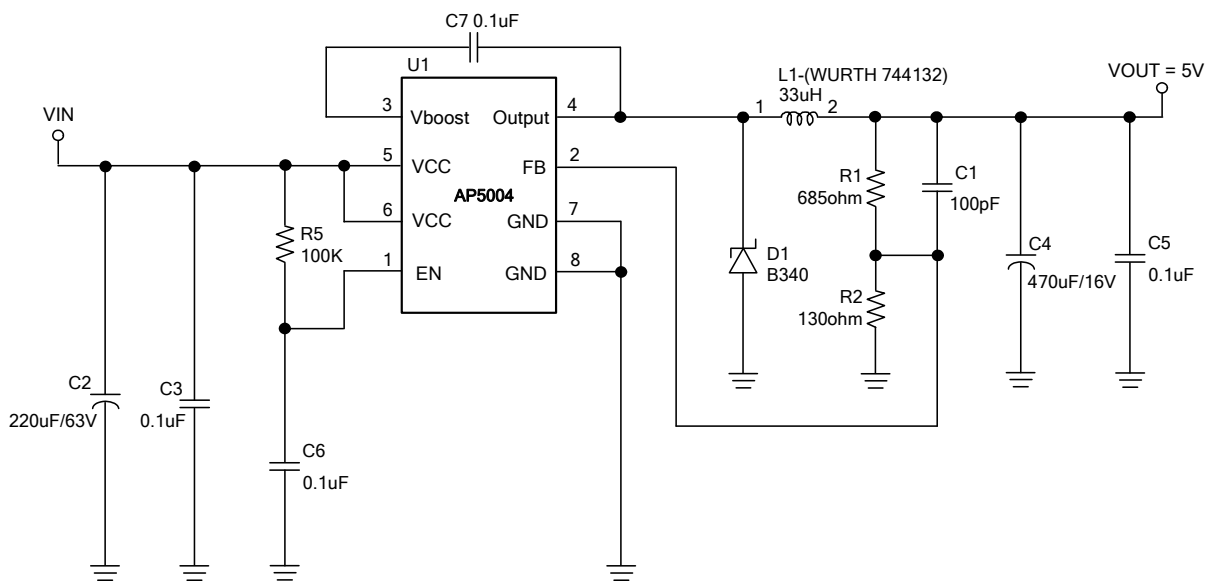

Note: $V_{OUT} = V_{FB} \times (1 + R1/R2)$
 $R_B = 100 \sim 300 \text{ ohm}$

Notes: 4. Suggested DIODES Power Schottky P/N: PDS540 or B540C.

Typical Performance Characteristics

Line Regulation

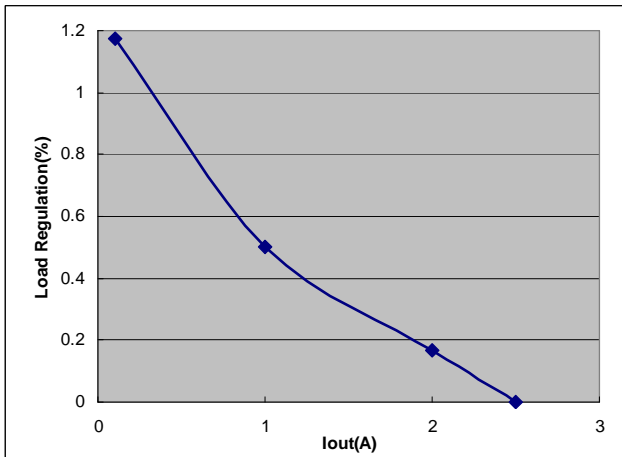

Load Regulation

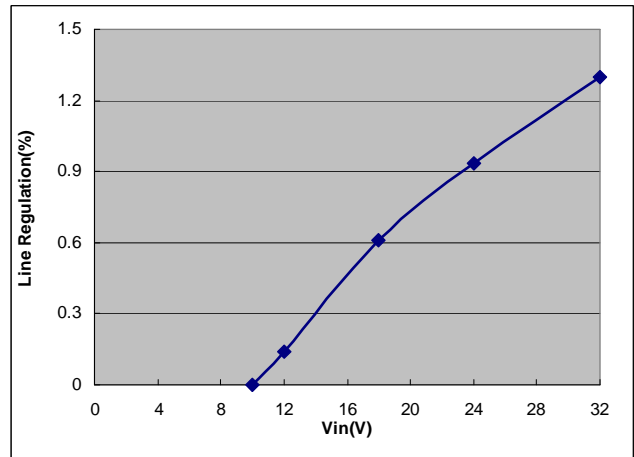

Frequency vs. Vin

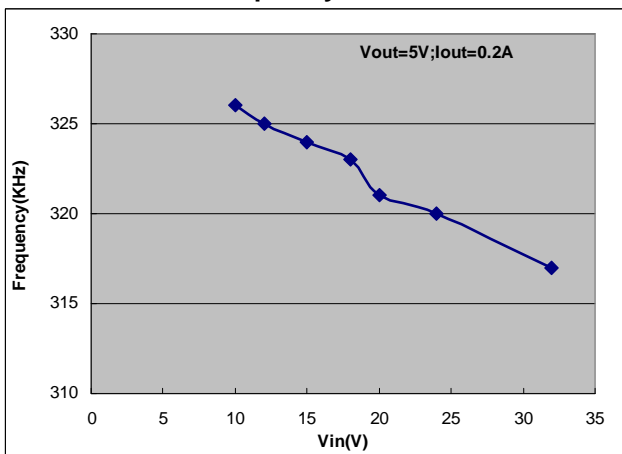

Iccq vs. Vin

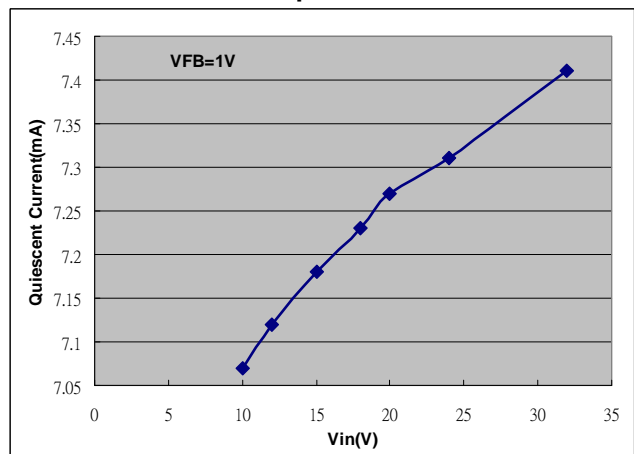

Istandby vs. Vin

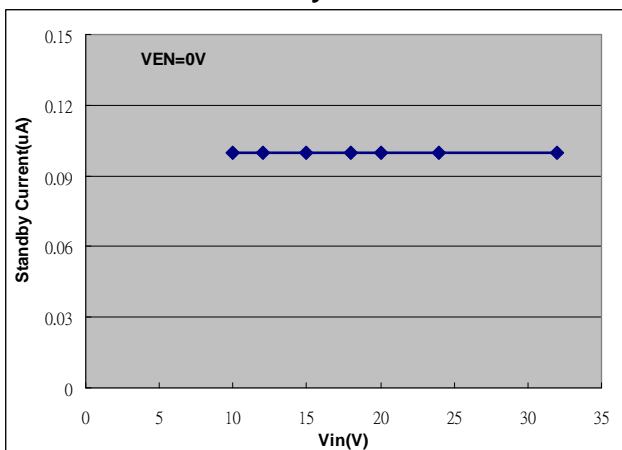

Typical Performance Characteristics (Continued)

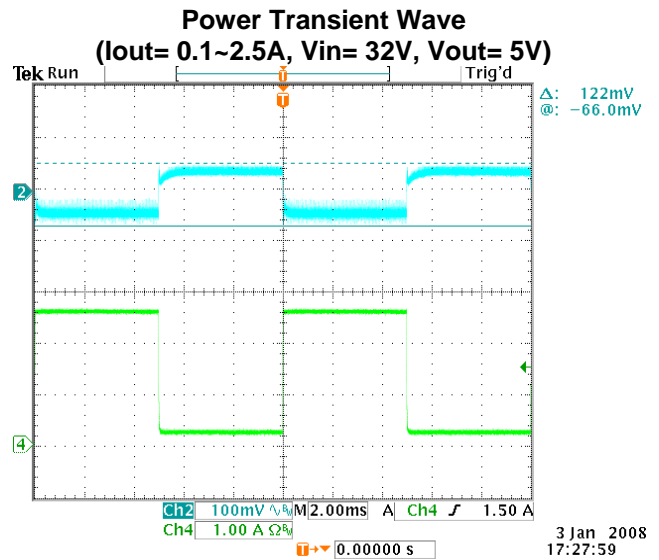
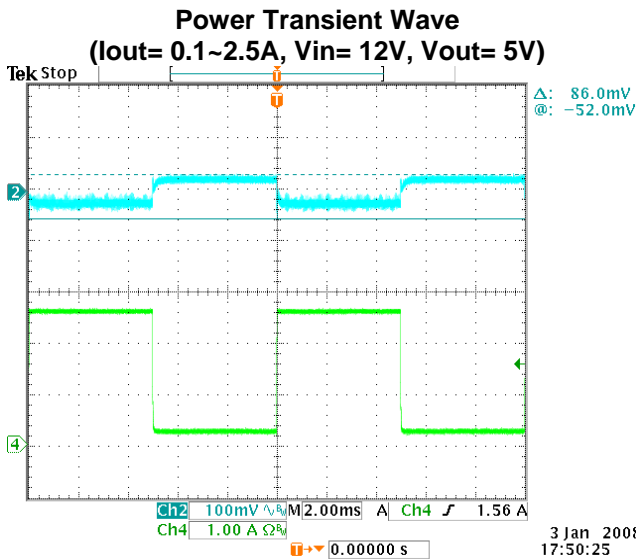
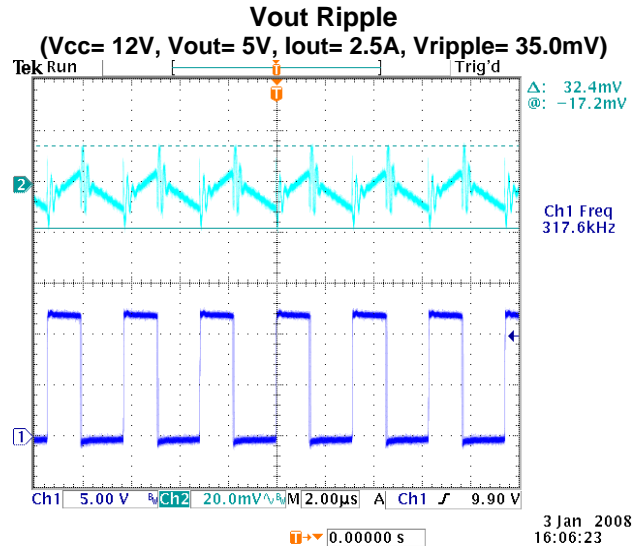
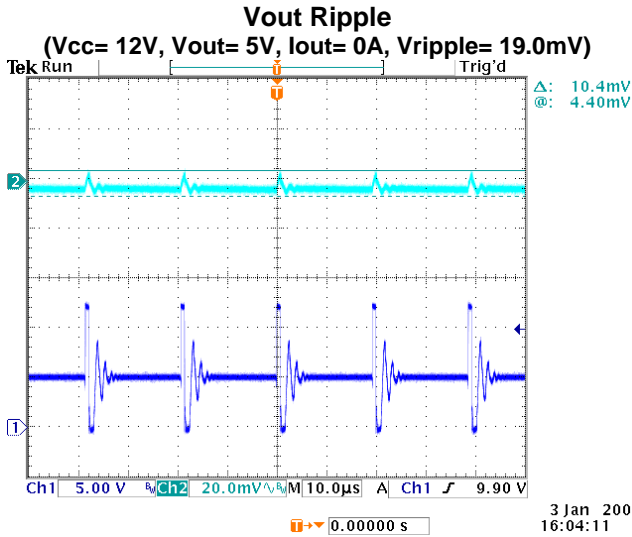

Test Circuit

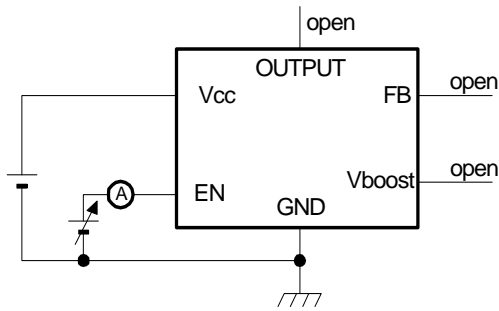

Enable function test

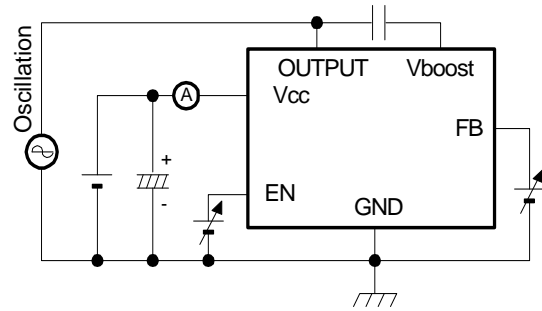

Feedback function test

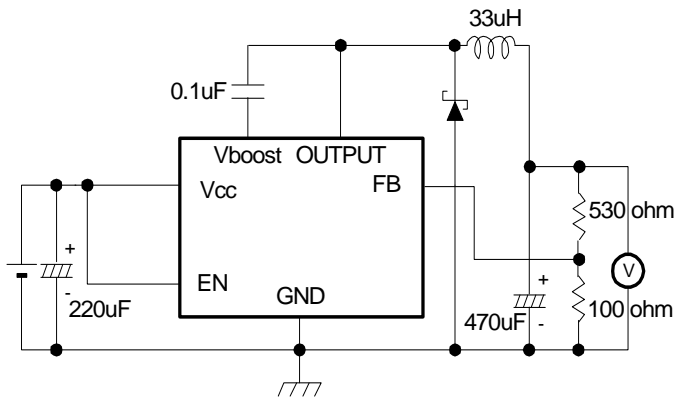

Operation function test

Functional Description

PWM Control

The AP5004 consists of DC/DC converters that employ a pulse-width modulation (PWM) system. The PWM controller is internally clocked by a fixed 300KHz oscillator. In converters of the AP5004, the pulse width varies in a range from 0 to 90%, according to the load current. The ripple voltage produced by the switching can easily be removed through a filter because the switching frequency remains constant. Therefore, these converters provide a low-ripple power over broad ranges of input voltage and load current.

Enable Control

This allows the output of AP5004 to be turned ON or OFF. Connecting this pin to GND or any voltage lower than 0.8V turn off the output OFF. At OFF state current drawn through the V_{CC} input is approximately 2uA. Note that the slew rate from ON to OFF must be $>0.013\text{v/us}$ to ensure proper operation.

C BOOST

A capacitor must be connected from pin 3 to the switch output, pin 4. This capacitor boosts the gate drive to the internal MOSFET above V_{IN} to fully turn it ON. This minimizes conduction losses in the power switch to maintain high efficiency. The recommended value for C Boost is 0.1uF.

FEEDBACK

This is the input to a two-stage high gain amplifier, which drives the PWM controller. It is necessary to connect pin 2 to the actual output of the power supply to set the DC output voltage. Two external resistors are required to set the DC output voltage. For stable operation of the power supply, it is important to prevent coupling of any inductor flux to the feedback input.

Current Limit

The current limit threshold is set by the internal circuit that minimum switching current is 3.5A. The output voltage will be reduced immediately and switching frequency will be dropped to 50KHz when switching current over limit threshold.

Inductor Selection

For most designs, the operates with inductors of 15uH to 33uH. The inductor value can be derived from the following equation:

$$L = \frac{(V_{IN} - V_{OUT})T_{ON}}{\Delta I_L \times f_{osc}}$$

Where is inductor Ripple Current. Large value inductors lower ripple current and small value inductors result in high ripple currents. Choose inductor ripple current approximately 15% of the maximum load current 2.5A, $\Delta I_L=0.375\text{A}$. The DC current rating of the inductor should be at least equal to the maximum load current plus half the ripple current to prevent core saturation $(2\text{A}+0.19\text{A})$.

Input Capacitor Selection

The input current to the step-down converter is discontinuous, and therefore an input capacitor C2 is required to supply the AC current to the step-down converter while maintaining the DC input voltage. A low ESR capacitor is required to keep the noise at the IC to a minimum. Its RMS current rating should be greater than approximately 1/2 of the DC load current.

Output Capacitor Selection

The output capacitor is required to maintain the DC output voltage. Low ESR capacitors are preferred to keep the output voltage ripple low. The characteristics of the output capacitor also affect the stability of the regulation control system. The ESR dominates the impedance at the switching frequency, and so the output ripple is calculated as:

$$V_{RIPPLE} \cong \Delta I \times R_{ESR}$$

Output Rectifier Diode

The output rectifier diode supplies the current to the inductor when the high-side switch is off. To reduce losses due to the diode forward voltage and recovery times, use a Schottky rectifier.

PCB Layout Guide

If you need low T_C & T_J or large PD(Power Dissipation), The dual Output pin(4) and VSS pins(7& 8)on the SOP-8L package are internally connected to die pad, The PCB layout should allow for maximum possible copper area at the SW pins.

1. Connect C3 to VCC and VSS pin as closely as possible to get good power filter effect.
 2. Connect ground side of the C2 & D1 as closely as possible.
- Typical PC Board Layout

Top Side Layout Guide

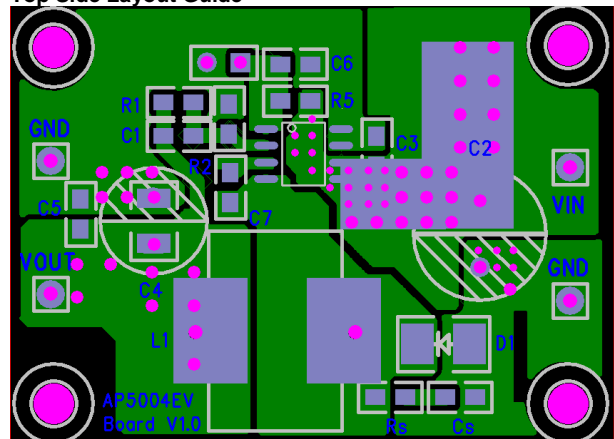

Bottom Side Layout Guide

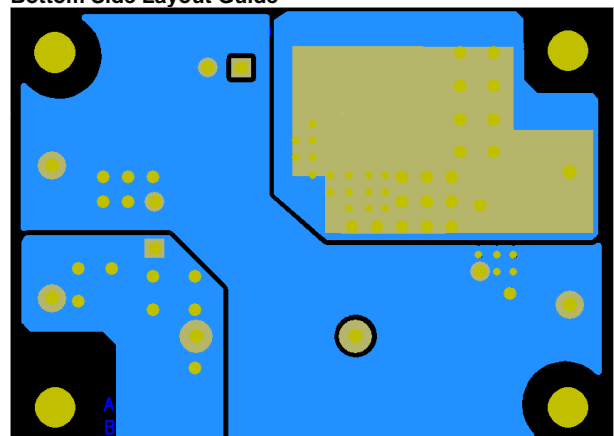

Marking Information

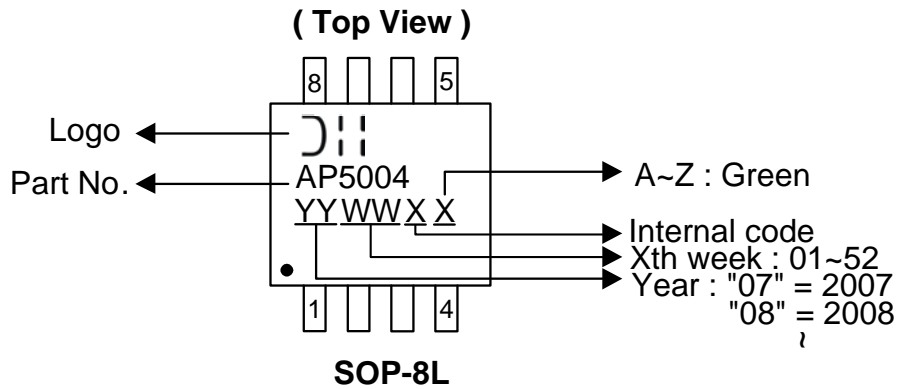

Package Information (All Dimensions in mm)

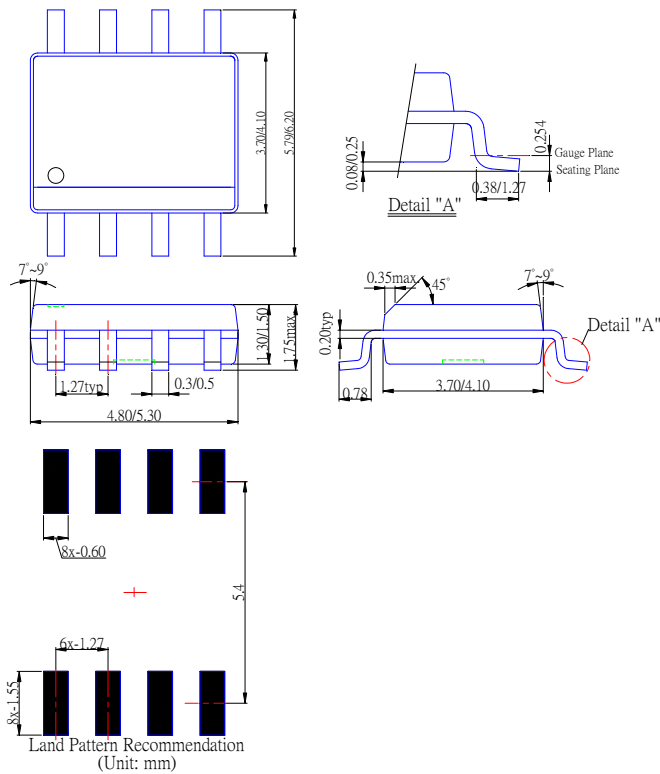

IMPORTANT NOTICE

Diodes Incorporated and its subsidiaries reserve the right to make modifications, enhancements, improvements, corrections or other changes without further notice to any product herein. Diodes Incorporated does not assume any liability arising out of the application or use of any product described herein; neither does it convey any license under its patent rights, nor the rights of others. The user of products in such applications shall assume all risks of such use and will agree to hold Diodes Incorporated and all the companies whose products are represented on our website, harmless against all damages.

LIFE SUPPORT

Diodes Incorporated products are not authorized for use as critical components in life support devices or systems without the expressed written approval of the President of Diodes Incorporated.