

PHEMT GaAs IC High Linearity 3 V T/R SP3T Switch 0.1–2.5 GHz



AS219-321

Features

- +2.6 to +5 V Linear Operation
- Harmonics H₂, H₃ > 70 dBc @ P_{IN} = 34.5 dBm
- Low T_X Insertion Loss (0.35 dB @ 0.9 GHz)
- High R_X Isolation (25 dB @ 0.9 GHz)
- Miniature MLP-12 Plastic Package
- PHEMT Process

Description

The AS219-321 is a PHEMT GaAs IC SP3T antenna switch operating in the 900 MHz and 1800 MHz frequency bands. Switching between the antenna and T_X/R_X ports is accomplished with 3 control inputs. When the control inputs are driven with the appropriate voltages, a low insertion loss path is provided from an antenna port to a T_X port, while the other R_X ports have high attenuation.

MLP-12

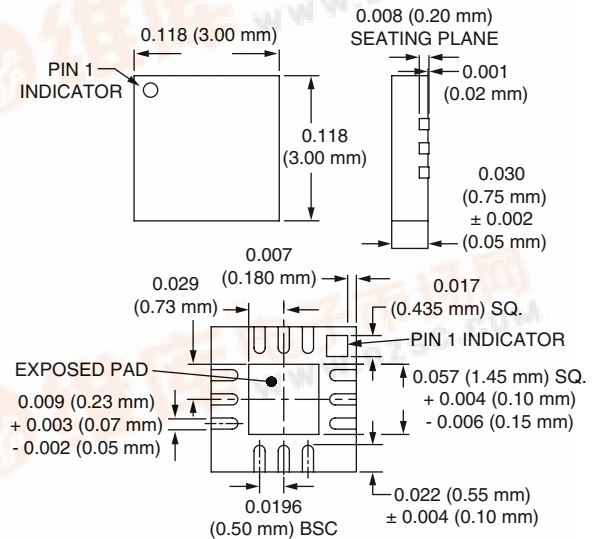

Electrical Specifications at 25°C (0, +3 V)

Parameter ¹	Condition	Frequency	Min.	Typ.	Max.	Unit
Insertion Loss ²	Ant-R _X	0.1–1.0 GHz		0.50	0.75	dB
		1.0–2.0 GHz		0.70	0.80	dB
		2.0–2.5 GHz		0.80	1.10	dB
	Ant-T _X	0.1–1.0 GHz	0.20	0.35	0.40	dB
		1.0–2.0 GHz	0.40	0.50	0.55	dB
		2.0–2.5 GHz	0.55	0.65	0.70	dB
Isolation	Ant-R _X	0.1–1.0 GHz	24	26		dB
		1.0–2.0 GHz	20	25		dB
		2.0–2.5 GHz	20	24		dB
	Ant-T _X	0.1–1.0 GHz	20	23		dB
		1.0–2.0 GHz	14	16		dB
		2.0–2.5 GHz	10	14		dB
VSWR ³		0.1–2.5 GHz		1.1:1		dB

Operating Characteristics at 25°C (0, +3 V)

Parameter	Condition	Frequency	Min.	Typ.	Max.	Unit
Switching Characteristics ⁴	Rise, Fall (10/90% or 90/10% RF)			60		ns
	On, Off (50% CTL to 90/10% RF)			100		ns
	Video Feedthru			50		mV
Input Power for -0.1 dB Compression	0/+3 V	0.9 GHz		+35		dBm
Harmonics H ₂ , H ₃ (Transmit State)	P _{IN} = 34.5 dBm	0.9 GHz, 1.8 GHz		+70		dBc
Control Voltages	V _{Low} = 0 to 0.2 V @ 20 μA Max. V _{High} = +2.7 V @ 100 μA Max. to +5 V @ 200 μA Max.					

1. All measurements made in a 50 Ω system, unless otherwise specified.
2. Insertion loss changes by 0.003 dB/°C.

3. Insertion loss state.

4. Video feedthru measured with 1 ns risetime pulse and 500 MHz bandwidth.

Typical Performance Data

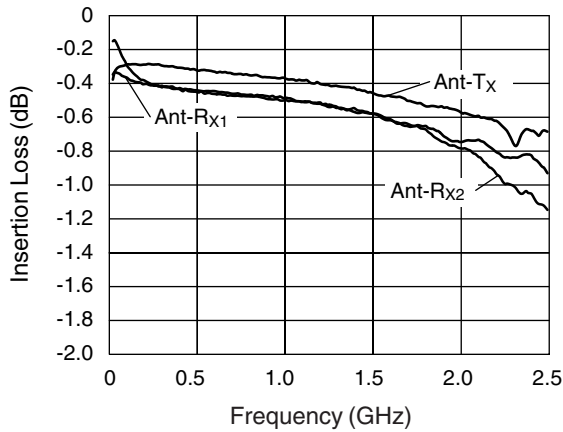

Insertion Loss vs. Frequency

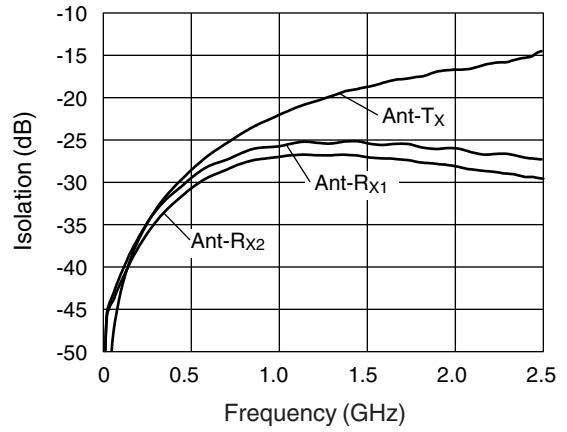

Isolation vs. Frequency

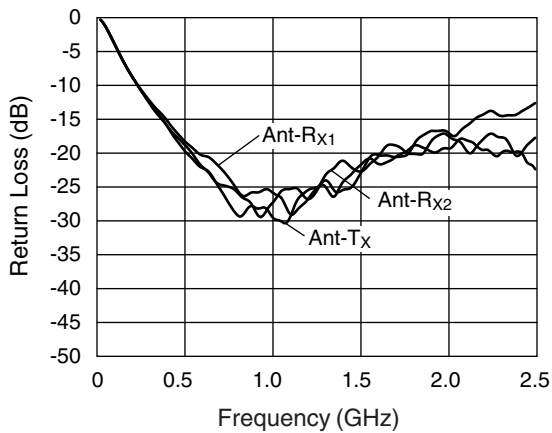

Return Loss vs. Frequency

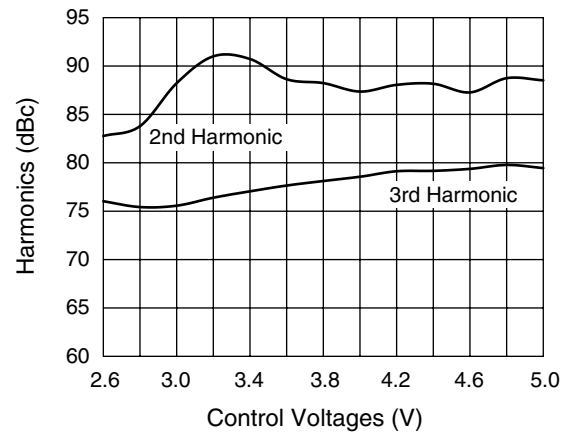

0.9 GHz Harmonics vs. Control Voltages

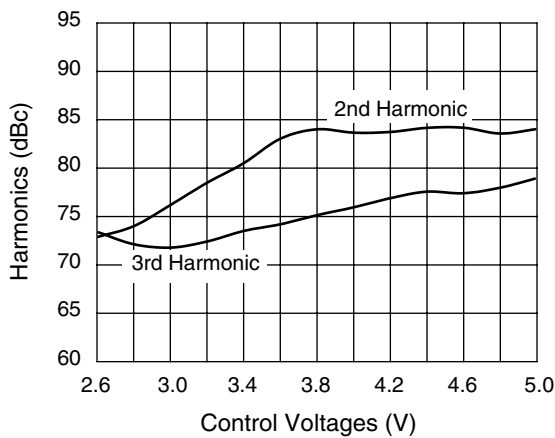

1.8 GHz Harmonics vs. Control Voltages

Truth Table

V ₁	V ₂	V ₃	Ant-T _X	Ant-R _{X1}	Ant-R _{X2}
V _{High}	V _{Low}	V _{Low}	Ins. Loss	Isolation	Isolation
V _{Low}	V _{High}	V _{Low}	Isolation	Ins. Loss	Isolation
V _{Low}	V _{Low}	V _{High}	Isolation	Isolation	Ins. Loss

V_{Low} = 0–0.2 V.
V_{High} = 2.75–5 V.

Pin Out (Top View)

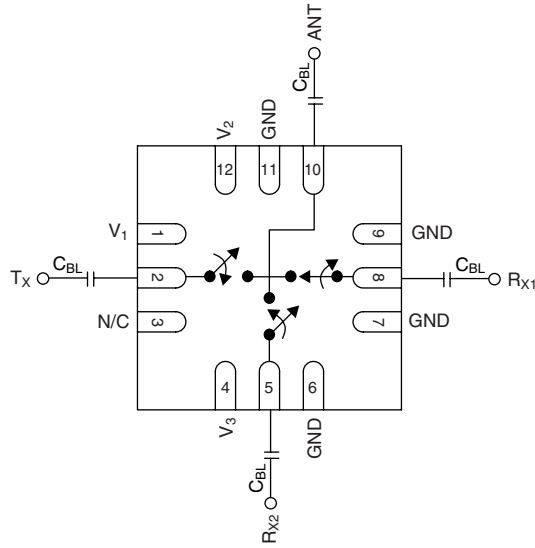

DC blocking capacitors (C_{BL}) must be supplied externally for positive voltage operation.
 $C_{BL} = 47 \text{ pF}$ for operation $>500 \text{ MHz}$.

Absolute Maximum Ratings

Characteristic	Value
RF Input Power	6 W > 500 MHz 0/+7 V Control
Control Voltage	-0.2 V, +8 V
Operating Temperature	-40°C to +85°C
Storage Temperature	-65°C to +150°C
Θ_{JC}	25°C/W