

# PHEMT GaAs IC High Power SP4T Switch 0.1–2.5 GHz



AS221-306

## Features

- 4 Symmetric RF Paths
- Positive Voltage Control @ 2.6 V
- High IP3
- Excellent Harmonic Performance
- Handles GSM Power Levels
- Available in MLF-16 (4 x 4 mm) Package

## Description

The AS221-306 is a reflective SP4T switch. It is an ideal switch for higher power applications. It can be used for GSM dual-band handset applications where both low loss, low current and small size are critical parameters.

## QFN-16 (4 x 4 mm)

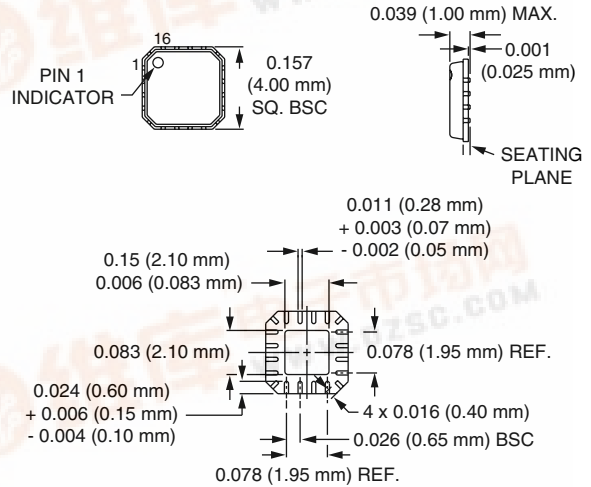

## Electrical Specifications at 25°C (0, +2.6 V)

Parameter	Frequency	Min.	Typ.	Max.	Unit
Insertion Loss	Ant-J <sub>1</sub> , J <sub>2</sub> , J <sub>3</sub> , J <sub>4</sub>	0.1–0.5 GHz	0.6	0.7	dB
		0.5–1.0 GHz	0.7	0.8	dB
		1.0–2.0 GHz	0.9	1.1	dB
		2.0–2.5 GHz	1.1	1.2	dB
Isolation	Ant-J <sub>1</sub> , J <sub>2</sub> , J <sub>3</sub> , J <sub>4</sub>	0.1–0.5 GHz	30	34	dB
		0.5–1.0 GHz	25	29	dB
		1.0–2.0 GHz	19	23	dB
		2.0–2.5 GHz	18	22	dB
VSWR		0.1–1.0 GHz		1.2:1	
		1.0–2.5 GHz		1.3:1	

## Operating Characteristics at 25°C (0, +2.6 V)

Parameter	Condition	Frequency	Min.	Typ.	Max.	Unit
Switching Characteristics	Rise, Fall (10/90% or 90/10% RF)			50		ns
	On, Off (50% CTL to 90/10% RF)			100		ns
	Video Feedthru			50		mV
IP3	13 dBm/Tone			+55		dBm
2nd and 3rd Harmonics	34 dBm Input 900 MHz			+65		dBc
Control Voltages	V <sub>Low</sub> = 0 V <sub>High</sub> = 2.6 V @ 200 μA					



### Typical Performance Data

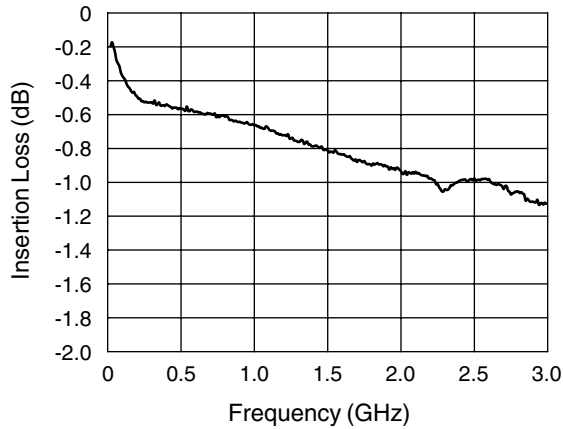

Typical Insertion Loss vs. Frequency

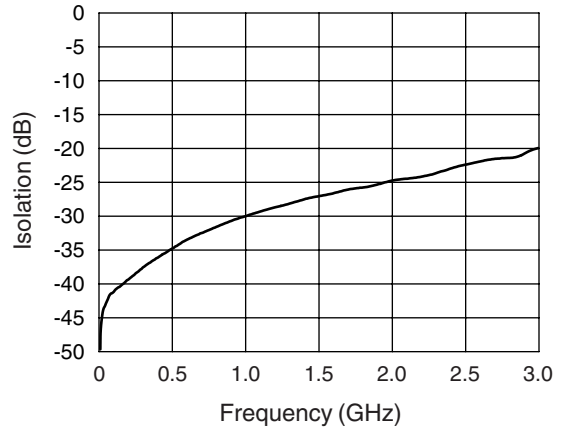

Typical Isolation vs. Frequency

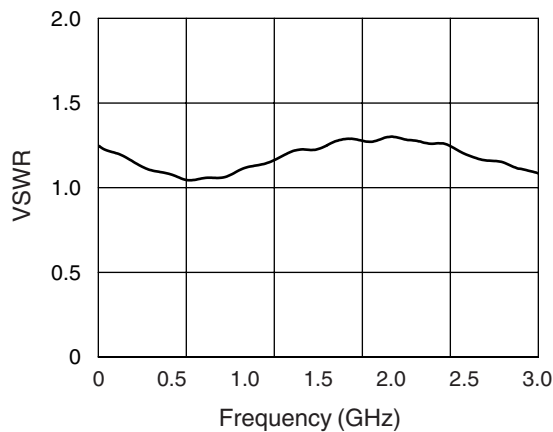

Typical VSWR vs. Frequency

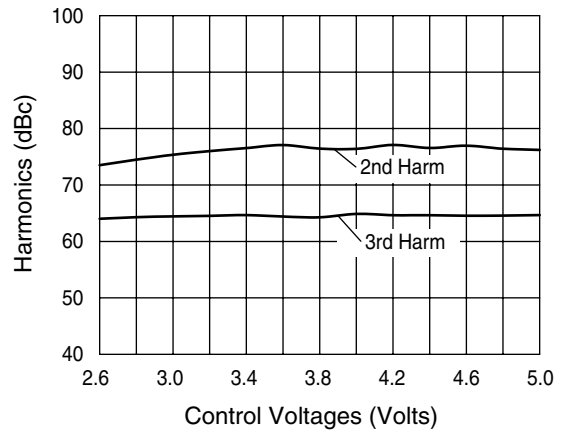

Typical Harmonics vs. Control Voltages

### Absolute Maximum Ratings

Characteristic	Value
RF Input Power	4 W > 0.5 GHz 0/+6 V Control
Control Voltage	+6 V
Operating Temperature	-40°C to +85°C
Storage Temperature	-65°C to +150°C
$\Theta_{JC}$	25°C/W

### Truth Table

V <sub>1</sub>	V <sub>2</sub>	V <sub>3</sub>	V <sub>4</sub>	Ant-J <sub>1</sub>	Ant-J <sub>2</sub>	Ant-J <sub>3</sub>	Ant-J <sub>4</sub>
V <sub>High</sub>	V <sub>Low</sub>	V <sub>Low</sub>	V <sub>Low</sub>	Ins. Loss	Isolation	Isolation	Isolation
V <sub>Low</sub>	V <sub>High</sub>	V <sub>Low</sub>	V <sub>Low</sub>	Isolation	Ins. Loss	Isolation	Isolation
V <sub>Low</sub>	V <sub>Low</sub>	V <sub>High</sub>	V <sub>Low</sub>	Isolation	Isolation	Ins. Loss	Isolation
V <sub>Low</sub>	V <sub>Low</sub>	V <sub>Low</sub>	V <sub>High</sub>	Isolation	Isolation	Isolation	Ins. Loss

V<sub>Low</sub> = 0.  
V<sub>High</sub> = 2.6 V.

### Pin Out

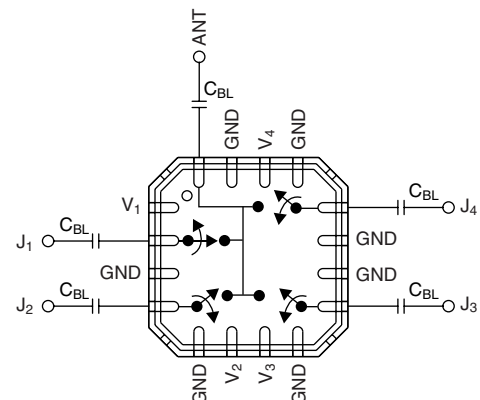

DC blocking capacitors (C<sub>BL</sub>) must be supplied externally.  
C<sub>BL</sub> = 47 pF for operating frequency >500 MHz.