



Austria Mikro Systeme International AG

# Telephone Speech Circuit with Loudhearing and Handsfree

## Key Features

- ❑ Line/speech circuit, loudhearing, handsfree and dc/dc converter on one 28 pin CMOS chip
- ❑ Operating range from 13 to 100 mA (down to 5 mA with reduced performance)
- ❑ Soft clipping control eliminating harsh distortion
- ❑ Volume control of receive signal with squelch and automatic loop gain compensation
- ❑ Line loss compensation pin selectable
- ❑ Low noise (max. - 72 dBmp)
- ❑ Real or complex impedance adjustable
- ❑ NET 4 compatible
- ❑ Dynamically controlled voice switching
- ❑ Same monitor amplifier for loudhearing, handsfree and tone ringer
- ❑ Very few external components
- ❑ Power derived from ring signal by switching converter during ringing

## General Description

The AS2520/21/20B/21B are CMOS integrated circuits that contain all the audio functions needed to form a high comfort, line-powered telephone.

The devices incorporate line adaptation, speech circuit, loudhearing and handsfree - all supervised by the novel voice and power control circuit. A switching converter is also provided for converting the ring signal. The interface to a dialler/controller is made very simple to allow easy adaptation to a telecom microcontroller.

The AS2520 series incorporate volume control for the earpiece and the loudspeaker (AS2520 digital with +/- keys and AS2521 analogue with potentiometer). The volume control circuit automatically compensates the loop gain to ensure acoustic stability.

## Typical Application

## Package

Available in 28 pin SOP and DIP.

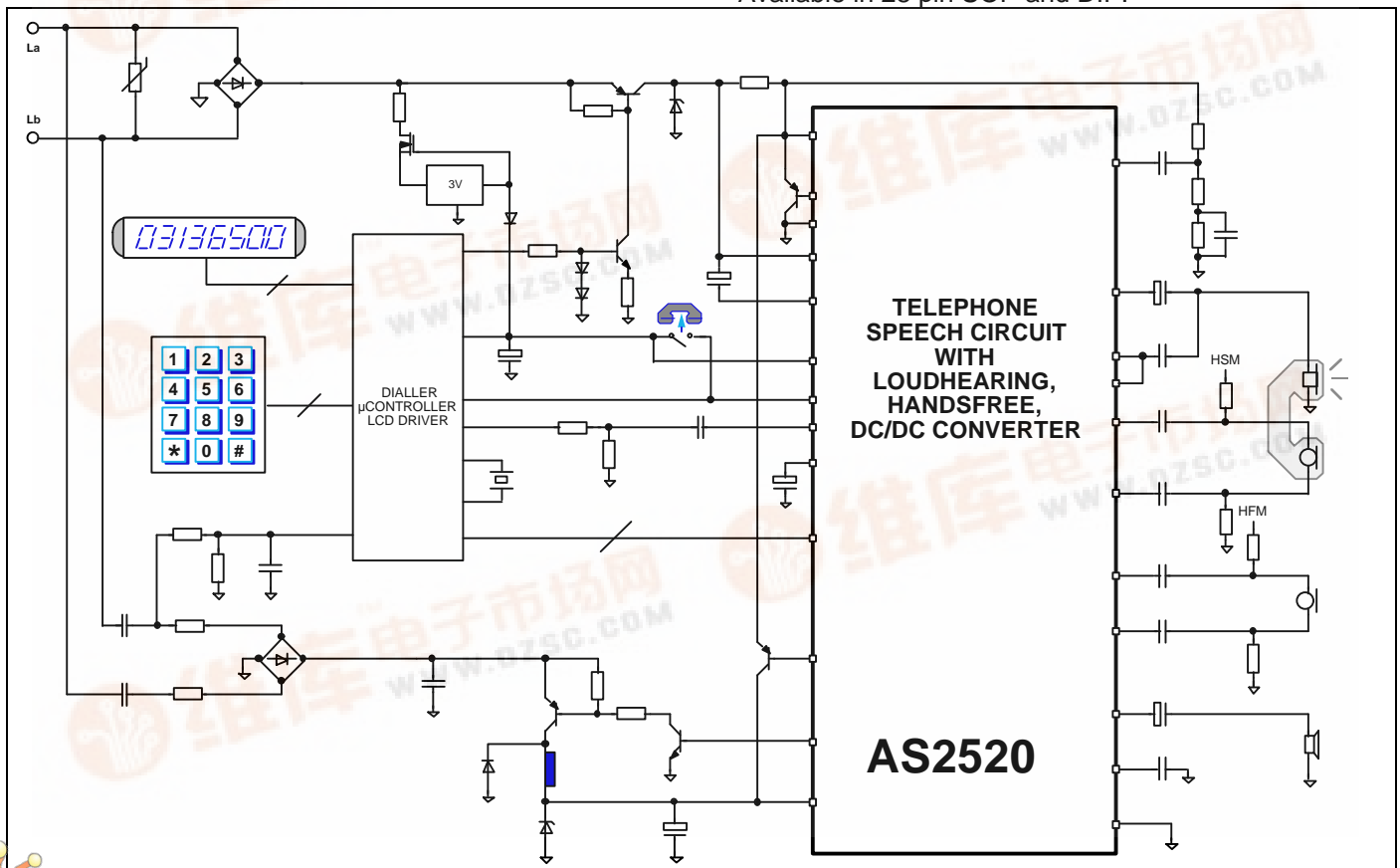

Figure 1: Typical Handsfree Telephone Application



## Pin Description

Pin #	Name	Type	Description
1	LS	AI	<b>Line Current Sense Input</b> This input is used for sensing the line current.
2	CI	AI	<b>Complex Impedance Input</b> Input pin for the capacitor in the complex impedance.
3	RO	AO	<b>Receive Output</b> This is the output for driving a dynamic earpiece with an impedance of 140 to 300 ohm.
4	V <sub>DD</sub>	Supply	<b>Positive Voltage Supply</b> This is the supply pin for the circuit.
5	A <sub>GND</sub>	Supply	<b>Analogue Ground</b> This pin is the analogue ground for the amplifiers.
6	STB	AI	<b>Side Tone Balance Input</b> This is the input for the side tone cancellation network.
7	LLC	DI	<b>Line Loss Compensation Selection Pin</b> LLC = V <sub>DD</sub> : High range      -6 dB from 45 mA to 75 mA; LLC = A <sub>GND</sub> : Low range      -6 dB from 20 mA to 50 mA; LLC = V <sub>SS</sub> : No regulation      gain independent of line current;
8	LSI	AO	<b>Loudspeaker Amplifier Input</b> This is the input for applying the receive signal to the loudspeaker amplifier.
9	TI	AI DI	<b>Tone Input</b> This switchable input is intended for transmitting DTMF or other signals like messages on TAMs (Telephone Answering Machines) onto the line in off-hook conditions and when in ringing mode to apply a PDM signal to the loudspeaker (see also table 1).
10	RTH	AI	<b>Receive Threshold Input</b> The sensibility of the receive peak detector can be adjusted by applying the signal from RO to the RTH input through a voltage divider.
11	CM	AO	<b>Converter Make Output</b> This is an output for controlling the external switching converter. It converts the ring signal into a 4V supply voltage and is activated when PD = high and HS, LE, MT = low.
12	V <sub>PP</sub>	Supply	<b>Loudspeaker Power Supply</b> High power supply for the output driver stage.
13	LO	AO	<b>Output for Loudspeaker</b> Output pin for an ac coupled 32 Ω (25 to 50 Ω) loudspeaker.
14	V <sub>SSP</sub>	Supply	<b>Negative High Power Supply</b> This pin is the negative high power supply for the loudspeaker amplifier.
15	MT	DI	<b>Mute Input</b> Dialling mute input (see also table 1). MT = V <sub>DD</sub> : Tx and Rx channels muted; MT = V <sub>SS</sub> : Tx and Rx channels <u>not</u> muted.
16	PD	DI	<b>Power Down Input</b> Input for powering down the speech circuit and loudhearing/handsfree (see table 1).
17	LE	DI	<b>Loudhearing Enable Input</b> Input for enabling loudhearing/handsfree, active high (see table 1).
18	HS	DI	<b>Handset Switch Input</b> This is an input that is pulled high by the hook switch (handset) or μC when off-hook (see table 1).

19	M1	AI	<b>Microphone Inputs</b> Differential inputs for handset microphone (electret).
22	M2		
20	M4	AI	<b>Handsfree Microphone Inputs</b> These are the input pins for the handsfree microphone (electret).
21	M3		
23	VOL	D/AI	<b>Volume Control Input</b> Volume control for the receive signal. AS2520: Digital control with +/- keys or from $\mu\text{C}$ ; AS2521: Analogue dc control with potentiometer.
24	SS	AO	<b>Supply Source Control Output</b> This N-channel open drain output controls the external high power source transistor for supplying ( $V_{PP}$ ) the loudspeaker amplifier in off-hook loudhearing/handsfree mode.
25	CS	AO	<b>Current Shunt Control Output</b> This N-channel open drain output controls the external high power shunt transistor for the modulation of the line voltage and for shorting the line during make period of pulse dialling.
26	$V_{SS}$	Supply	<b>Negative Power Supply</b>
27	LI	AI/O	<b>Line Input</b> This input is used for power extraction and line current sensing.
28	RI	AI	<b>Receive Input</b> This is the input for the receive signal.

DI: Digital Input

AI: Analogue Input

DO: Digital Output

AO: Analogue Output

DI/O: Digital Input/Output

AI/O: Analogue Input/output

## Operating Modes

MODE	I/O Pins				Digital Inputs		Tone Input		Outputs			
	HS	LE	PD	MT	TI		CM	LI	RO	LO		
Idle (on-hook)	0	0	0	0	Not connected		Low	-	PD	PD		
Ringing	0	0	1	0	PDM signal to LO (DI)		SW	-	-	'TI'		
POT	1	0	0	0	Not connected		Low	'M1/M2'	'RI/STB'	-		
POT/pulse dialling	1	0	1	1	Not connected		Low	$V_{BE}$	-	-		
POT/DTMF dialling	1	0	0	1	DTMF to LI and RO (AI)		Low	'TI'	'TI'	-		
Handsfree	0	1	0	0	Not connected		Low	'M3/M4'	'RI/STB'	'LSI'		
Handsfree/pulse dial	0	1	1	1	Not connected		Low	$V_{BE}$		-		
Handsfree/DTMF dial	0	1	0	1	DTMF to LI and RO (AI)		Low	'TI'		'LSI'		
Loudhearing	1	1	0	0	Not connected		Low	'M1/M2'	'RI/STB'	'LSI'		
Loudhearing/pulse dial	1	1	1	1	Not connected		Low	$V_{BE}$				
Loudhearing/DTMF dial	1	1	0	1	DTMF to LI and RO (AI)		Low	'TI'		'LSI'		
TAM without LSP	1	0	1	0	Signal to LI (AI)		Low		'RI/STB'			
TAM with LSP	1	1	1	0	Signal to LI (AI)		Low		'RI/STB'	'LSI'		
Melody feedback	0	1	1	0	PDM signal to LO (DI)		Low		'RI/STB'			
Test mode 1	0	0	0	1	Reserved for testing							
Test mode 2	0	0	1	1	Reserved for testing							

Table 1: Operating Modes

### Functional Description

The AS252x contains all the voice circuits needed in a high feature telephone instrument, i.e.:

- line adaptation (ac impedance, dc characteristics, 2/4-wire conversion, power extraction)
- handset speech circuit
- loudhearing with enhanced anti-Larsen
- handsfree with dynamic loop gain control
- switching converter

The line adaptation includes line driver, ac impedance (return loss), 2 to 4 wire converter, dc mask and power extraction circuit for extracting the maximum dc power from the line to supply the whole device and peripheral circuits.

The handset speech circuit consists of a transmit and a receive path with mute, dual soft clipping and line regulation (pin option). A volume control is provided with squelch and loop gain compensation to improve signal-to-noise ratio and to assure acoustic stability.

Loudhearing and handsfree functions are also provided. The loudhearing function includes an anti-Larsen circuit to prevent acoustic howling.

The handsfree circuit has a novel voice control system which is virtually independent of any background noise and works in a dynamic half duplex mode as close to full duplex as the acoustic loop gain allows.

The switching converter is used to extract the available power from the ring signal and provides a 4V supply voltage. This allows the same loudspeaker to be used for loudhearing/handsfree and tone ringing.

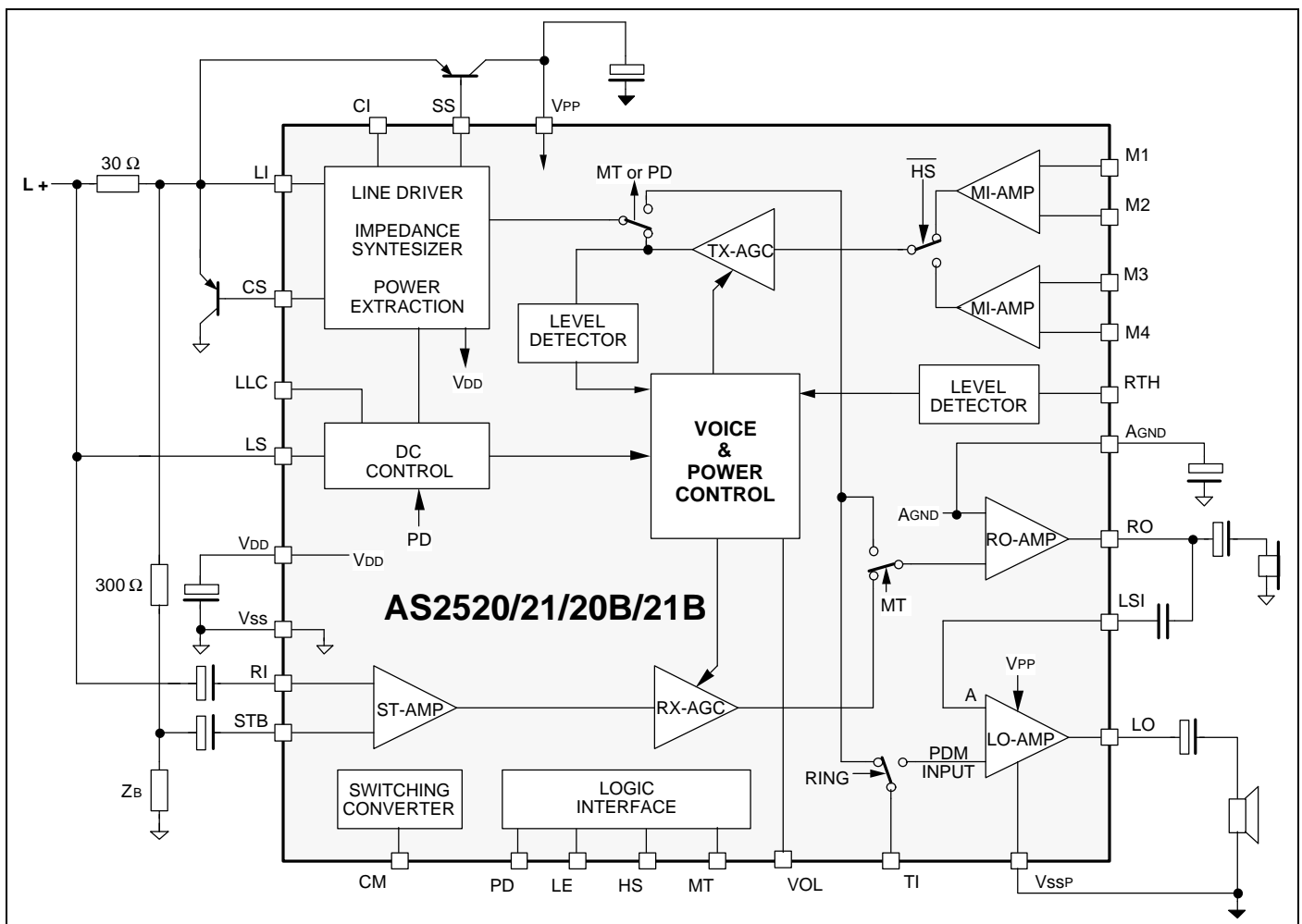

Figure 2: Block Diagramme

## DC Conditions

The normal operating range (off-hook) is from 13 mA to 100 mA. Operating range with reduced performance is from 5 mA to 13 mA (parallel operation). In the normal operating range all functions are operational.

In the line hold range from 0 to 5 mA the device is in a power down mode and the voltage at LI is reduced to maximum 3.5V.

The dc characteristic (excluding diode bridge) is determined by the voltage at LI and the resistor R1 at line currents above 13 mA as follows:

$$V_{LS} = V_{LI} + I_{LINE} \times R1$$

The voltage at LI is 4.5V.

Below 13 mA the AS252x provides an additional slope in order to allow parallel operation (see figure 3).

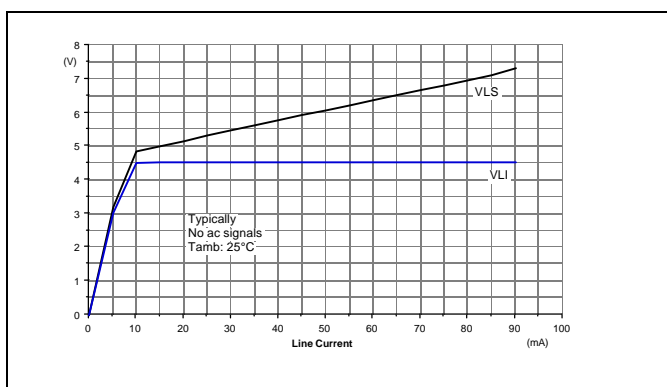

Figure 3: DC Mask

When the PD pin is high (during pulse dialling) the speech circuit and other part of the device not operating are in a power down mode to save current. The CS pin is pulled to  $V_{SS}$  in order to turn the external shunt transistor on to keep a low voltage drop at the LS pin during make periods.

## AC Impedance

The synthesised ac impedance of the circuit is set on chip and by an external resistor and an external capacitor (for complex impedance).

When R1 is set to 30 ohm, the ac impedance is 1000 ohm real, and the complex part can be set by a capacitor connected to pin 2 (CI).

For 600 ohm telephones it is recommended to connect a resistor and a capacitor from pin LS to  $V_{SS}$

(see application notes). The dc resistance of R1 should be kept at 30 ohm to ensure correct dc condition.

Return loss and sidetone cancellation can be determined independent of each other (see figure 4).

## Speech Circuit

The speech circuit consists of a transmit and a receive path with soft clipping, mute, line loss compensation and sidetone cancellation.

### Transmit

The gain of the transmit path is 36.5 dB in handset mode (from M1/M2 to LS) and 46.5 dB in handsfree mode (from M3/M4 to LS). The microphone inputs have an input impedance of 15 kohm.

The unique dual soft clipping control circuit limits the output voltage at LI to  $2V_{PEAK}$ . Dual means that the soft clipping incorporates both a very fast control circuit to eliminate harsh sidetone distortion and a slower regulation circuit to limit the output voltage at  $2V_{PEAK}$  independent of the line impedance. The attack time is 30  $\mu$ s/6 dB. The overdrive range is 30 dB. When mute is active, pin MT high, the gain is reduced by > 60 dB.

### Receive

The gain of the receive path is 3 dB (test circuit figure 8) from RI to RO. The receive input is the differential signal of RI and STB. Also the receive channel provides soft clipping to avoid acoustic shock and harsh distortion.

When mute is active during dialling the gain is reduced by > 60 dB. During DTMF dialling a MF comfort tone is applied to the receiver. The comfort tone is the DTMF signal with a level that is -30 dB relative to the line signal.

### Volume Control

On the AS2520 the receive gain can be changed by pressing the volume keys. The + key increases the gain by 10 dB in 5 steps and the - key decreases the gain by 10 dB in 5 steps. The gain is reset by next off-hook. The volume can also be controlled via a microcontroller.

The AS2521 uses a potentiometer to control the receive gain. The volume is an indirect dc control to avoid that noise is introduced from the potentiometer.

The volume control is common for both the earpiece and the loudspeaker. Any increase will be compensated to ensure acoustic stability.

The acoustic stability is provided as follows:

When the volume is increased, e.g. by 10 dB, the receive gain maintains the same as long as no receive signal is applied. Applying a receive signal will cause a 10 dB increase of the receive gain and a corresponding decrease of the transmit gain. This squelch function improves the signal-to-noise ratio.

In other words, a certain increase of the volume introduces a similar amount of dynamic voice switching, controlled by the receive signal, also in the handset mode.

Sidetone

A good sidetone cancellation is achieved by using the following equation:

$$Z_{BAL}/Z_{LINE} = R5/R1$$

The sidetone cancellation signal is applied to the STB input.

By using two separate Wheatstone Bridges for return loss and sidetone cancellation it is very easy to calculate the sidetone balance network (see figure 4). This unique configuration provides a sidetone cancellation less sensitive to tolerances on the external balance network and totally independent of the ac impedance and its tolerances.

A good and stable sidetone cancellation improves the handsfree function considerably and ensures a safe margin against acoustic instability under all circumstances.

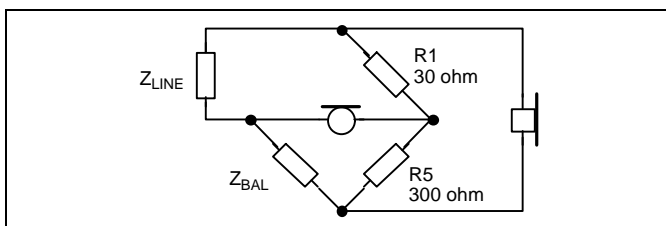

Figure 4: Sidetone Bridge

Furthermore, the dual Wheatstone bridge makes it very simple to adapt the circuit to different PTT requirements as these two parameters (return loss and sidetone balance) are independent of each other.

Line Loss Compensation

The line loss compensation (Rx and Tx AGC controlled by the line current) is a pin option. When it is activated, the transmit and receive gains are changed by -6 dB in 1 dB steps at line currents from

20 to 50 mA or 45 to 75 mA depending on selected range.

Loudhearing

The loudhearing mode is enabled when HS and LE are high. In order to prevent acoustic coupling between the handset microphone and the loudspeaker, the AS252x incorporate an anti-Larsen circuit.

The anti-Larsen circuit decreases the gain of the loudspeaker amplifier when a microphone signal is applied. If no signal is applied from the microphone, the loudspeaker amplifier is at its full gain.

Anti-Clipping (not AS2520B/21B)

The anti-clipping circuit is activated in loudhearing and handsfree mode. The circuit prevents harsh distortion at very high signal levels.

Furthermore, the circuit assures that the integrity of the whole telephone circuit is maintained under extreme load conditions, since it prevents that the supply voltage drops below a certain minimum level.

The attack time is fast (120 μs/6 dB) for preventing harsh distortion when the amplitude rapidly increases. For avoiding chopper effects and to assure low distortion, the decay time is longer, approx. 128 ms/6 dB.

When the anti-clipping circuit has been activated by a large receive signal, the channel control will increase the Tx gain corresponding to the reduction in Rx gain caused by the anti-clipping.

Handsfree

The handsfree function allows voice communication without using the handset (full 2-way speaker phone). Two voice controlled attenuators prevent acoustic coupling between the loudspeaker and the microphone.

A conventional voice switching circuit has a channel control with three states, namely idle, transmit or receive. In idle state, when no signal is applied, both the transmit and the receive channels are attenuated by approx. 20 dB to keep the total loop gain below 0 dB.

When a signal is applied to the microphone, the circuit switches to transmit state, i.e. the gain in the transmit channel is increased and the gain in the receive channel is decreased accordingly. And vice versa when a receive signal is applied.

This approach has some disadvantages. It requires a high degree of discipline, since the three state channel control gives a very distinct half duplex with a relative high switching time constant to avoid chopper effects. Furthermore, the system is very sensitive to the environment,- noise, line conditions and acoustics (echo).

Apart from keeping a distinct discipline, the user can not do anything to minimise the effect of these constraints, since the parameters of the voice switching (thresholds, time constants, noise discrimination, etc.) can not be changed or adapted to the actual conditions by the user.

The dynamic voice control system of the AS252x have been designed to overcome the above constraints. The basic philosophy behind the AS252x is that telephone circuits should not have any automatic regulations preventing the user from having all information about the actual conditions which should enable her/him to act accordingly, i.e. to comply with the given constraints.

Now, assuming subscriber A has a handsfree telephone and is calling subscriber B, who has a normal telephone. The B subscriber does not necessarily know that A is using a handsfree telephone and will therefore not automatically comply to the discipline of a half duplex conversation. Hence, the disadvantages by using half duplex should apply to the A subscriber only.

Secondly, if A is in a noisy environment, the B subscriber should hear it, so that he speaks up to increase the signal-to-noise ratio at the A subscriber.

The traditional 3-state switching system has two major drawbacks: first of all, when no one is talking, the circuit is in idle state and the B subscriber gets the feeling that the line is dead, since the background noise does not activate the voice switching. Secondly, the B subscriber does not speak up, since she/he does not hear the background noise.

The concept of the AS252x, however, does not exclude the human factor, but provides the information about the actual conditions to the user and allows her/him to act accordingly, i.e. to speak up, to change the volume, etc.

In more technical terms, the AS252x works in the following manner:

When no signal is applied neither from the line nor from the microphone, the circuit is in the only static state, which is transmit channel full open and receive channel attenuated by up to 30 dB.

The advantages of using the transmit state as the static (idle) state are that the B subscriber hears an open line (the line is not dead), does not miss the initial word of a sentence when the A subscriber starts talking, and hears the level of the background noise at A's end which will actuate her/him to speak up accordingly.

When the A subscriber starts talking, the circuit remains in the static state.

The dynamic state of the voice switching can only be activated by the receive signal. Applying a receive signal above a certain level will cause the circuit to enter the dynamic state.

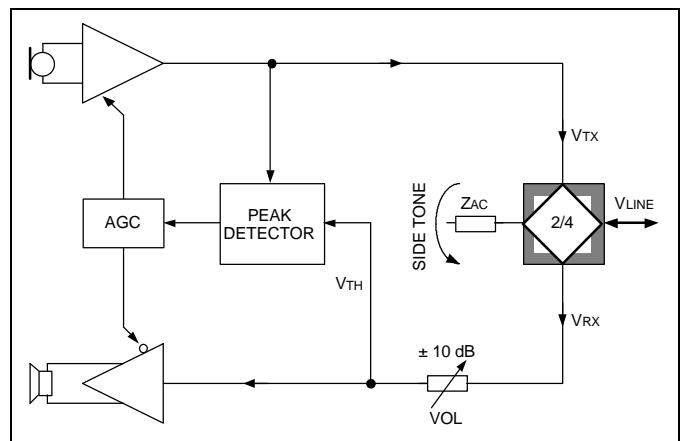

Figure 5: Channel Control System

The signal for controlling the channel attenuation is taken after the sidetone amplifier. With the volume at 0 dB (neutral) the threshold for entering the dynamic state ( $V_{TH}$ ) is 15 mV assuming that  $V_{RX} > V_{TX}$  (see figure 5).

In the dynamic state the channel attenuation is controlled by a voltage controlled amplifier. The attack time is 4 ms/6 dB and the hold time is 200 ms.

A speech compression is activated when a transmit signal with a high amplitude reaches a level corresponding to approximately 460 mV on the line.

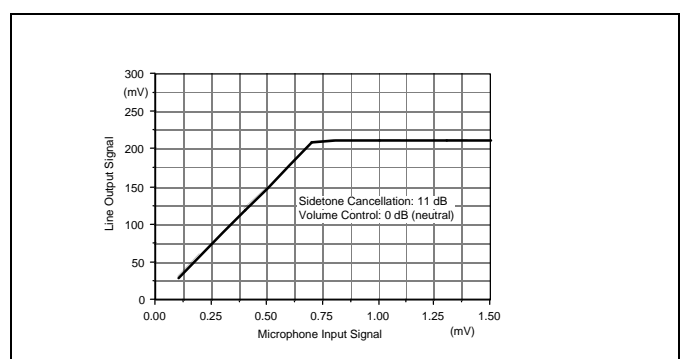

Figure 6: Speech Compression

The speech compression allows a higher gain in the transmit channel, i.e. the microphone gets more sensitive at low sound pressure levels on the microphone, which enables the user to move further away from the telephone. This means that a constant signal is provided on the line practical independent of the microphone signal level. Any reduction of gain by the compressor in the transmit channel will automatically be given to the receive channel.

**Switching Converter**

The ac ringing signal is utilised to extract the power necessary to the tone ringer circuit. A switch mode power supply is used to obtain a high efficiency dc conversion.

This approach allows the use of the same loudspeaker and amplifiers for both loudhearing and tone ringing. It also allows an acoustic feedback of the melodies during programming with the same sound pressure level as during ringing.

When a ringing signal is applied, PD is pulled high and the oscillator is enabled. The switching converter is controlled by the output CM, which is turned high and low with a duty cycle controlled by the voltage at  $V_{PP}$ .

When off-hook the switching converter has a high impedance (CM low) to avoid any influence on the transmission and on pulse dialling.

The smoothing capacitor should be in the range of 10 to 68 nF. The choke coil must have an inductance of >1mH and a dc resistance of < 15 ohm.

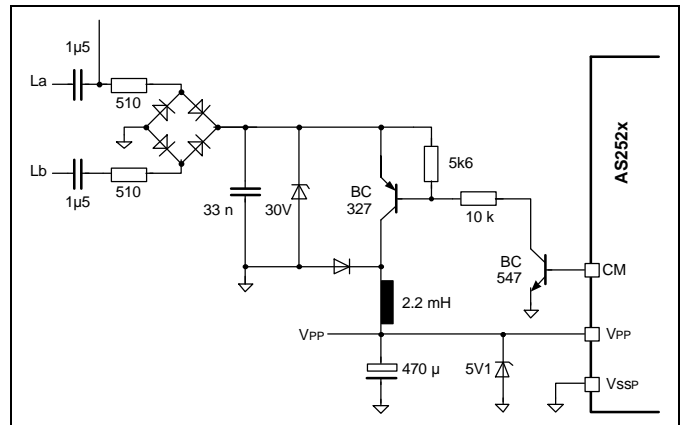

*Figure 7: Switching Converter*

**Tone Input**

The tone input is a digital input in ringing mode and during melody feedback. The digital melody signal (PDM = pulse density modulation) is directly applied to the TI input (see also application notes for further details).

During DTMF dialling the DTMF signal is applied through a capacitor to the TI input and will be fed to the line (pin LI) and to the receive output (RO) as confidence tone.



**Electrical Characteristics****Absolute Maximum Ratings\***

Supply Voltage.....	$-0.3 \leq V_{DD} \leq 7V$
Input Current.....	$\pm 25 \text{ mA}$
Input Voltage (LS).....	$-0.3V \leq V_{IN} \leq 10V$
Input Voltage (LI, CS, SS).....	$-0.3V \leq V_{IN} \leq 8V$
Input Voltage (STB, RI).....	$-2V \leq V_{IN} \leq V_{DD} + 0.3V$
Digital Input Voltage.....	$-0.3V \leq V_{IN} \leq V_{DD} + 0.3V$
Electrostatic Discharge .....	$\pm 1000V$
Storage Temperature Range.....	$-65 \text{ to } +125^\circ\text{C}$
Total Power Dissipation .....	$500\text{mW}$

\*Exceeding these figures may cause permanent damage. Functional operation under these conditions is not permitted.

**Recommended Operating Range**

Symbol	Parameter	Conditions	Min.	Typ.*	Max.	Units
$V_{DD}$	Supply Voltage (internally generated)	Speech mode	3.0	4.1	5.5	V
$V_{PP}$	Supply Voltage (internally regulated)	Speech mode	3.0	4.1	5.5	V
$T_{AMB}$	Ambient Operating Temp. Range		-25		+70	$^\circ\text{C}$

\* Typical figures are at  $25^\circ\text{C}$  and are for design aid only; not guaranteed and not subject to production testing.

**DC Characteristics** ( $I_{LINE} = 15 \text{ mA}$ , recommended operating conditions unless otherwise specified)

Symbol	Parameter	Conditions	Min.	Typ.	Max.	Units
$I_{DD}$	Operating Supply Current	HS = high		5	7	mA
		LE = high		5	7	mA
		HS and LE = high		5	7	$\mu\text{A}$
		PD = high, CM running		300		$\mu\text{A}$
$I_{DDPD}$	Power-Down Current	PD = high		200		$\mu\text{A}$
$I_{DD0}$	Standby Current	All digital inputs = $V_{SS}$		1		$\mu\text{A}$
$V_{LI}$	Line Voltage	$13 \text{ mA} < I_{LINE} < 100 \text{ mA}$	4.2	4.5	4.8	V
$I_{OL}$	Output Current, Sink Pin CS, SS	$V_{OL} = 0.4V$		1.5		mA
$I_{OL}$	Output Current, Sink Pin CM	$V_{OL} = 0.4V$		1.5		mA
$V_{IL}$	Input Low Voltage	$T_{AMB} = 25^\circ\text{C}$	$V_{SS}$		$0.2 V_{DD}$	V
$V_{IH}$	Input High Voltage	$T_{AMB} = 25^\circ\text{C}$	$0.8 V_{DD}$		$V_{DD}$	V

**AC Electrical Characteristics**

$I_{LINE} = 15 \text{ mA}$ ;  $f = 800 \text{ Hz}$ ; recommended operating conditions unless otherwise specified.

Transmit

Symbol	Parameter	Conditions	Min.	Typ.	Max.	Units
$A_{TX}$	Gain (M1/M2 to LS)	HS, LH modes; LLC = $A_{GND}$	35	36.5	38	dB
	Gain (M3/M4 to LS)	HF mode; LLC = $A_{GND}$	45	46.5	48	dB
$A_{MF}$	Gain (TI to LS)	MF mode	12	13.5	15	dB
$\Delta A_{TX/F}$	Variation with Frequency	$f = 500 \text{ Hz to } 3.4 \text{ kHz}$		+/- 0.8		dB
$A_{LLC}$	Gain Range, LLC	Speech mode; LLC = $V_{SS}$ or $V_{DD}$		-6		dB
THD	Distortion	$V_{LI} < 0.25 V_{RMS}$			2	%
$V_{AGC}$	Soft Clip Level	HS, LH modes; $V_{LI} =$		2		$V_{PEAK}$
$V_{AGC}$	Soft Clip Level	HF mode; $V_{LI} =$		650		$mV_{PEAK}$
$A_{SCO}$	Soft Clip Overdrive			30		dB
$Z_{IN}$	Input Impedance;	M1/M2 and M3/M4		15		kohm
$A_{AD}$	Attenuation Depth			30		dB
$A_{MUTE}$	Mute Attenuation	Mute activated	60			dB
$V_{NO}$	Noise Output Voltage	HS = high; $T_{AMB} = 25^{\circ}\text{C}$			-72	dBmp
		LE = high; HS = low; $T_{AMB} = 25^{\circ}\text{C}$			-62	dBmp
$V_{IN MAX}$	Input Voltage Range; M1/M2	Differential		+/- 1		$V_{PEAK}$
		Single ended		+/- 0.5		$V_{PEAK}$

Line Driver

Symbol	Parameter	Test Conditions	Min.	Typ.	Max.	Units
$V_{IN MAX}$	Input Voltage Range; LI			+/- 2		$V_{PEAK}$
RL	Return Loss	$Z_{RL} = 1000 \text{ ohm}$ ; $T_{AMB} = 25^{\circ}\text{C}$	18			dB
$\Delta Z_{AC/TEMP}$	Temperature Variation			0.5		$\Omega/^{\circ}\text{C}$

## Receive

Symbol	Parameter	Condition	Min.	Typ.	Max.	Units
$A_{RX}$	Gain (LS to RO), Default	Volume reset	1.5	3	4.5	dB
	LSP Gain (LSI to LO)		17.5	19	20.5	dB
$\Delta A_{TX/F}$	Variation with Frequency	f = 500 Hz to 3.4 kHz		+/- 0.8		dB
$A_{LLC}$	Gain Range, LLC	Speech mode; LLC = $V_{SS}$ or $V_{DD}$		-6		dB
$A_{RX}$	Volume Range	10 steps, each 2 dB		20		dB
THD	Distortion	$V_{RI} < 0.2 V_{RMS}$			2	%
$V_{SC}$	Soft Clip Level (RO)	$V_{RO} =$		1		$V_{PEAK}$
	Soft Clip Level (LO)	Not AS2520B/21B; $V_{LO} =$ Unloaded		1.3		$V_{PEAK}$
$A_{SCO}$	Soft Clip Overdrive			30		dB
$V_{RTH}$	Threshold Voltage at RTH		7	15	25	mV
$A_{AD}$	Attenuation Depth			30		dB
$t_{DECAY}$	Attack Time	Channel control; $V_{RI} > 0.8 V_{RMS}$				$\mu s/6dB$
$t_{DECAY}$	Decay Time	Channel control				$\mu s/6dB$
$V_{NO}$	Noise Output Voltage (RO)	HS = high; $T_{AMB} = 25^{\circ}C$			-72	dBmp
$V_{UFC}$	Unwanted Frequency Components (RO)	50 Hz.....20 kHz			-60	dBmp
$Z_{IN}$	Input Impedance, RI			8		kohm
$V_{INRI}$	Input Voltage Range, RI			+/- 2		$V_{PEAK}$
$A_{ST}$	Sidetone Cancellation	$V_{RI} < 0.2 V_{RMS}$ ; $T_{AMB} = 25^{\circ}C$	26			dB
$Z_{IN}$	Input Impedance, STB			80		kohm
$V_{INST}$	Input Voltage Range, STB			+/- 2		$V_{PEAK}$

## General Timings

Symbol	Parameter	Condition	Min.	Typ.	Max.	Units
$t_{VOL}$	Volume Key Debounce			7		ms
$t_{SCA}$	Soft Clip Attack Time	$V_{IN}$ above soft clip level		0.12		ms/6dB
$t_{SCD}$	Soft Clip Decay Time	$V_{IN}$ below soft clip level		128		ms/6dB
$t_{PDA}$	Peak Detector Attack Time	$V_{IN}$ above $V_{TH}$		3.2		ms/V
$t_{PDD}$	Peak Detector Decay Time	$V_{IN}$ below $V_{TH}$		29		ms/V
$t_{LPA}$	Low-Power Attack Time	$V_{PP} < 3.6V$		250		ms/6dB
$t_{LPD}$	Low-Power Release	$V_{PP} > 3.6V$		1		sec/6dB

Test Circuit

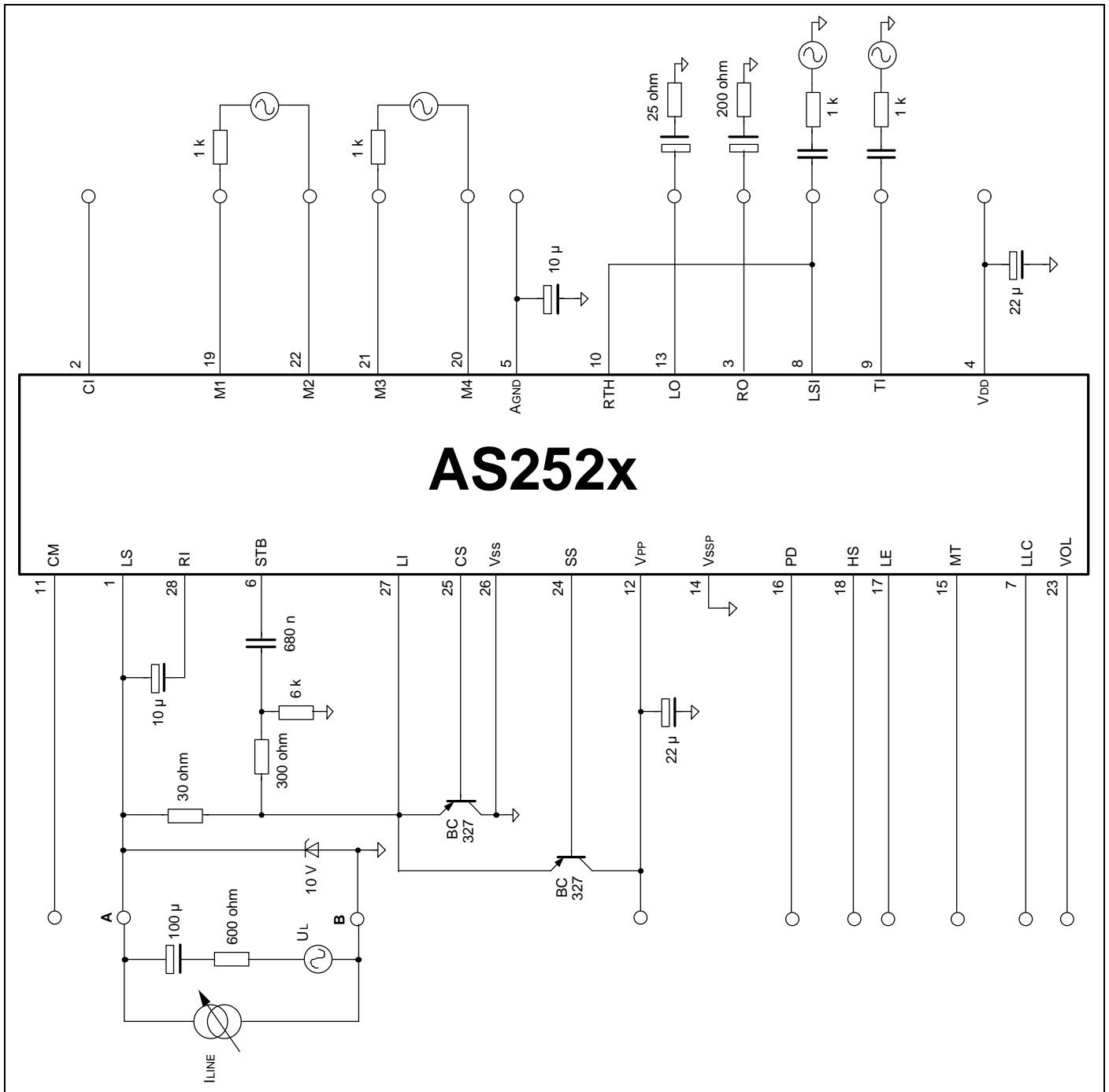

Figure 8: Test Circuit

Application Diagramme

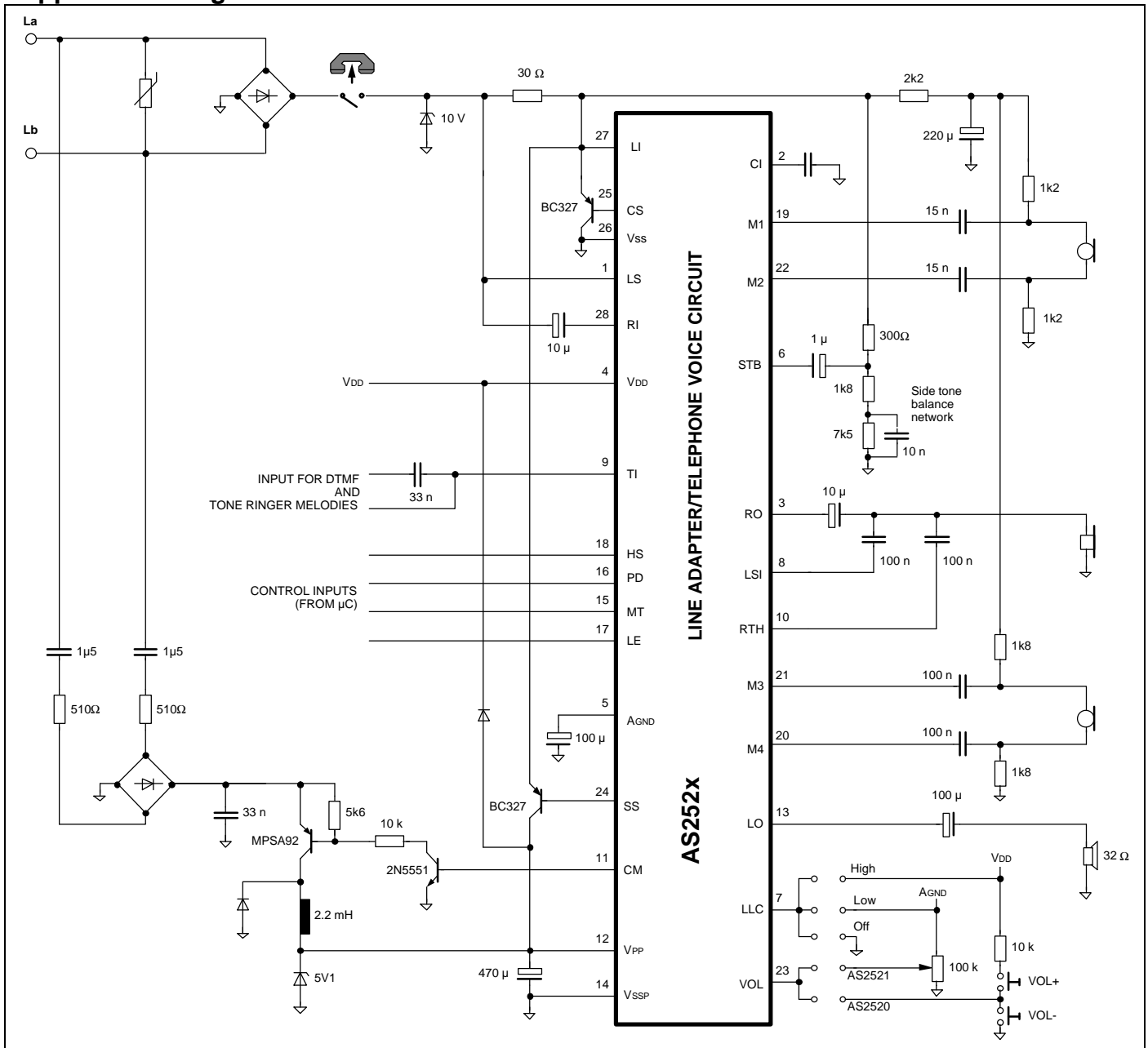

Figure 9: Application Diagramme

Applications Hints

Interface to Microcontroller

In off-hook condition the microcontroller can be supplied from  $V_{DD}$  of AS252x. The digital inputs (HS, LE, PD, and MT) must be kept low until  $V_{DD}$  has reached its minimum operating voltage ( $>2.5V$ ).

Radio Frequency Interference

The RFI sensitivity has been minimised by the consequent use of CMOS technology and one overall ground and by having differential inputs with a relative low input impedance.

For further application information see application notes for the AS2520 series.

## Pin Configuration

### 28 Pin SOP/DIP

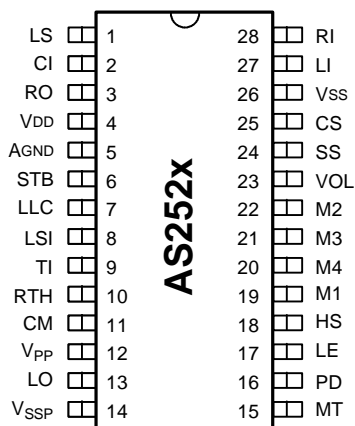

## Ordering Information

Part Number	Package Type	Volume Control	Soft Clip Loudspk.
AS2520 T	28 pin SOP	Digital	Yes
AS2520 P	28 pin DIP	Digital	Yes
AS2520B T	28 pin SOP	Digital	No
AS2520B P	28 pin DIP	Digital	No
AS2521 T	28 pin SOP	Analogue	Yes
AS2521 P	28 pin DIP	Analogue	Yes
AS2521B T	28 pin SOP	Analogue	No
AS2521B P	28 pin DIP	Analogue	No

The devices are also available as dice on request.

Devices sold by Austria Mikro Systeme Int. AG are covered by the warranty and patent indemnification provisions appearing in its Term of Sale. Austria Mikro Systeme Int. AG makes no warranty, express, statutory, implied, or by description regarding the information set forth herein or regarding the freedom of the described devices from patent infringement. Austria Mikro Systeme Int. AG reserves the right to change specifications and prices at any time and without notice. Therefore, prior to designing this product into a system, it is necessary to check with Austria Mikro Systeme Int. AG for current information. This product is intended for use in normal commercial applications. Applications requiring extended temperature range, unusual environmental requirements, or high reliability applications, such as military, medical life-support or life-sustaining equipment are specifically *not* recommended without additional processing by Austria Mikro Systeme Int. AG for each application.

Copyright © 1999, Austria Mikro Systeme International AG, Schloss Premstätten, 8141 Unterpremstätten, Austria. Trademarks Registered®. All rights reserved. The material herein may not be reproduced, adapted, merged, translated, stored, or used without the prior written consent of the copyright owner.

Austria Mikro Systeme Int. AG reserves the right to change or discontinue this product without notice.