

Features

- 0.8V Low Start-Up Input Voltage
- Up to 90%Efficiency
- Adjustable 100mA Output with 1 Alkaline Cell or 200mA Output with 2 Alkaline Cell Battery input.
- 1.8V/3.0V/3.3V/300mA Output with USB Power input.
- Small Number of External Components needed
- Load Disconnects from Input in Shutdown
- Power good output
- 32 μ A Quiescent(Switch OFF) Supply current
- 1 μ A Shutdown Mode Supply current
- 8-Pin TSSOP package

Applications

- MP3
- Power source for battery-powered equipment
- Power source for cameras, camcorders, VCRs, PDAs, electronic data banks, and hand-held Communication equipment

General Description

The AT1305 is a PFM step-up DC/DC converter with LDO for applications using 1 Cell or 2 Cell Alkaline battery and USB applications. Besides, the 32 μ A low quiescent current together with high efficiency maintains long battery life time. It provides a constant output voltage for inputs that vary above and below the output voltage.

Block Diagram

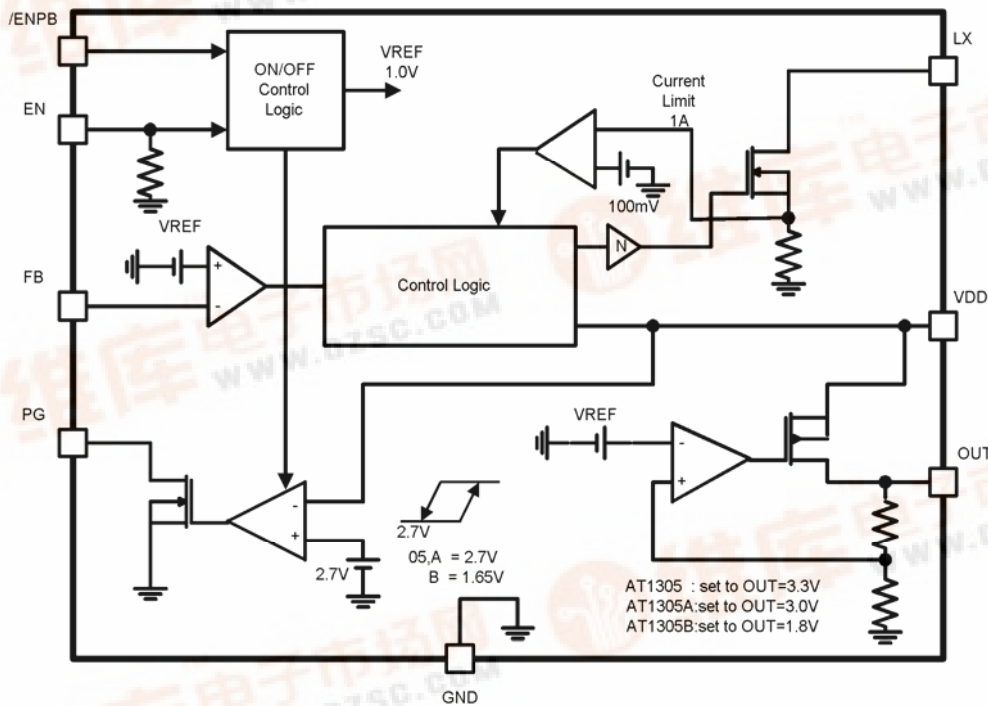

Aimtron reserves the right without notice to change this circuitry and specifications.



Pin Configuration

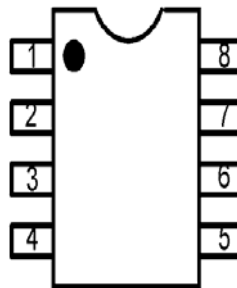

Ordering Information

Part number	Package	Remarks
AT1305	8-pin Plastic TSSOP	□□□□□□ Date Code
AT1305_GRE	8-pin Plastic TSSOP, Green	□□□□□□,Date Code with one bottom line
AT1305 A	8-pin Plastic TSSOP	□□□□□□ Date Code
AT1305 A_GRE	8-pin Plastic TSSOP, Green	□□□□□□,Date Code with one bottom line
AT1305 B	8-pin Plastic TSSOP	□□□□□□ Date Code
AT1305 B_GRE	8-pin Plastic TSSOP, Green	□□□□□□,Date Code with one bottom line

AT1305:LDO set to 3.3V AT1305AP:LDO set to 3.0V AT1305BP:LDO set to 1.8V

**For more marking information, contact our sales representative directly*

Pin Description

Pin No.	Symbol	I/O	Description
1	LX	O	Switching Output
2	EN	I	Enable Control Input, active high
3	/ENPB	I	Enable Control Input, active low
4	GND	-	Ground
5	PG	O	Power Good Detected
6	FB	I	Step-Up Converter feedback input
7	OUT	O	Output
8	VDD	-	Power input

Absolute Maximum Ratings*1

(T_a=+25°C)

Parameter	Symbol	Condition	Rated Value		Unit
			Min.	Max.	
Power supply voltage	V _{DD}	—	—	6.0	V
LX pin voltage	V _{LX}	—	—	6.0	V
OUT output voltage	V _{OUT}	—	—	6.0	V
Other I/O pin voltage		—	—	6.0	V
LX pin output current	I _{LX}	—	—	2	A
LDO output Peak Current	I _{LDO}	—	—	400	mA
Allowable dissipation	P _D	TSSOP8	—	500	mW
Operating temperature	T _{OP}	—	-30	+85	°C
Storage temperature	T _{stg}	—	-55	+165	°C

1. Stresses beyond those listed under “Absolute Maximum Ratings” may cause permanent damage to the device. These are stress ratings only, and functional operation of the device at these or any other conditions beyond those indicated in the operational sections of the specifications is not implied. Exposure to absolute maximum rating conditions for extended periods may affect device reliability.

Electrical Characteristics

(V_{IN}=1.0V, V_{OUT}=2.8V, I_{OUT}=0mA, T_a=+25°C)

Parameter	Symbol	Condition	Values			Unit
			Min.	Typ.	Max.	
Start-Up Voltage	V _{ST}	I _{OUT} =1mA	0.7	0.8	-	V
Power On Reset Threshold	V _{DD}		-	2	-	V
Operating V _{DD} Range	V _{DD}	AT1305,AT1305A	2.0	-	5.5	V
		AT1305B	1.65		5.5	V
No-Load Input Current	I _{IN1}	I _{OUT} =0mA	-	87	-	μA
Switch- Off Input Current	I _{IN2}	V _{IN} =5V	-	32	50	μA
Shutdown Current	I _{IN3}	EN=0V, /ENPB=High	-	1	10	μA
Feedback Reference	V _{FB}	Close Loop V _{DD} =2.85V	1.176	1.2	1.224	V
FB Input Current	I _{FB}	V _{FB} =1.2V	-	-	50	nA
LX Switch On-time	F _S	V _{OUT} =2.85V	-	1.75	-	μS

Maximum Duty	D_{MAX}	$V_{OUT} = 2.85V$	-	85	-	%
LX ON Resistance	R_{LX}	N-Channel	-	0.3	-	Ω
LX Leakage Current	I_L	$V_{LX} = 1.5V,$ $EN = 0V, ENPB = VDD$	-		1	μA
Current Limit Setting	I_{LX}	$V_{DD} = 2.85V$	-	1.5	2	A
LDO Current Limit	I_{LDO}	$V_{DD} = 3.2V$	-	350	-	mA
OUT ON Resistance	R_{OUT}	$V_{DD} = 2.85V, I_{OUT} = 100mA$	-	0.5	-	Ω
LDO enable threshold	V_{DD1}	OUT regulated to 1.8/3.0/3.3V	-	4.0	-	V
LDO Line Regulation		$V_{in} = 4.5V \sim 5.5V,$ $I_{OUT} = 100mA$	-	1	-	%
LDO Load Regulation		$V_{out} = 3.3V, I_{OUT} = 10 \sim 100mA$	-	1	-	%
PG Threshold	V_{DD2}	AT1305, AT1305A, VDD falling	-	2.7	-	V
		AT1305B, VDD falling	-	1.65	-	V
PG sink current	I_{PG}	$I_{PG} = 1mA$	-	0.4	-	V
PG Leakage current	I_{LPG}	$V_{DD} = 3V$	-	-	1	μA
EN, /ENPB Trip Level	V_{IH}		0.8	-	-	V
	V_{IL}		-	-	0.5	V

Note 1 : Once the output is in regulation , the AT1305/A/B operate down to a 0.7V input voltage.

Typical Operating Characteristics

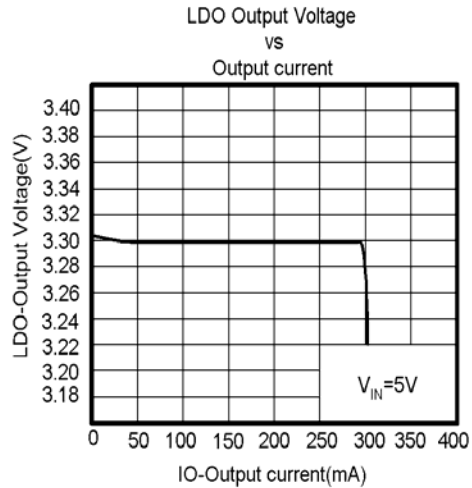
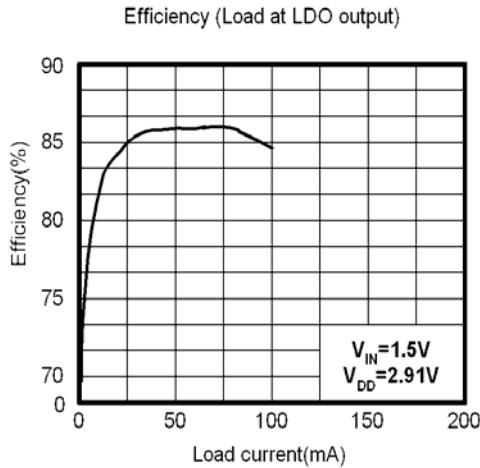

Boost Converter Line Transient Response

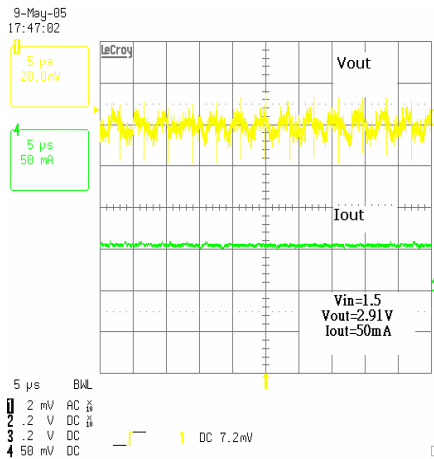

Boost Converter Line Transient Response

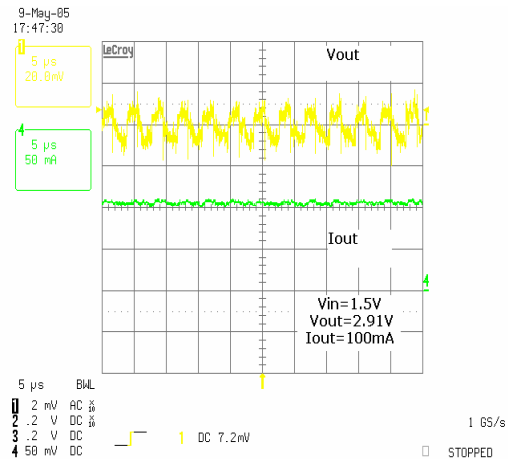

Boost Converter Load Transient Response

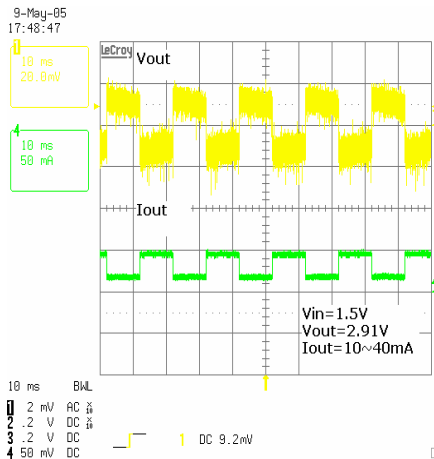

Boost Converter Load Transient Response

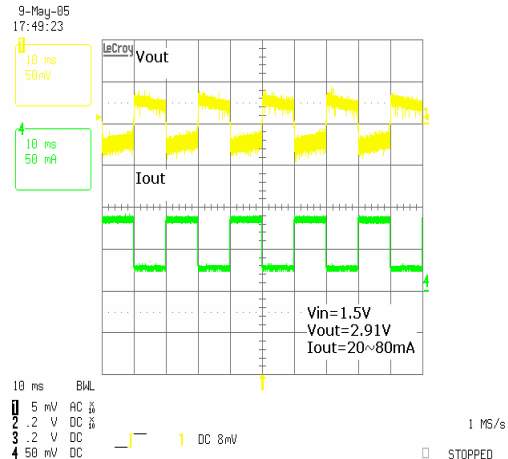

LDO Line Transient Response

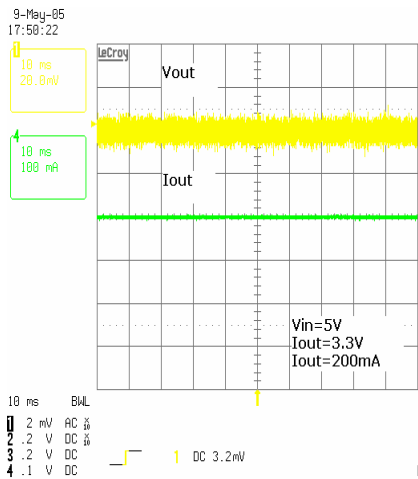

LDO Load Transient Response

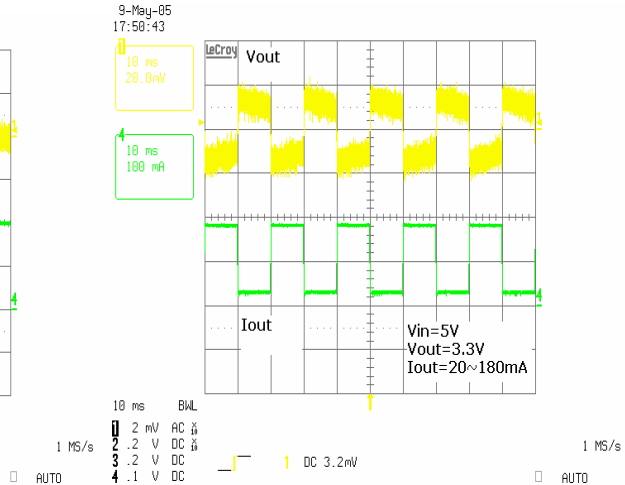

Boost Converter Start-up After Enable

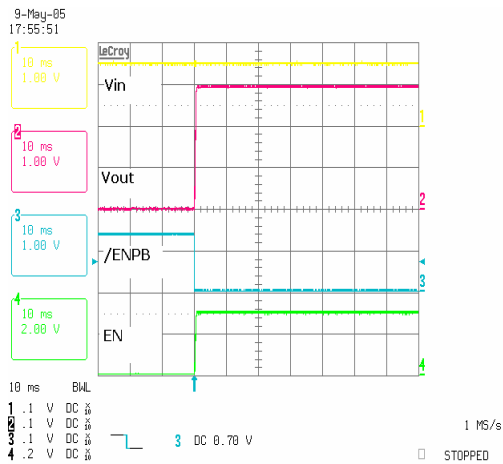

Typical Application Circuit

1Cell And USB Power Input

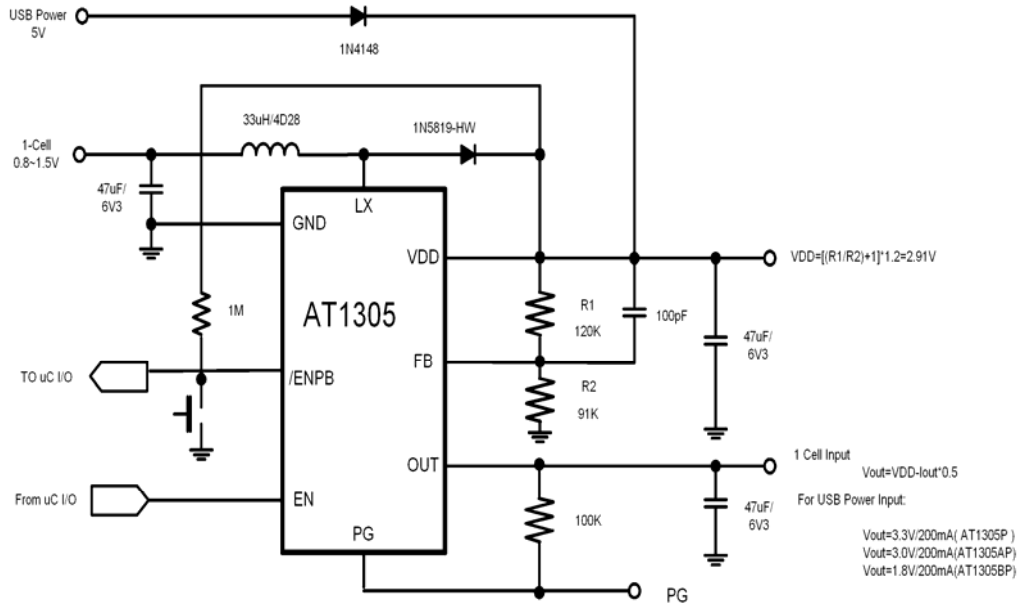

1Cell or USB Power Input

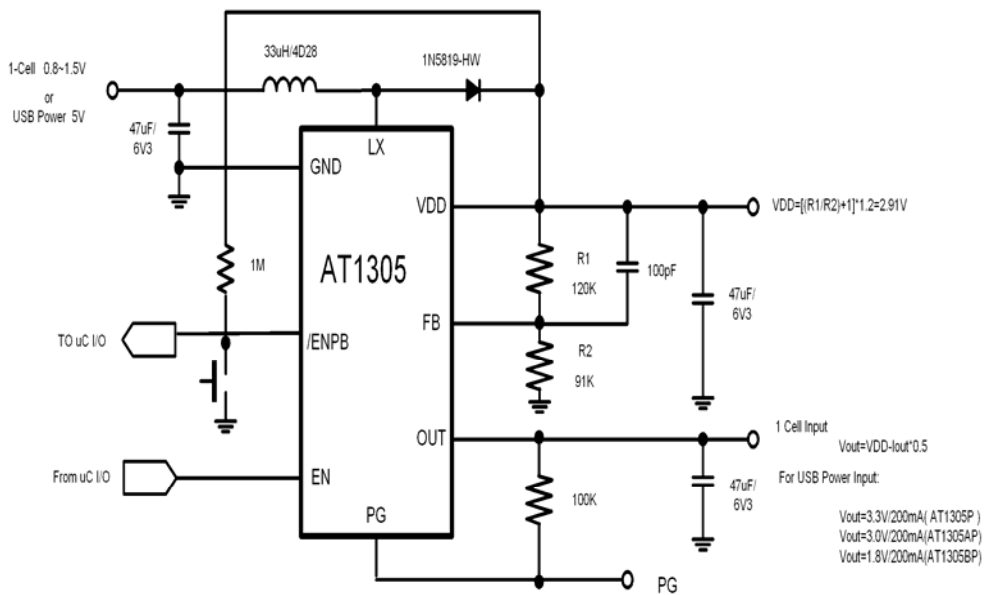

Typical Operating Characteristics

1Cell and USB Power Input

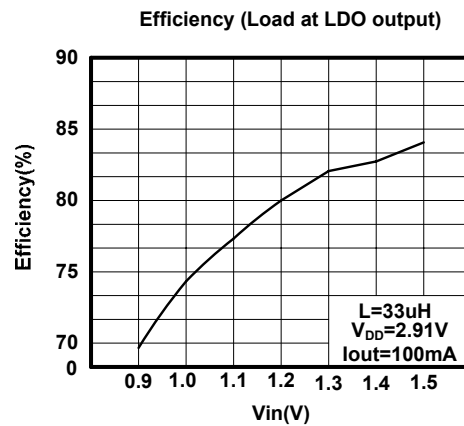
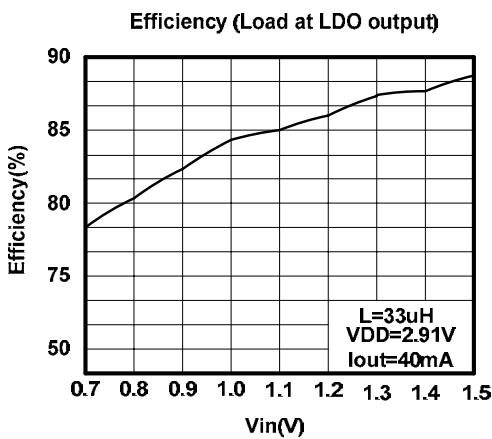
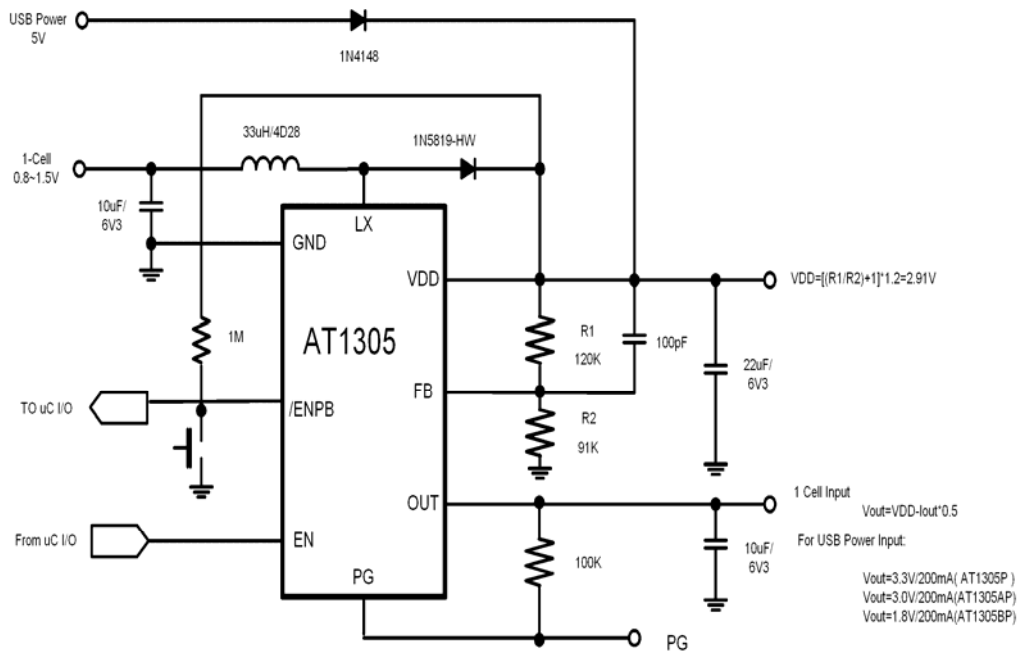

2Cell And USB Power Input

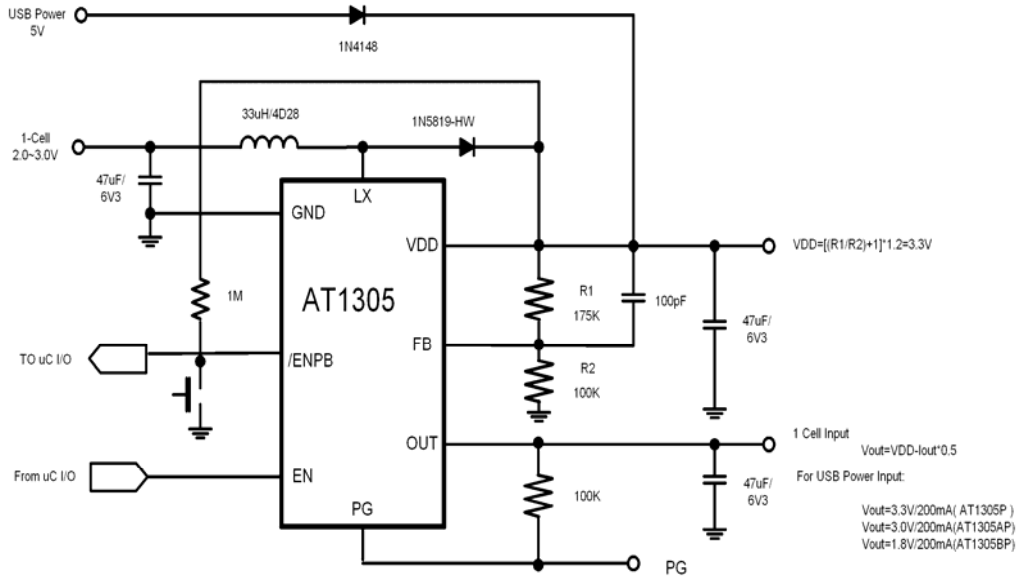

Efficiency (Load at LDO output)

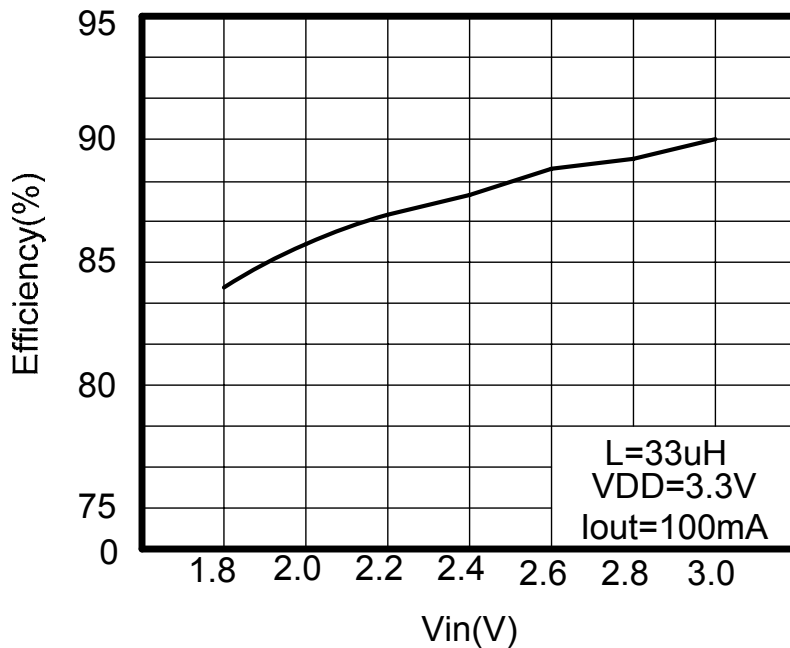

Function Description

Boost Converter

The AT1305 integrates a step-up, switch-mode DC/DC converter with a linear regulator to provide step up/down voltage conversion. A pulse frequency modulation (PFM) with a constant on time 4.5us and minimum off-time 1.4μs controls the N-channel MOSFET. The linear regulator contains a P-channel MOSFET. In 1-cell or 2-cell battery input (When VBAT < VOUT), only the step-up regulator is active, and the linear regulator behaves as a pass gate. The output voltage can be adjusted with two external resistors. The formula show as follow equation.

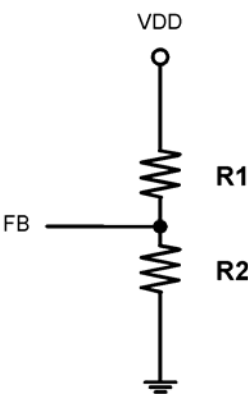
$$\begin{aligned}
 VDD &= V_{FB} \left(1 + \frac{R1}{R2} \right) \\
 &= 1.2 \times \left(1 + \frac{R1}{R2} \right)
 \end{aligned}$$

The maximum efficiency could be 89% over 50mA load range. The AT1305 guarantee starts up as low as 1.0V input.

LDO mode

The low-dropout linear regulator consists of a reference, an error amplifier and a P-channel MOSFET. In USB mode, when VIN > 4V, the linear regulator is active automatically whether the EN and /ENPB is enabled or not. The output voltage is default 3.3V, 3.0V and 1.8V version. Its driving capability is nearly 250mA.

Power good

The PG pin stays high impedance when the dc/dc converter or the LDO output voltage high than 2.7 V, and falling down when the voltage low than 2.6V. It could be used to enable the processor after the push-button start-up.

On/Off Control

A single pushbutton switch can be used to turn the AT1305 on and off. EN is pulled low (internal) and /ENPB is pulled high when the AT1305 is off. When the switch is pressed, /ENPB is pulled low and the IC turns on. The switch should be on long enough for the processor to exit reset. The controller issues a logic high to EN, which guarantees the IC will stay on regardless of the switch state.

EN	/ENPB	AT1305
0	0	ON
0	1	OFF
1	0	ON
1	1	ON

Package Outline : 8-pin TSSOP

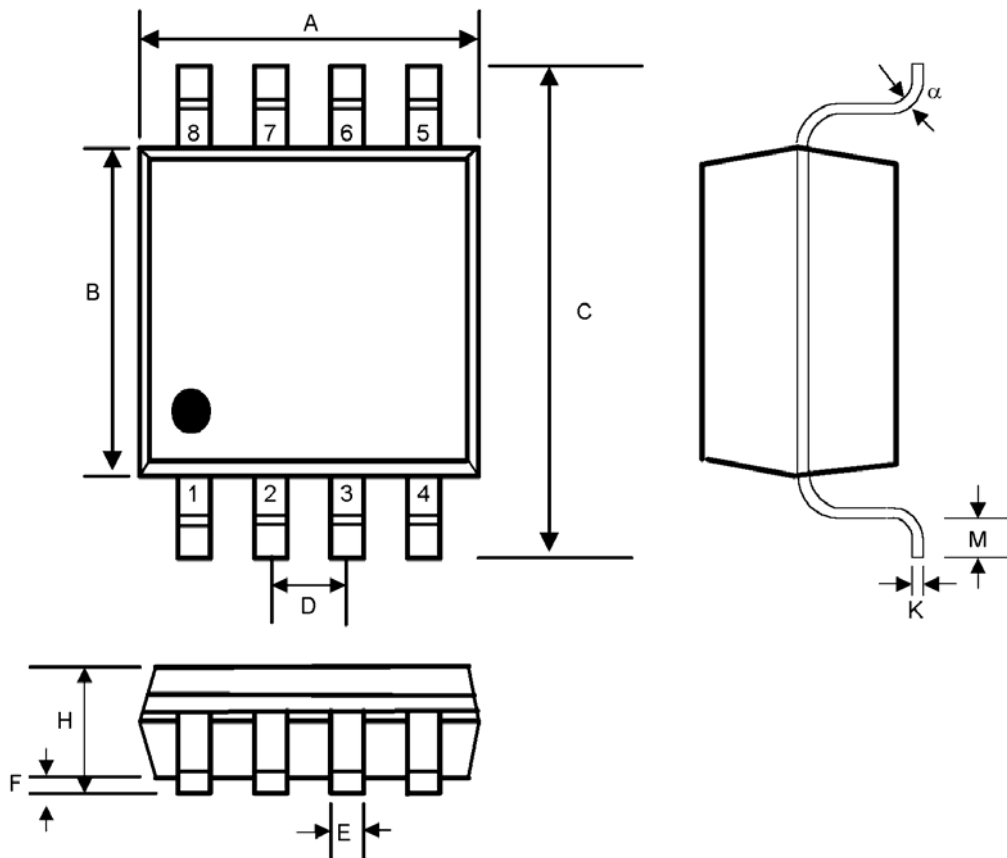

SYMBOL	INCHES		MILLIMETERS		NOTES
	MIN	MAX	MIN	MAX	
A	0.114	0.122	2.90	3.10	-
B	0.169	0.177	4.30	4.50	-
C	0.244	0.260	6.20	6.60	-
D	0.026	BSC	0.65	BSC	-
E	0.010	0.012	0.25	0.30	-
F	0.002	0.006	0.05	0.15	-
H	0.041	0.047	1.05	1.20	-
K	0.005	BSC	0.127	BSC	-
M	0.020	0.028	0.50	0.70	-
α	0°	8°	0°	8°	-

Reflow Profiles

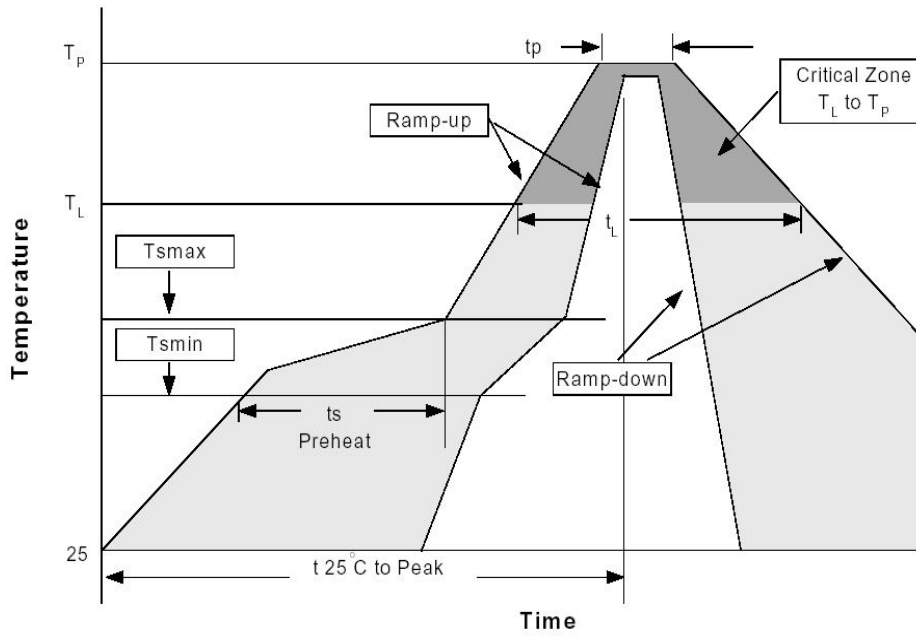

Profile Feature	Sn-Pb Eutectic Assembly		Pb-Free Assembly	
	Large Body Pkg. thickness $\geq 2.5\text{mm}$ or Pkg. volume $\geq 350\text{mm}^3$	Small Body Pkg. thickness $< 2.5\text{mm}$ or Pkg. volume $< 350\text{mm}^3$	Large Body Pkg. thickness $\geq 2.5\text{mm}$ or Pkg. volume $\geq 350\text{mm}^3$	Small Body Pkg. thickness $\geq 2.5\text{mm}$ or Pkg. volume $\geq 350\text{mm}^3$
Average ramp-up rate (T_L to T_P)	3°C/second max.		3°C/second max.	
Preheat -Temperature Min(T_{min}) -Temperature Max (T_{max}) -Time (min to max)(t_s)	100°C 150°C 60-120 seconds		150°C 200°C 60-180 seconds	
T_{max} to T_L -Ramp-up Rate			3°C/second max.	
Time maintained above: -Temperature (T_L) -Time (t_L)	183°C 60-150 seconds		217°C 60-150 seconds	
Peak Temperature(T_P)	225+0/-5°C	240+0/-5°C	245+0/-5°C	250+0/-5°C
Time within 5°C of actual Peak Temperature (t_p)	10-30 seconds	10-30 seconds	10-30 seconds	20-40 seconds
Ramp-down Rate	6°C/second max.		3°C/second max.	
Time 25°C to Peak Temperature	6 minutes max.		8 minutes max.	

*All temperatures refer to topside of the package, measured on the package body surface.