



圓創科技股份有限公司

AT1313

High Efficiency, Constant Current
White-LED Driver

Feature

- Operating Voltage: 2.5V~5.5V
- High Operating Frequency: 1.4MHz
- High Output Voltage: Up to 18V
- Shutdown Current <math>< 1\mu A</math>
- 18V Output Over-voltage protection
- Digital Dimming Control.
- Built-in Cycle-by Cycle Current-limiting.
- Built-in Soft-Start Function.
- 0.2V Low Reference Voltage
- Tiny SOT-26 Package

Application

- LED Module
- Compact Back Light Module
- Constant Current Source

Description

The AT1313 step-up converter drives white LEDs with a constant current to provide backlight in cell phones, PDAs, and other hand-held devices. It features allowing series connection of the white LEDs so that the LED currents are identical for uniform brightness. An enable input can be pulsed repeatedly to adjust LED's brightness. The fast 1.4 MHz current-mode PWM control allows for smaller capacitor and inductor. Fault condition protection uses cycle-by-cycle current limiting to sense maximum inductor current, thermal protection and over-voltage protection. Also included soft-start eliminates inrush current during start-up. The 0.2V low reference voltage minimized the power loss across the current-setting resistor.

The AT1313 is available in 6-pin SOT-26 packages.

Block Diagram

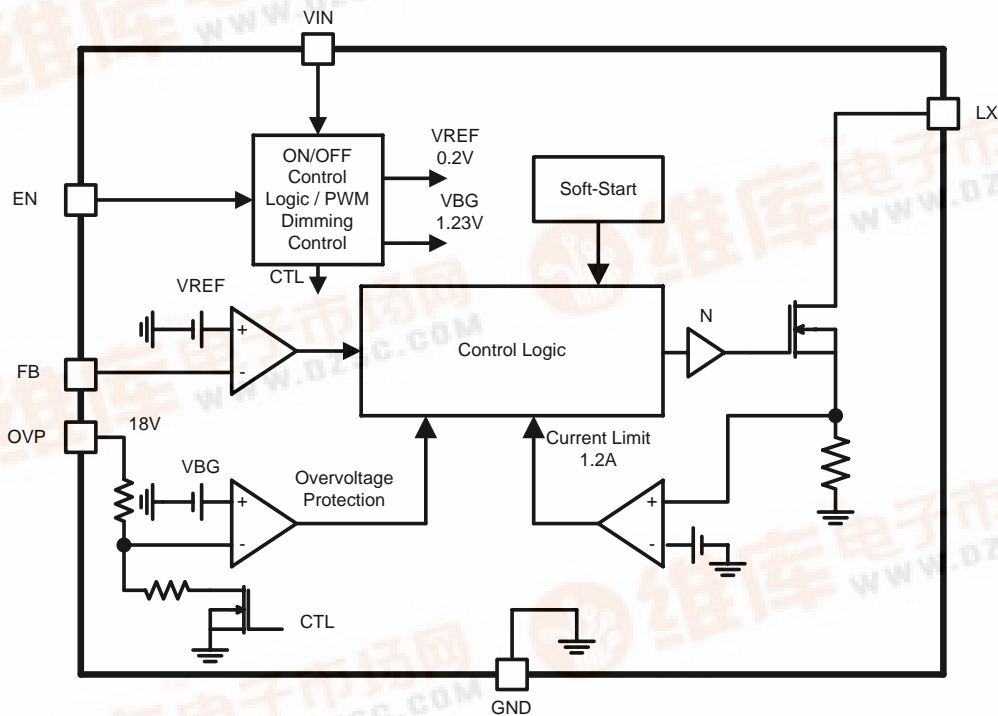

Aimtron reserves the right without notice to change this circuitry and specifications.



Pin Configuration

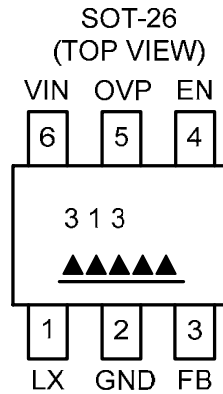

Ordering Information

Part number	Package	Marking
AT1313X_GRE	SOT-26, Green	313, Date Code with one bottom line

: Date Code

**For more marking information, contact our sales representative directly*

Pin Description

Pin NO.	Symbol	I / O	Description
1	LX	I	Step-up Regulator N-MOS Drain. Place output diode and inductor.
2	GND	P	Ground
3	FB	I	Step-Up Regulator Feedback Input. Connect a sense resistor from FB to ground.
4	EN	I	Enable and Dimming Control Input. LED brightness and IC shutdown are controlled by the voltage on EN. Driving low for longer than 4ms to shutdown the IC.
5	OVP	I	Over-voltage protection input. Connect to the output.
6	VIN	P	Power supply.

Absolute Maximum Ratings[[note1](#)]

Parameter	Rated Value	Unit
VIN voltage	-0.3 to +6.0	V
LX , OVP voltage	-0.3 to +18	V
EN , FB to GND	-0.3 to +6.0	V
Switch Current (I_{LX})	1.2	A
Continuous power dissipation (SOT-26 $T_a=+25^{\circ}C$)	0.35	W
Operating Junction Temperature Range	-35 to 85	$^{\circ}C$
Lead Temperature (Soldering 5 sec)	260	$^{\circ}C$
Storage Temperature	-65 to 125	$^{\circ}C$
Package Thermal Resistance (Θ_{JA})	250	$^{\circ}C/W$
ESD Susceptibility (HBM)	2	KV
ESD Susceptibility (MM)	200	V

Note1:Permanent device damage may occur if Absolute Maximum Ratings are exceeded. Exposure to absolute maximum rating conditions for extended periods may affect device reliability



Recommended Operation Conditions

Parameter	Symbol	Values			Unit
		Min.	Typ.	Max.	
Power supply voltage	V _{IN}	2.5	—	5.5	V
Operating temperature	Top	-30	+25	+85	°C

Electrical Characteristics

(V_{IN}=2.5V, Ta=+25°C, unless otherwise noted)

Parameter	Symbol	Test Condition	Min.	Typ.	Max.	Units
Operating V _{IN} Range	V _{IN}	V _{IN} input Voltage	2.5	-	5.5	V
Under Voltage Thershold	UVLO	V _{IN} falling, 100mV hysteresis	2.1	2.2	2.3	V
Switch- Off Input Current	I _{IN1}	No Switching , FB>0.2V	-	100	120	uA
Shutdown Current	I _{IN3}	EN=0V	-	-	1	uA
Feedback Reference	V _{FB}		0.190	0.2	0.210	V
FB Input Bias Current	I _{FB}	V _{FB} =0.2V	-	-	1	uA
Over-voltage Threshold	V _{OVP}	V _{OUT} Rising	16	18	20	V
Over-voltage Hysteresis				2		V
OVP Leakage Current	I _{OVP}	EN=0V	-	-	1	uA
Output Voltage Line Regulation		2.5V < V _{IN} < 6.0V	-	0.1	-	%
Switching Frequency	f _{OSC}		1.2	1.4	1.6	MHz
Maximum Duty	D _{MAX}		-	90	-	%
Soft-Start charging time	t _{SS}		0.05	0.5		ms
Switching Current Limit	I _{LX}	V _{IN} =3.0V,duty cycle=80% ,	-	1.2	-	A
LX ON Resistance	R _{LX}	V _{IN} =2.5V, I _{LX} =800mA	-	0.4	-	Ω
LX Leakage Current	I _{Leakage}	V _{LX} =16V, EN=0V	-	-	1	uA
EN Input Current	I _{EN}	EN=5V	-	-	1	uA
EN Input Level	V _{IH}		2.0	-	-	V
	V _{IL}		-	-	0.5	V
EN low Shutdown Delay				4		ms
EN Low Cycle Time	t _{CYCL}	Note(1)	0.05		5	ms
EN High Cycle Time	t _{CYCH}	Note(1)	0.05		5	ms

Note(1): t_{CYCL} and t_{CYCH} are included rising time and falling time of PWM signal.



圓創科技股份有限公司

AT1313

**High Efficiency, Constant Current
White-LED Driver**

Typical Characteristics

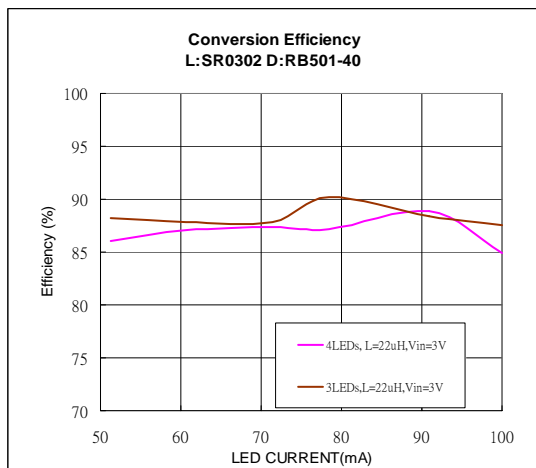
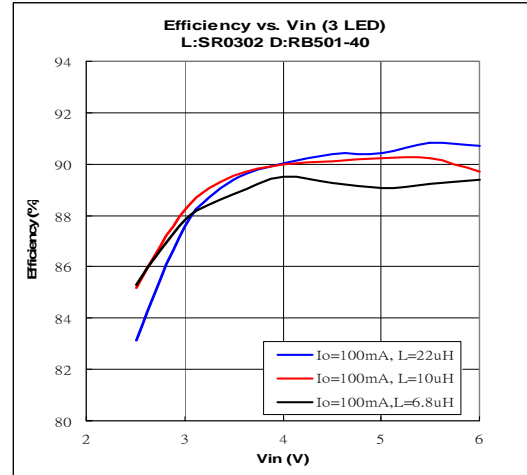
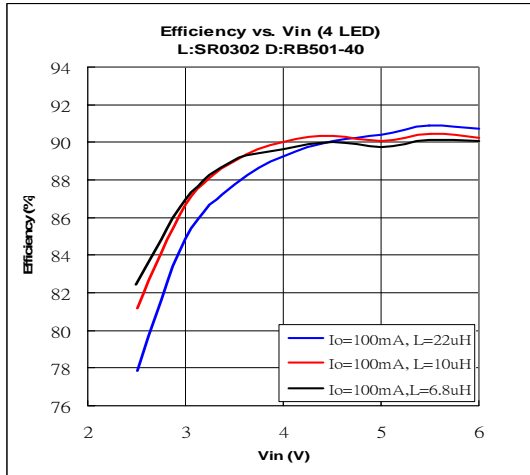

CH1:LX CH3:V_{OUT} Ripple CH4:I_{LX}

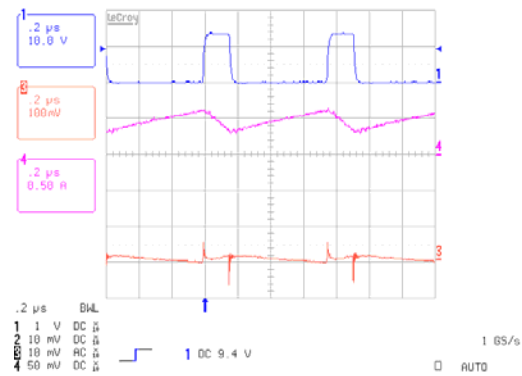

Switching Transient Waveform

CH1:EN CH3:FB

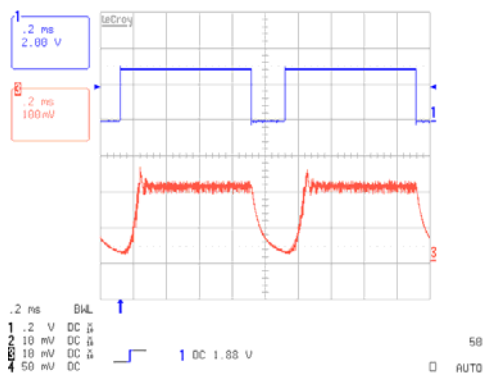

PWM Dimming Control Using the EN Pin

CH1:EN CH3:FB CH4:I_{IN}

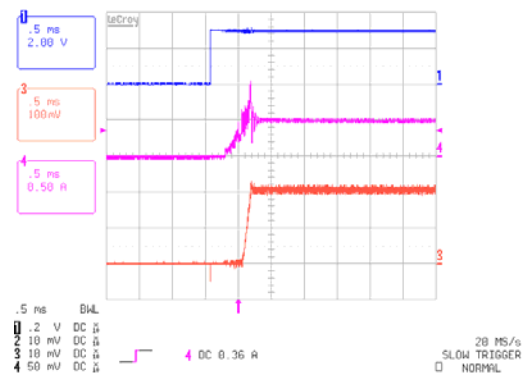

Start-Up Waveform

Application Circuit

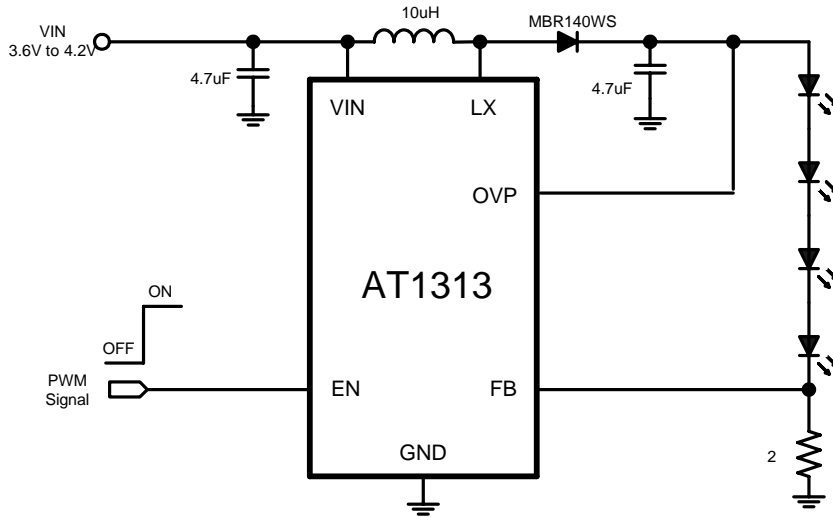

Figure 1a. AT1313 Typical Application Circuit with 100mA Output .

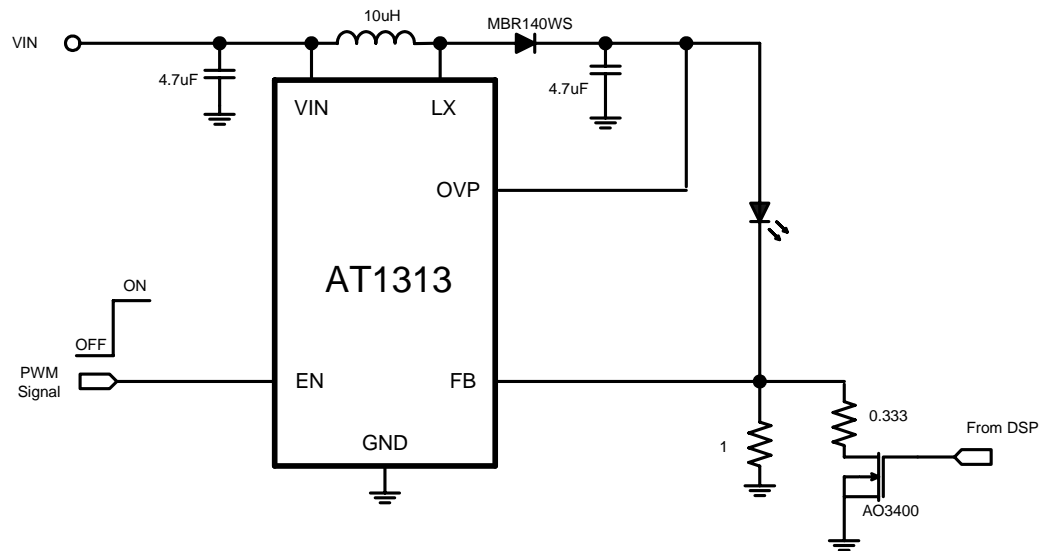

Figure 1b. AT1313 Typical Application Circuit with 200mA Output .

Application Circuit

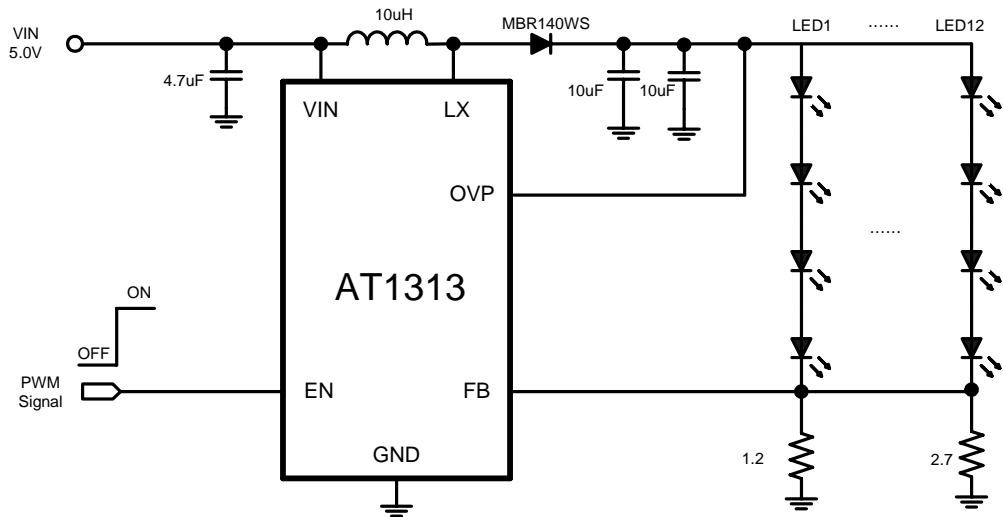

Figure 1c. AT1313 for Innolux 8" Panel LED Back light unit .

Function Description

The AT1313 is a high efficiency and constant current DC-DC converter IC which is designed primarily for use in LED module applications. The output voltage of the step-up converter can be set from V_{in} to 16V with external sense resistor. The device suits to drive series-connected LEDs and provides even illumination by sourcing the same output current through each LED. AT1313 also consists of a logic shutdown , cycle-by-cycle current-limited , soft-start functions.

Logic control input or PWM duty cycle control allows easy adjustment of LEDs brightness and on/off control. The average LED current is proportionable the duty-cycle of the PWM signal. Typical PWM frequency should be between 100Hz and 1kHz.

The boost converter operates in current-mode PWM and a constant frequency of 1.4 MHz. Depending on duty cycle of each switching cycle can regulate output voltage. On the rising edge of the internal clock , the control and driver logic block sets internal flip-flop when the output voltage is too low, which turns on the N-MOS. The external inductor current ramps up linearly, storing energy in a magnetic filed. Once peak current of inductor over trans-conductance output level , the N-MOS turns off, the flip-flop resets, and external schottky diode turns on. This forces the current through the inductor to ramp back down, transferring the energy stored in the magnetic field to the output capacitor and LEDs. To reduce external component amount , the device will be built-in internal loop compensation.

Enable Control

Digital logic of EN provides an electrical ON/OFF control of the power supply. Connecting this pin to ground or to any voltage less than 0.5V and sustain the level over 4ms will completely turn off the regulator. In this state, current drain from the input supply is less than 1uA, the internal reference, error amplifier, comparators, and biasing circuitry turn off . If holding time of low level is less than 3ms on this pin, then the device only shutdown driver logic block.

Dimming Control

Digital logic of EN also provides LEDs brightness control by applying a PWM signal on EN pin. With this way, the LEDs operate with either zero or full current . The average LED current is proportional to the duty-cycle of the PWM signal. Typical PWM frequency should be between 100Hz and 1kHz. Output current is given by:

$$I_{LED} = \frac{200mV \times T_{ON-PWM}}{R_{SENSE} \times T_{S-PWM}}$$

Where:

T_{ON-PWM} : On time of PWM signal

T_{S-PWM} : A cycle time of PWM signal

If dimming control is not required , EN works as a simple on/off control. Drive EN high to enable the device , or drive EN low for shutdown.

Soft-Start

Soft-start allows a gradual increase of the internal current-limit level for the step-up converter during power-up to reduce input surge currents. As the internal current source charges the internal soft-start capacitor, the peak N-MOS current is limited by the voltage on the capacitor. In another story, when toggle or a logic-level transition on EN pin from low to high, soft-start function must work to enable constant current charging internal capacitor. When soft-start process has finished or appeared falling edge of PWM signal on EN pin, soft-start capacitor must be discharged to ground level.

Cycle-by-Cycle Over-Current Protection

The AT1313 provides cycle-by-cycle over-current protection. Current limit is accomplished using a separate dedicated comparator. The cycle-by-cycle current limit abbreviates the on-time of the N-MOS in event that the current of flowing N-MOS is greater than the current limit value. The current-limit feature protection against a hard short or over-current fault at the output.

Over-Voltage Protection

If V_{OUT} is above 16V or LEDs are disconnected from the circuit, the FB pin is similar to pull down to ground with a sense resistor. This will cause N-MOS to switch with a maximum duty cycle and come out output over-voltage. This may cause the LX pin voltage to exceed its maximum voltage rating to damage built-in N-MOS. In the state, the OVLO protection circuitry stops the internal N-MOS. When V_{OUT} falls below 16V, IC will automatically recover normal operation.

Power dissipation consideration

The AT1312 maximum power dissipation depends on the thermal resistance of the IC package and circuit board, the temperature difference between the die junction and ambient air, and the rate of any airflow. The power dissipation in the device depends on the operating conditions of the regulator.

The step-up converter dissipates power across the internal N-MOS as the controller ramps up the inductor current. In continuous condition, the power dissipated internally can be approximated by :

$$P_{boost} = \left[\left(\frac{I_O \times V_O}{V_{in}} \right)^2 + \frac{1}{12} \left(\frac{V_{in} \times D}{f_{OSC} \times L} \right)^2 \right] \times R_{DS(ON)} \times D$$

where

I_O : It is the load current.

f_{OSC} : It is a switching frequency.

Applications Information

External components of main boost converter can be designed by performing simple calculations. It need to follow regulation by the output voltage and the maximum load current, as well as maximum and minimum input voltages. Begin by selecting an inductor value. Once L is know, choose the diode and capacitors.

Boost inductor

Inductor selection depends on input voltage, output voltage, maximum current , switching frequency and availability of inductor values. The following boost circuit equations are useful in choosing the inductor values based on the application. They allow the trading of peak current and inductor value while allowing for consideration of component availability and cost.

The peak inductor current is given by:

$$I_{Lpeak} = I_{LAVG} + \frac{\Delta I_L}{2}$$

$$I_{LAVG} = \frac{I_o}{1-D}$$

where:

ΔI_L is the inductor peak-to-peak current ripple and is decided by:

$$\Delta I_L = \frac{V_{in}}{L} \times \frac{D}{f_{OSC}}$$

D is the MOSFET turn on ratio and is decided by:

$$D = \frac{V_o - V_{in}}{V_o}$$

f_{OSC} is the switching frequency.

The inductor should be chosen to be able to handle this current and inductor saturation current rating should be greater than I_{PEAK} .

Diode selection

The output diode has average current of I_o , and peak current the same as the inductor's peak current and a voltage rating at least 1.5 times the output voltage. Schottky diode is recommended and it should be able to handle those current.

Output Capacitor

The AT1313 is specially compensated to be stable with capacitors which have a worst- case minimum value of 1uF at the particular V_{OUT} being set. Output ripple voltage requirements also determine the minimum value and type of capacitors. Output ripple voltage consists of two components the voltage drop caused by the switching current through the ESR of the output capacitor and the charging and discharging of the output capacitor:

$$V_{RIPPLE} = I_{LPEAK} \times ESR + \frac{V_o - V_{in}}{V_o} \times \frac{I_o}{C_{OUT} \times f_{OSC}}$$

For low ESR ceramic capacitors, the output ripple is dominated by the charging or discharging of the output capacitor.

PCB layout guidelines

Careful printed circuit layout is extremely important to avoid causing parasitical capacitance and line inductance. The following layout guidelines are recommended to achieve optimum performance.

- Please the boost converter diode and inductor close to the LX pin and no via. Keep traces short, direct, and wide.
- Please ceramic bypass capacitors near the input/output pin.
- Locate all feedback sense resistor as close to the feedback pins as possible.
- The ground connections of V_{IN} and V_{OUT} should be as close together as possible.

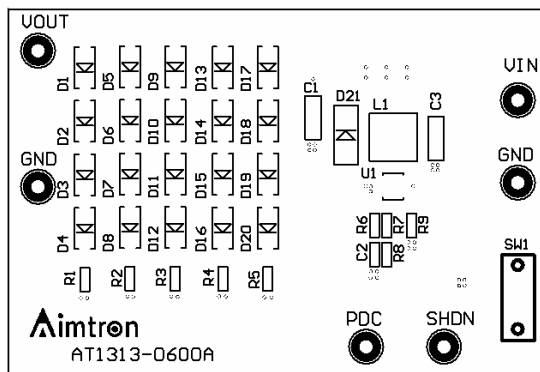
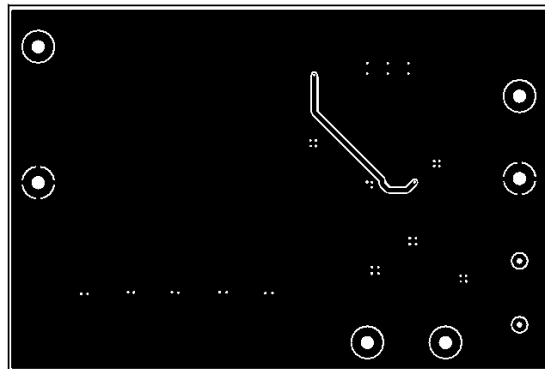
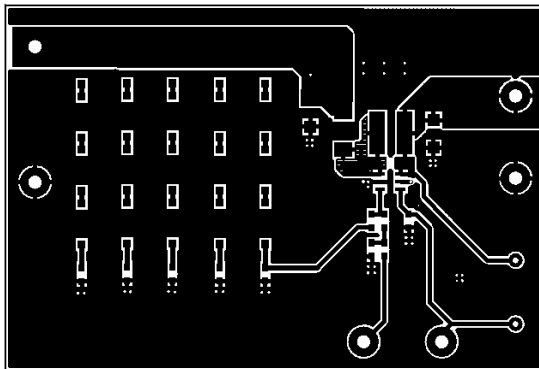

Small Outline SOT-26

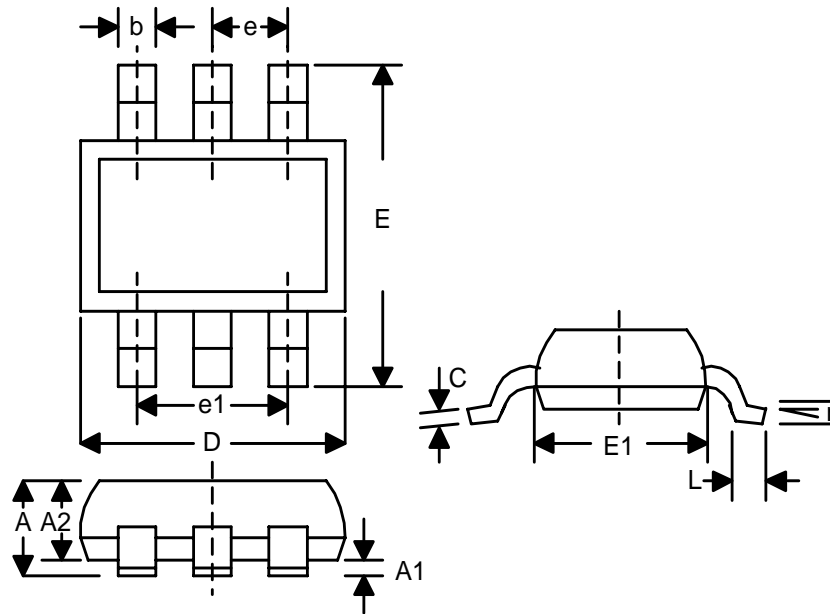

SYMBOL	INCHES		MILLIMETERS		NOTES
	MIN	MAX	MIN	MAX	
A	0.035	0.057	0.90	1.45	-
A1	0.000	0.006	0.00	0.15	-
A2	0.035	0.051	0.90	1.30	-
b	0.010	0.020	0.25	0.50	-
C	0.003	0.008	0.08	0.20	-
D	0.110	0.122	2.80	3.10	-
E	0.102	0.118	2.60	3.00	-
E1	0.059	0.069	1.50	1.75	-
L	0.014	0.022	0.35	0.55	-
e	0.037ref		0.95ref		-
e1	0.075ref		1.90ref		-
r	0 ⁰	10 ⁰	0 ⁰	10 ⁰	-

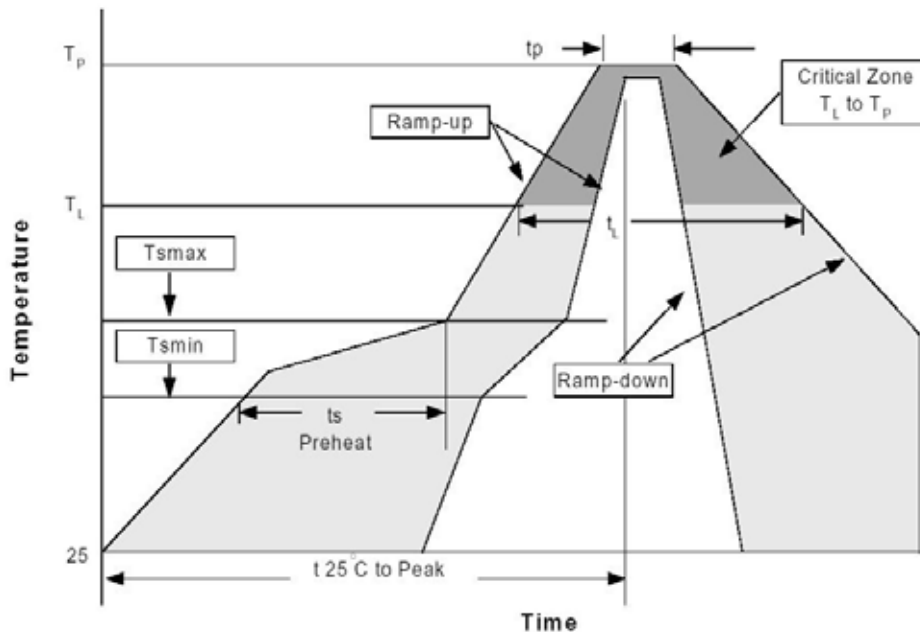
Reflow Profiles

Profile Feature	Sn-Pb Eutectic Assembly		Pb-Free Assembly	
	Large Body Pkg. thickness ≥2.5mm or Pkg. volume ≥350mm ³	Small Body Pkg. thickness <2.5mm or Pkg. volume <350mm ³	Large Body Pkg. thickness ≥2.5mm or Pkg. volume ≥350mm ³	Small Body Pkg. thickness <2.5mm or Pkg. volume <350mm ³
Average ramp-up rate (T _L to T _P)	3°C/second max.		3°C/second max.	
Preheat -Temperature Min(T _{smin}) -Temperature Max (T _{smax}) -Time (min to max)(t _s)	100°C 150°C 60-120 seconds		150°C 200°C 60-180 seconds	
T _{smax} to T _L -Ramp-up Rate			3°C/second max.	
Time maintained above: -Temperature (T _L) -Time (t _L)	183°C 60-150 seconds		217°C 60-150 seconds	
Peak Temperature(T _P)	225+0/-5°C	240+0/-5°C	245+0/-5°C	250+0/-5°C
Time within 5°C of actual Peak Temperature (t _p)	10-30 seconds	10-30 seconds	10-30 seconds	20-40 seconds
Ramp-down Rate	6°C/second max.		6°C/second max.	
Time 25°C to Peak Temperature	6 minutes max.		8 minutes max.	

*All temperatures refer to topside of the package, measured on the package body surface.