



AU6372

**USB2.0 Single LUN
Multiple Flash Card Reader Controller**

Technical Reference Manual



AU6372

USB2.0 Single LUN

Multiple Flash Card Reader Controller



Copyright

Copyright © 1997 - 2007. Alcor Micro, Corp. All Rights Reserved. No part of this data sheet may be reproduced, transmitted, transcribed, stored in a retrieval system or translated into any language or computer language, in any form or by any means, electronic, mechanical, magnetic, optical, chemical, manual or otherwise, without prior written permission from Alcor Micro, Corp.

Trademark Acknowledgements

The company and product names mentioned in this document may be the trademarks or registered trademarks of their manufacturers.

Disclaimer

Alcor Micro, Corp. reserves the right to change this product without prior notice. Alcor Micro, Corp. makes no warranty for the use of its products and bears no responsibility for any error that appear in this document. Specifications are subject to change without prior notice.

Revision History

Date	Revision	Description
Dec 2007	1.00W	Official release

Contact Information:

Web site: <http://www.alcormicro.com/>

Taiwan

Alcor Micro, Corp.
4F, No 200 Kang Chien Rd., Nei Hu,
Taipei, Taiwan, R.O.C.
Phone: 886-2-8751-1984
Fax: 886-2-2659-7723

Santa Clara Office

2901 Tasman Drive, Suite 206
Santa Clara, CA 95054
USA
Phone: (408) 845-9300
Fax: (408) 845-9086

China ShenZhen Office

Rm.2407-08, Industrial Bank Building
No.4013, Shennan Road,
ShenZhen,China. 518026
Phone: (0755) 8366-9039
Fax: (0755) 8366-9101

Los Angeles Office

9070 Rancho Park Court
Rancho Cucamonga, CA 91730
USA
Phone: (909) 483-8821
Fax: (909) 944-0464



Alcor Micro, Corp.

www.alcormicro.com

<Memo>



Table of Contents

1. Introduction	1
1.1 Description.....	1
1.2 Features.....	1
2. Application Block Diagram	2
3. Pin Assignment	3
4. System Architecture and Reference Design	6
4.1 AU6372 Block Diagram	6
5. Electrical Characteristics	7
5.1 Absolute Maximum Ratings.....	7
5.2 Recommended Operating Conditions	7
5.3 General DC Characteristics	7
5.4 DC Electrical Characteristics of 3.3V I/O Cells.....	8
5.5 USB Transceiver Characteristics	8
6. Mechanical Information	11
7. Abbreviations	12



List of Figures

Figure 2.1 Block Diagram.....	2
Figure 3.1 Pin Assignment Diagram	3
Figure 4.1 AU6372 Block Diagram	6
Figure 6.1 Mechanical Information Diagram	11

List of Tables

Table 3.1 Pin Descriptions	4
Table 5.1 Absolute Maximum Ratings	7
Table 5.2 Recommended Operating Conditions	7
Table 5.3 General DC Characteristics	7
Table 5.4 DC Electrical Characteristics of 3.3V I/O Cells	8
Table 5.5 Electrical characteristics	8
Table 5.6 Static characteristic : Digital pin	9
Table 5.7 Static characteristic : Analog I/O pins (DP/DM)	9
Table 5.8 Dynamic characteristic : Analog I/O pins (DP/DM)	10



1. Introduction

1.1 Description

The AU6372 is a highly integrated single chip media USB card reader controller that supports all popular form factor digital cards, such as SD, MMC, MS, MS Pro, MS Duo and XD. In addition to the small form factor and low BOM cost the solution also implement high performance operation a sophisticated DMA engine.

With the compliance with USB Storage Class V1.0, AU6372 not only exhibits wide acceptance in various OS platforms, its multiple slot design further enables the solution adapters become the content exchange center for mobile media. It can read digital contents stored on memory card designed to cover a wide area of applications such as digital cameras, PDAs, MP3 players and smart phones...etc. With the AU6372, users can transfer digital data between flash memory card and PC or these electronic devices.

The AU6372 used 48 pin package specifically designed for small foot print application, such as Note book and printer.

In addition to its high performance and outstanding compatibility, the solution of AU6372 comes with a user-friendly utility to enhance users' experience. Moreover, AU6372 integrates power switch to reduce the overall BOM cost.

1.2 Features

- Supports USB 2.0 specification and USB Device Class Definition for Mass Storage, Bulk-Transport V1.0
- Supports SD/MMC/MS/MS_Pro/MS_Duo/xD/SMC compatible flash card in 48 pin package
- Support SD spec up to ver.2.0 (SDHC)
- Support MMC spec up to ver.4.2
- Support MS 1.43 / MSPRO 1.04. MSPRO-HG compatible with 4-bit interface.
- Support xD 1.2 / SM 2003
- A built-in DMA engine for data transmission performance enhancement
- Work with default driver from Windows ME/2000/XP and Mac OS.
- Ping-pong FIFO implementation for concurrent bus operation
- Supports multiple sector burst transfer for optimized performance
- Supports Dynamic Icon Utility to enhance user experience
- Supports LED for bus activities indication
- Power switch integrated to reduce production BOM cost
- Support power saving mode for NoteBook solution



2. Application Block Diagram

The following application drawing demonstrates a typical card reader block diagram using AU6372. By connecting one card reader to a desktop or notebook PC through USB bus, the AU6372 becomes a bus-powered, high speed USB card reader, which can be used as a bridge for data transfer between Desktop PC and Notebook PC.

Figure 2.1 Block Diagram

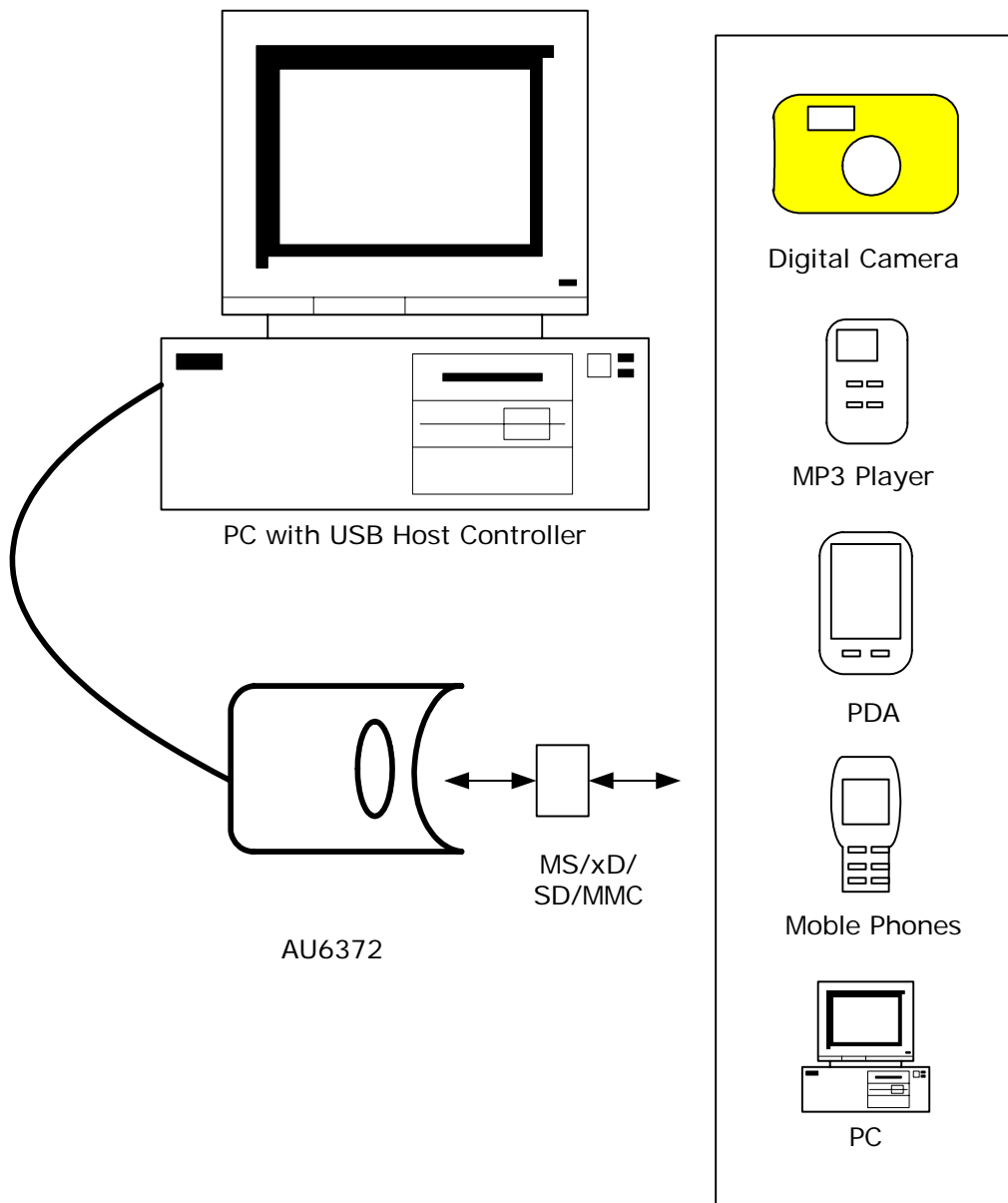



3. Pin Assignment

The AU6372 is delivered in 48pin LQFP form factor. Documented below is a figure shows signal names of each pin and a table in the following page describes each pin in more details.

Figure 3.1 Pin Assignment Diagram

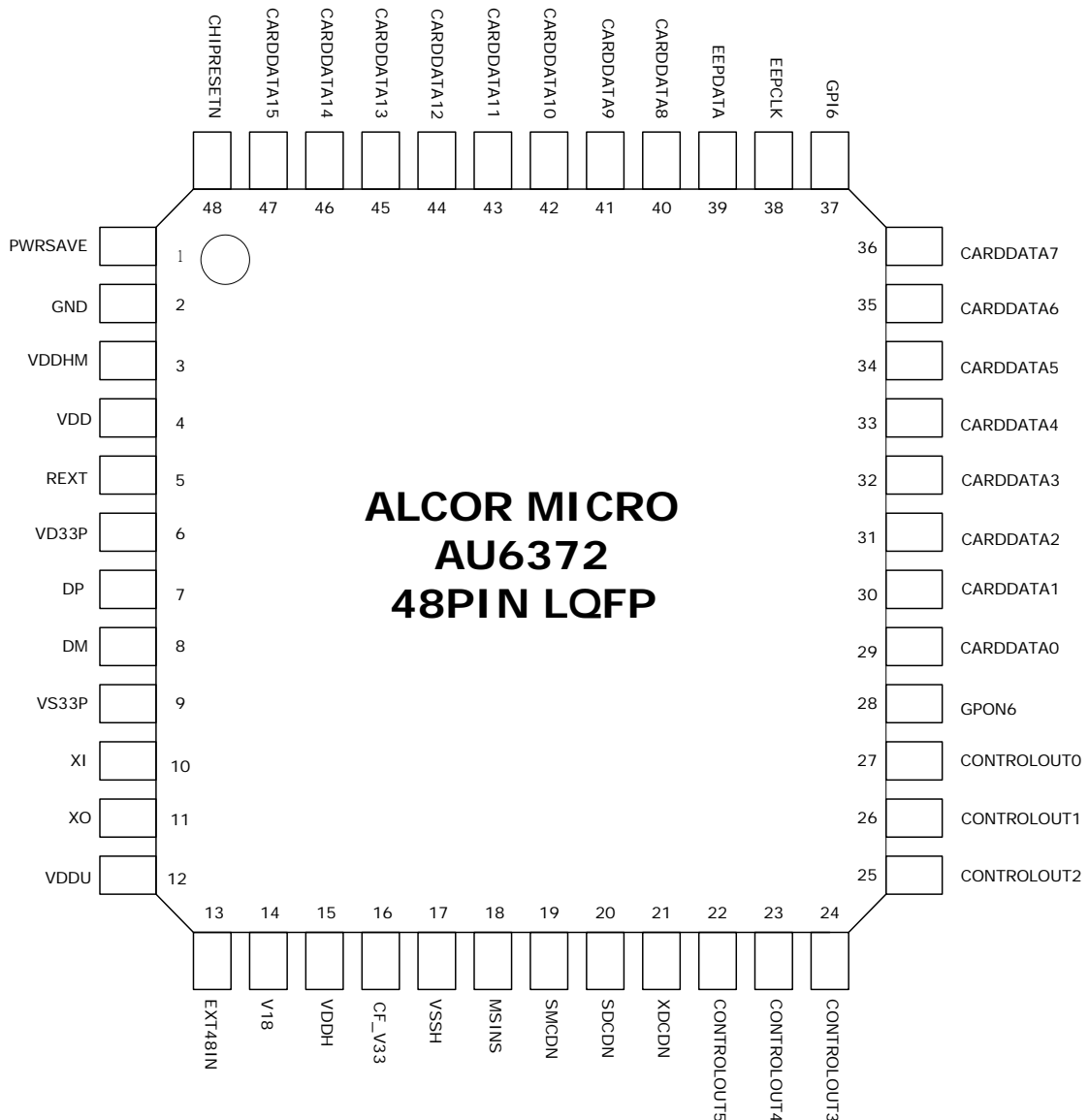



Table 3.1 Pin Descriptions

Pin #	Pin Name	I/O	Description
1	PWRSAVE	I	"0" is enable ; "1" is disable
2	GND	I	Core Power Gound
3	VDDHM		3.3V for IO pad
4	VDD		Core Power 1.8V
5	REXT	O	External Resistor 330 to Ground
6	VD33P		3.3V Power
7	DP	I/O	USB DP
8	DM	I/O	USB DM
9	VS33P		Ground Power
10	XI	I	12 MHz crystal input.
11	XO	O	12 MHz crystal output.
12	VDDU		UTMI Power 1.8 V
13	EXT48IN		Reserved for 48MHz input
14	V18	O	Core Power 1.8V
15	VDDH	I	3.3V for IO pad
16	CF_V33	O	Card Power 3.3V
17	VSSH	IO	Power Ground
18	MSINS	I	MS Card detect, Pull down when suspend otherwise Pull Up
19	SMCDN	I	SMC Card detect, Pull down when suspend otherwise Pull Up
20	SDCDN	I	SD Card detect, Pull down when suspend otherwise Pull Up
21	XDCDN	I	XD Card detect, Pull down when suspend otherwise Pull Up
22	CONTROLOUT5	O	XDWRN
23	CONTROLOUT4	O	XDRDN
24	CONTROLOUT3	O	XDCEN
25	CONTROLOUT2	O	XDALE
26	CONTROLOUT1	O	MSCLK and XDCLE
27	CONTROLOUT0	O	SDCLK and MSBS
28	GPON6	O	LED ON for card exists,LED Off when card not exists or in suspend mode when Full speed mode ("1": Exist; "0": Nonexist)
29	CARDDATA0	I/O	MSDATA0,and SDCMD
30	CARDDATA1	I/O	MSDATA1,XDWPN



Pin #	Pin Name	I/O	Description
31	CARDDATA2	I/O	MSDATA2,and SDWP
32	CARDDATA3	I/O	MSDATA3 and XDRBN
33	CARDDATA4	I/O	SDDATA0
34	CARDDATA5	I/O	SDDATA1
35	CARDDATA6	I/O	SDDATA2
36	CARDDATA7	I/O	SDDATA3
37	GPI6	I	NOT_CIS_CHECK_DETECTION ("1":Disable xD CIS_CHECK; "0":Enable xD CIS_CHECK)
38	EEPCLK	I	EEPROM serial clock.
39	EEPDATA	O	EEPROM for PID,VID customization.
40	CARDDATA8	I/O	XDDATA0, and SDDATA4
41	CARDDATA9	I/O	XDDATA1, and SDDATA5
42	CARDDATA10	I/O	XDDATA2, and SDDATA6
43	CARDDATA11	I/O	XDDATA3, and SDDATA7
44	CARDDATA12	I/O	XDDATA4
45	CARDDATA13	I/O	XDDATA5
46	CARDDATA14	I/O	XDDATA6
47	CARDDATA15	I/O	XDDATA7
48	CHIPRESETN	I	ResetN (low active to reset the whole chip), must be pull up with RC.



4. System Architecture and Reference Design

4.1 AU6372 Block Diagram

Figure 4.1 AU6372 Block Diagram

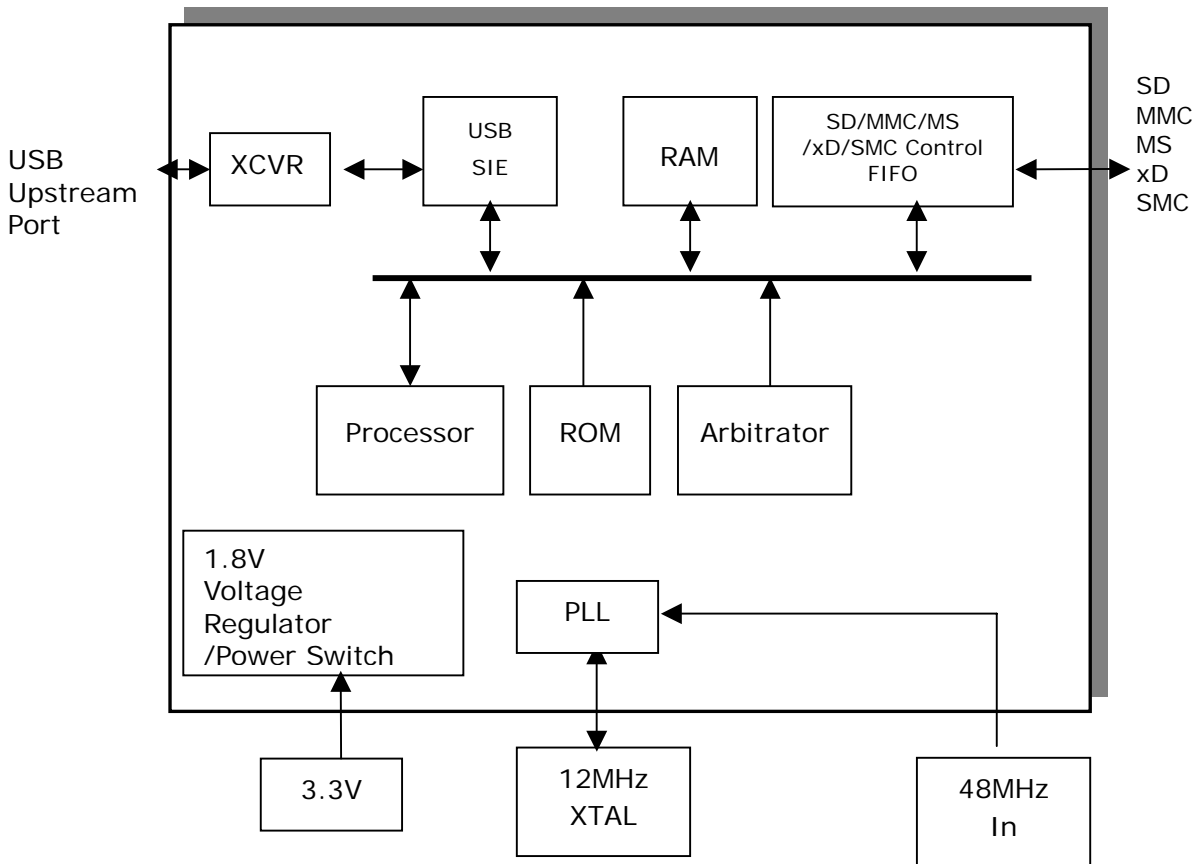

5. Electrical Characteristics

5.1 Absolute Maximum Ratings

Table 5.1 Absolute Maximum Ratings

SYMBOL	PARAMETER	RATING	UNITS
V_{DDH}	Power Supply	-0.3 to 3.6	V
V_{IN}	Input Signal Voltage	-0.3 to $V_{DDH} + 0.3$	V
T_{STG}	Storage Temperature	-40 to 150	$^{\circ}C$

5.2 Recommended Operating Conditions

Table 5.2 Recommended Operating Conditions

SYMBOL	PARAMETER	MIN	TYP	MAX	UNITS
V_{DDH}	Power Supply	3.0	3.3	3.6	V
V_{DD} V_{18}	Digital Supply	1.62	1.8	1.98	V
V_{IN}	Input Signal Voltage	0	3.3	3.6	V
T_{OPR}	Operating Temperature	0		85	$^{\circ}C$

5.3 General DC Characteristics

Table 5.3 General DC Characteristics

SYMBOL	PARAMETER	CONDITIONS	MIN	TYP	MAX	UNITS
I_{IN}	Input current	No pull-up or pull-down	-10	± 1	10	μA
I_{OZ}	Tri-state leakage current		-10	± 1	10	μA
C_{IN}	Input capacitance	Pad Limit		2.8		ρF
C_{OUT}	Output capacitance	Pad Limit		2.8		ρF
C_{BID}	Bi-directional buffer capacitance	Pad Limit		2.8		ρF

5.4 DC Electrical Characteristics of 3.3V I/O Cells

Table 5.4 DC Electrical Characteristics of 3.3V I/O Cells

SYMBOL	PARAMETER	CONDITIONS	Limits			UNIT
			MIN	TYP	MAX	
V_{DDH}	Power supply	3.3V I/O	3.0	3.3	3.6	V
V_{il}	Input low voltage	LVTTL			0.8	V
V_{ih}	Input high voltage		2.0			V
V_{ol}	Output low voltage	$ I_{ol} = 2\sim 16\text{mA}$			0.4	V
V_{oh}	Output high voltage	$ I_{oh} = 2\sim 16\text{mA}$	2.4			V
R_{pu}	Input pull-up resistance	PU=high, PD=low	55	75	110	$K\Omega$
R_{pd}	Input pull-down resistance	PU=low, PD=high	40	75	150	$K\Omega$
I_{in}	Input leakage current	$V_{in} = V_{DDH}$ or 0	-10	± 1	10	μA
I_{oz}	Tri-state output leakage current		-10	± 1	10	μA

5.5 USB Transceiver Characteristics

Table 5.5 Electrical characteristics

Symbol	Parameter	Conditions	Min.	Typ.	Max.	Unit
VD33	Analog supply Voltage		3.0	3.3	3.6	V
VDDU VDDA	Digital supply Voltage		1.62	1.8	1.98	V
I_{cc}	Operating supply current	High speed operating at 480 MHz			55	mA



Table 5.6 Static characteristic : Digital pin

Symbol	Parameter	Conditions	Min.	Typ.	Max.	Unit
Input levels						
V_{IL}	Low-level input voltage				0.8	V
V_{IH}	High-level input voltage		2.0			V
Output levels						
V_{OL}	Low-level output voltage				0.2	V
V_{OH}	High-level output voltage		VDDH-0.2			V

Table 5.7 Static characteristic : Analog I/O pins (DP/DM)

Symbol	Parameter	Conditions	Min.	Typ.	Max.	Unit
USB2.0 Transceiver (HS)						
Input Levels (differential receiver)						
V_{HSDIFF}	High speed differential input sensitivity	$ V_{I(DP)} - V_{I(DM)} $ measured at the connection as application circuit	300			mV
V_{HSCM}	High speed data signaling common mode voltage range		-50		500	mV
V_{HSSQ}	High speed squelch detection threshold	Squelch detected			100	mV
		No squelch detected	150			mV
V_{HSDSC}	High speed disconnection detection threshold	Disconnection detected	625			mV
		Disconnection not detected			525	mV
Output Levels						
V_{HSOI}	High speed idle level output voltage(differential)		-10		10	mV
V_{HSOL}	High speed low level output voltage(differential)		-10		10	mV
V_{HSOH}	High speed high level output voltage(differential)		-360		400	mV
V_{CHIRPJ}	Chirp-J output voltage (differential)		700		1100	mV
V_{CHIRPK}	Chirp-K output voltage (differential)		-900		-500	mV
Resistance						
R_{DRV}	Driver output impedance	Equivalent resistance used as internal chip only	3	6	9	Ω



		Overall resistance including external resistor	40.5	45	49.5	
Termination						
V_{TERM}	Termination voltage for pull-up resistor on pin RPU		3.0		3.6	V
USB1.1 Transceiver (FS)						
Input Levels (differential receiver)						
V_{DI}	Differential input sensitivity	$ V_{I(DP)} - V_{I(DM)} $	0.2			V
V_{CM}	Differential common mode voltage		0.8		2.5	V
Input Levels (single-ended receivers)						
V_{SE}	Single ended receiver threshold		0.8		2.0	V
Output levels						
V_{OL}	Low-level output voltage		0		0.3	V
V_{OH}	High-level output voltage		2.8		3.6	V

Table 5.8 Dynamic characteristic : Analog I/O pins (DP/DM)

Symbol	Parameter	Conditions	Min.	Typ.	Max.	Unit
Driver Characteristics						
High-Speed Mode						
t_{HSR}	High-speed differential rise time		500			ps
t_{HSF}	High-speed differential fall time		500			ps
Full-Speed Mode						
t_{FR}	Rise time	CL=50pF ; 10 to 90% of $ V_{OH}-V_{OL} $;	4		20	ns
t_{FF}	Fall time	CL=50pF ; 90 to 10% of $ V_{OH}-V_{OL} $;	4		20	ns
t_{FRMA}	Differential rise/fall time matching (t_{FR} / t_{FF})	Excluding the first transition from idle mode	90		110	%
V_{CRS}	Output signal crossover voltage	Excluding the first transition from idle mode	1.3		2.0	V



6. Mechanical Information

Figure 6.1 Mechanical Information Diagram

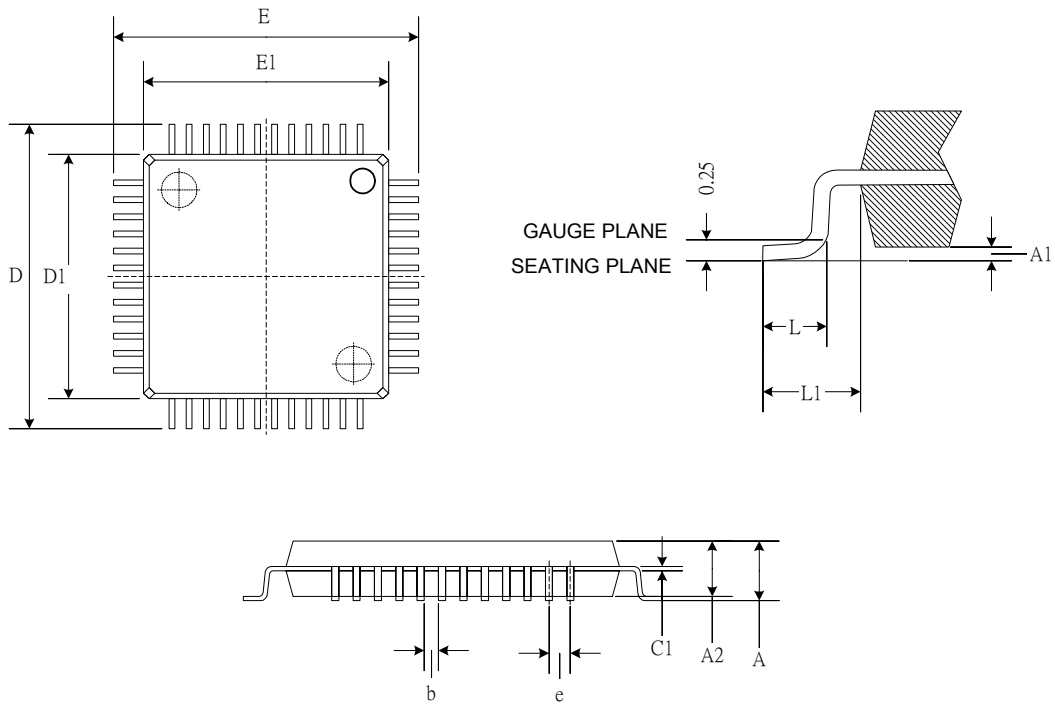

SYMBOLS	MIN.	MAX.
A	--	1.6
A1	0.05	0.15
A2	1.35	1.45
c1	0.09	0.16
D	9.00 BSC	
D1	7.00 BSC	
E	9.00 BSC	
E1	7.00 BSC	
e	0.5 BSC	
b	0.17	0.27
L	0.45	0.75
L1	1 REF	

1. JEDEC OUTLINE: MS-026 BBC
2. DIMENSIONS D1 AND E1 DO NOT INCLUDE MOLD PROTRUSION. ALLOWABLE PROTRUSION IS 0.25mm PER SIDE. D1 AND E1 ARE MAXIMUM PLASTIC BODY SIZE DIMENSIONS INCLUDING MOLD MISMATCH.
3. DIMENSION b DOES NOT INCLUDE DAMBAR PROTRUSION. ALLOWABLE DAMBAR PROTRUSION SHALL NOT CAUSE THE LEAD WIDTH TO EXCEED THE MAXIMUM b DIMENSION BY MORE THAN 0.08mm



7. Abbreviations

In this chapter some of the terms and abbreviations used throughout the technical reference manual are listed as follows.

SIE	Serial Interface Engine
MS	Memory Stick
SD	Secure Digital
MMC	Multimedia Card
UTMI	USB Transceiver Macrocell Interface

About Alcor Micro, Corp.

Alcor Micro, Corp. designs, develops and markets highly integrated and advanced peripheral semiconductor, and software driver solutions for the personal computer and consumer electronics markets worldwide. We specialize in USB solutions and focus on emerging technology such as USB and IEEE 1394. The company offers a range of semiconductors including controllers for USB hub, integrated keyboard/USB hub and USB Flash memory card reader...etc. Alcor Micro, Corp. is based in Taipei, Taiwan, with sales offices in Taipei, Japan, Korea and California. Alcor Micro is distinguished by its ability to provide innovative solutions for spec-driven products. Innovations like single chip solutions for traditional multiple chip products and on-board voltage regulators enable the company to provide cost-efficiency solutions for the computer peripheral device OEM customers worldwide.