



查询AU6375供应商

捷多邦，专业PCB打样工厂，24小时加急出货

**ALCOR** Alcor Micro Corp.

# Data Book

## AU6375

### USB2.0 Multi-LUN Flash Card Reader Controller

### Technical Reference Manual

**Product Specification**

**Official Release**

**Revision 1.01W**

**Public**

**May 2006**





## Data sheet status

Objective specification	This data sheet contains target specifications for product development.
Preliminary specification	This data sheet contains preliminary data; supplementary data may be published later.
Product specification	This data sheet contains final product specifications.

## Revision History

<b>Date</b>	<b>Revision</b>	<b>Description</b>
Jan 2006	1.00W	Official release
May 2006	1.01W	Add "Support SD 2.0 specification" feature



**Alcor Micro Corp.**

---

**Copyright Notice**

Copyright 1997 - 2006  
Alcor Micro Corp.  
All Rights Reserved.

**Trademark Acknowledgements**

The company and product names mentioned in this document may be the trademarks or registered trademarks of their manufacturers.

**Disclaimer**

Alcor Micro Corp. reserves the right to change this product without prior notice. Alcor Micro Corp. makes no warranty for the use of its products and bears no responsibility for any error that appear in this document. Specifications are subject to change without prior notice.



# Table of Contents

<b>1</b>	<b><a href="#">Introduction</a></b> .....	<b>6</b>
	<a href="#">1.1 Description</a> .....	6
	<a href="#">1.2 Features</a> .....	6
<b>2</b>	<b><a href="#">Application Block Diagram</a></b> .....	<b>7</b>
<b>3</b>	<b><a href="#">Pin Assignment</a></b> .....	<b>8</b>
<b>4</b>	<b><a href="#">System Architecture and Reference Design</a></b> .....	<b>12</b>
	<a href="#">4.1 AU6375 Block Diagram</a> .....	12
<b>5</b>	<b><a href="#">Electrical Characteristics</a></b> .....	<b>13</b>
	<a href="#">5.1 Absolute Maximum Ratings</a> .....	13
	<a href="#">5.2 Recommended Operating Conditions</a> .....	13
	<a href="#">5.3 General DC Characteristics</a> .....	13
	<a href="#">5.4 DC Electrical Characteristics for 5 volts operation</a> .....	14
	<a href="#">5.5 USB Transceiver Characteristics</a> .....	15
	<a href="#">5.6 Power Switch Feature</a> .....	19
<b>6</b>	<b><a href="#">Mechanical Information</a></b> .....	<b>20</b>
<b>7</b>	<b><a href="#">Abbreviations</a></b> .....	<b>21</b>



## List of Figures

2.1	<a href="#">Block Diagram</a> .....	7
3.1	<a href="#">Pin Assignment Diagram</a> .....	8
4.1	<a href="#">AU6375 Block diagram</a> .....	12
5.1	<a href="#">Card Detect Power-on Timing</a> .....	19
6.1	<a href="#">Mechanical Information Diagram</a> .....	20

## List of Tables

3.1	<a href="#">Pin Descriptions</a> .....	9
5.1	<a href="#">Absolute Maximum Ratings</a> .....	13
5.2	<a href="#">Recommended Operating Conditions</a> .....	13
5.3	<a href="#">General DC Characteristics</a> .....	13
5.4	<a href="#">DC Electrical Characteristics of 3.3V I/O Cells</a> .....	14
5.5	<a href="#">Recommended Operation Conditions</a> .....	15
5.6	<a href="#">Static characteristic : Digital in</a> .....	15
5.7	<a href="#">Static characteristic : Analog I/O pins ( DP/DM )</a> .....	16
5.8	<a href="#">Dynamic characteristic : Analog I/O pins ( DP/DM )</a> .....	18



# 1.0 Introduction

## 1.1 Description

The AU6375 is a single chip integrated USB 2.0 multimedia card reader controller that enables PC/DVD/Printer to read/write various type of flash media cards. Flash media cards such as CF, SMC, XD, SD, MMC, Memory Stick are widely used in digital camera, cell phone, PDA and MP3 player to store digital photos and compressed music.

Performance of AU6375 is maximized by implementing the latest and fastest card specification available from the industry.

Especially, AU6375 is designed with the high performance characteristic in flash card I/O speed. Users can easily and fast transfer the digital content among the different flash card.

## 1.2 Features

- Support USB V2.0 specification and USB Device Class Definition for Mass Storage, Bulk-Transport V1.0
- Support CF/MD/SD/MMC/MS/MS\_Pro/MS\_Duo/xD/SMC compatible flash card
- Support the latest flash card specification: CF 3.0 (16-bit IDE mode), SD1.1 (HS-SD), MMC4.0 (8-bit), MSPro parallel mode (4-bit), xD 1.2
- Support SD 2.0 specification
- Hardware DMA engine integrated for performance enhancement.
- Work with default driver from Windows ME/2000/XP and Mac OS X; Windows 98/2000(SP1/SP2) and Mac OS 9 are supported by vendor driver from Alcor.
- Ping-pong FIFO implementation for concurrent bus operation
- Support multiple sectors transfer optimize performance
- Support slot-to-slot read/write operation
- Support Dynamic Icon Utility
- Support LED for bus operating indication
- Power switch integrated to reduce production BOM cost
- 30MHz 8051 CPU
- Built in 3.3V to 2.5V regulator
- CF slot can be disabled by pin4 in 4.5 LUN mode
- Runs at 12MHz crystal
- Available in 100-pin LQFP package



## 2.0 Application Block Diagram

Following application diagram demonstrates a typical card reader using the AU6375 chip. By connecting the card reader to a desktop or notebook PC through USB bus, the AU6375 becomes a bus-powered, high speed USB card reader, which can be used as a bridge for data transfer between Desktop PC and Notebook PC.

### 2.1 Block Diagram

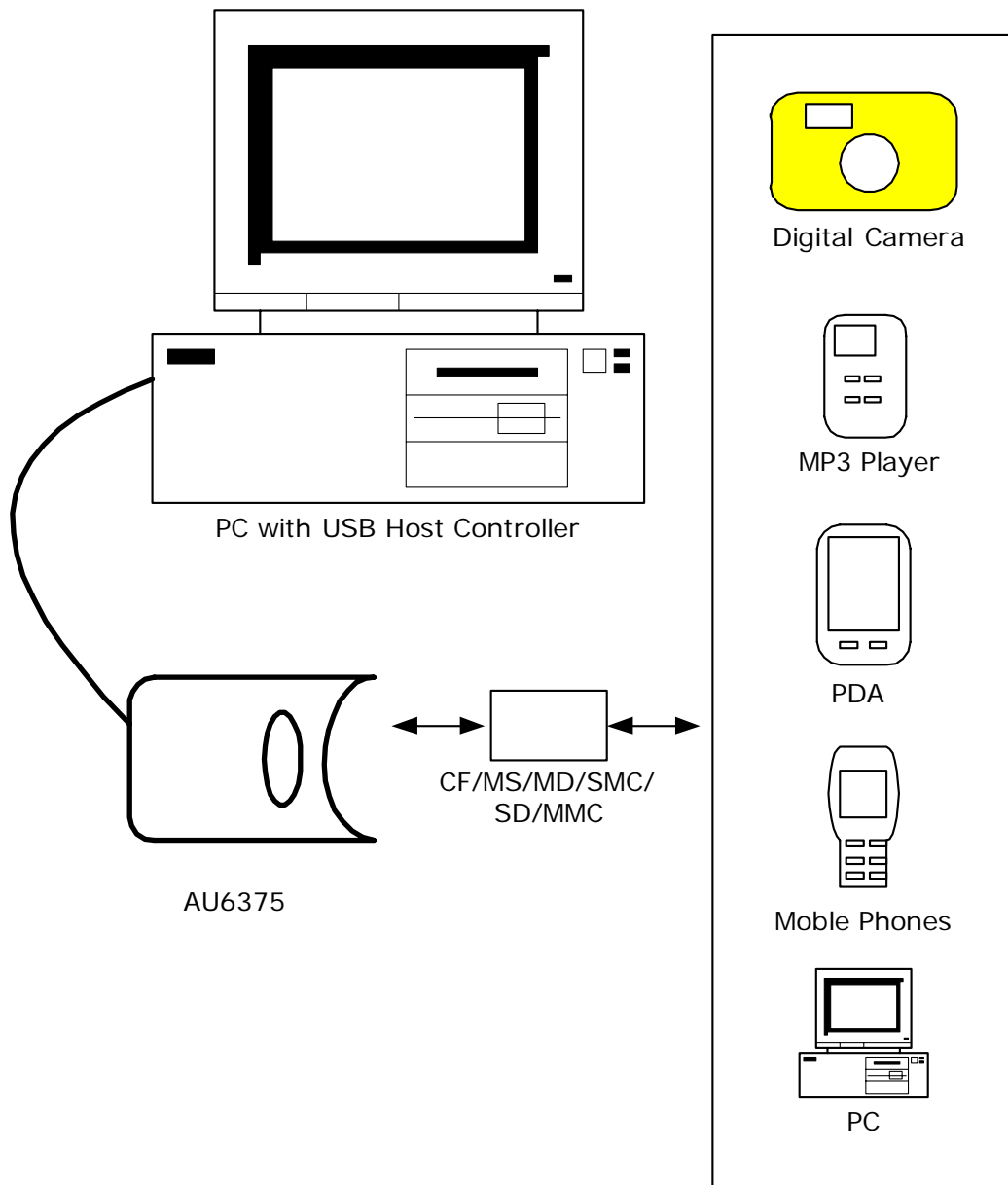







Table 3.1 Pin Descriptions

Pin #	Pin Name	I/O	Description
1	CFAD0	O	CF Address0
2	CLED	O	LED indicator for flash card operating
3	CFPWSW	O	CF Card Power Switch. ('0':On; '1':Off)
4	CFEN	I	CF slot enable ('0':Enable[Default]; '1':Disable); Only support in 4.5LUN mode
5	DECV	I	Device current value. ('0':Low power[Default]; '1':High power)
6	RFU1	I	Reserved; Floating
7	XDCISN	I	xD check CIS. ('0':Enable[Default]; '1':Disable)
8	GPI1	I	Slot Mode Select (GPI1,GPI0)=(0,0): Reserved (GPI1,GPI0)=(0,1): 2 LUN (GPI1,GPI0)=(1,0): 4.5 LUN [Default] (GPI1,GPI0)=(1,1) : 1 LUN
9	GPI0	I	Slot Mode Select (GPI1,GPI0)=(0,0): Reserved (GPI1,GPI0)=(0,1): 2 LUN (GPI1,GPI0)=(1,0): 4.5 LUN [Default] (GPI1,GPI0)=(1,1) : 1 LUN
10	EEPDATA	IO	EEPDATA
11	EEPCLK	O	EEPCLK
12	CHIPRESETN	I	Chip Reset
13	RFU3	I	Reserved; Floating
14	VDDA	A	Analog 2.5V VDD
15	GNDA	A	Analog 2.5V GND
16	RPU	IO	Connect 1.5K pull up Res. to 3.3V VDD
17	AVDD	PWR	Analog Power 3.3V
18	NC		
19	NC		
20	DP	IO	DP
21	DM	IO	DM
22	NC		
23	NC		
24	AVSS	PWR	Analog GND
25	RREF	IO	Connect 1K Res. to GND for impedance match
26	PVDD	PWR	OSC Power 3.3V
27	XI	I	12MHz Crystal Input
28	XO	O	12MHz Crystal Output
29	PVSS	PWR	OSC GND
30	VDD25V	O	2.5V Power Output for Core Power
31	VDDH	I	IO Power 3.3V
32	VSSH	I	IO GND
33	SMALE	O	SMC ALE
34	SMCDN	I	SMC Card Detect ("0":Detected; "1":Undetected)



Pin #	Pin Name	I/O	Description
35	SMCLE	O	SMC CLE
36	SMDATA0	IO	xD/SMC Data0
37	SMDATA1	IO	xD/SMC Data1
38	SMDATA2	IO	xD/SMC Data2
39	SMDATA3	IO	xD/SMC Data3
40	SMDATA4	IO	xD/SMC Data4
41	SMDATA5	IO	xD/SMC Data5
42	SMDATA6	IO	xD/SMC Data6
43	SMDATA7	IO	xD/SMC Data7
44	SMRBN	I	SMC RBN
45	SMRDN	O	SMC RDN
46	SMWRN	O	SMC WRN
47	XDCDN	I	XD Card Detect ("0": Detected; "1": Undetected)
48	XDCEN	O	XD CEN
49	XDWPN	IO	XD WPN
50	NC		
51	VDD33	I	Power Switch 3.3V
52	CF_V33	O	CF Power
53	XD_V33	O	XD Power
54	MS_V33	O	MS Power
55	SD_V33	O	SD Power
56	MSBS	O	MS BS
57	MSCLK	O	MS CLK
58	MSDATA0	IO	MS Data0
59	MSDATA1	IO	MS Data1
60	MSDATA2	IO	MS Data2
61	MSDATA3	IO	MS Data3
62	MSINS	I	MS Card Detect ("0": Detected; "1": Undetected)
63	SDCDN	I	SD Card Detect ("0": Detected; "1": Undetected)
64	SDCLK	O	SD CLK
65	SDCMD	IO	SD CMD
66	SDDATA0	IO	SD/MMC Data0
67	SDDATA1	IO	SD/MMC Data1
68	SDDATA2	IO	SD/MMC Data2
69	SDDATA3	IO	SD/MMC Data3
70	SDDATA4	IO	MMC Data4
71	SDDATA5	IO	MMC Data5
72	SDDATA6	IO	MMC Data6
73	SDDATA7	IO	MMC Data7
74	SDWP	I	SD Write Protect
75	NC		
76	VDD	I	Core Power 2.5V Input
77	GND	I	Core GND
78	CFWTN	I	CF WTN
79	CFWRN	O	CF WRN
80	CFRESETN	O	CF Reset
81	CFRDN	O	CF RDN
82	CFDATA9	IO	CF Data9



Pin #	Pin Name	I/O	Description
83	CFDATA8	IO	CF Data8
84	CFDATA7	IO	CF Data7
85	CFDATA6	IO	CF Data6
86	CFDATA5	IO	CF Data5
87	CFDATA4	IO	CF Data4
88	CFDATA3	IO	CF Data3
89	CFDATA2	IO	CF Data2
90	CFDATA1	IO	CF Data1
91	CFDATA15	IO	CF Data15
92	CFDATA14	IO	CF Data14
93	CFDATA13	IO	CF Data13
94	CFDATA12	IO	CF Data12
95	CFDATA11	IO	CF Data11
96	CFDATA10	IO	CF Data10
97	CFAD1	O	CF Address1
98	CFAD2	O	CF Address2
99	CFCDN	I	CF Card Detect ("0":Detected; "1":Undetected)
100	CFDATA0	IO	CF Data0



# 4.0 System Architecture and Reference Design

## 4.1 AU6375 Block Diagram

Figure 4.1 AU6375 Block Diagram

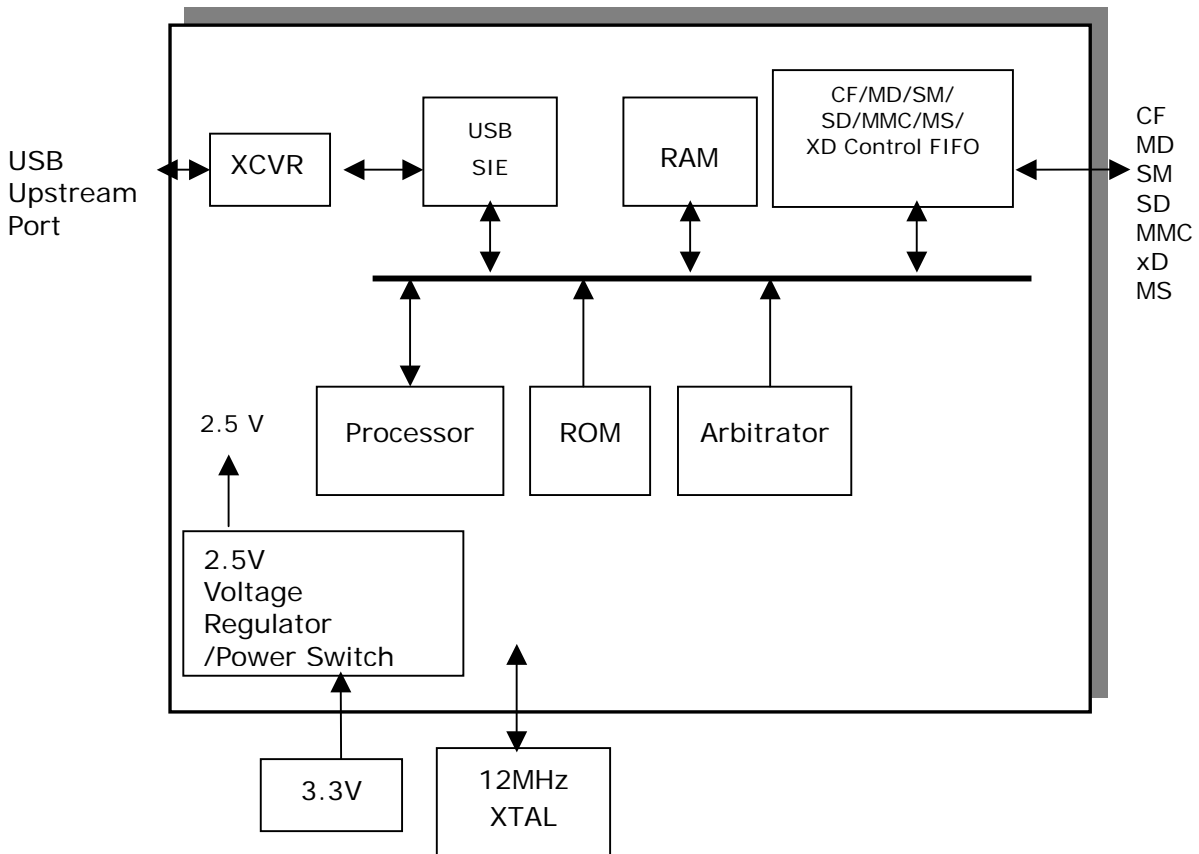



## 5.0 Electrical Characteristics

### 5.1 Absolute Maximum Ratings

Table 5.1 Absolute Maximum Ratings

SYMBOL	PARAMETER	RATING	UNITS
V <sub>CC</sub>	Power Supply	-0.3 to V <sub>CC</sub> +0.3	V
V <sub>IN</sub>	Input signal Voltage	-0.3 to 3.6	V
V <sub>OUT</sub>	Output signal Voltage	-0.3 to V <sub>CC</sub> +0.3	V
T <sub>STG</sub>	Storage Temperature	-40 to 150	°C

### 5.2 Recommended Operating Conditions

Table 5.2 Recommended Operating Conditions

SYMBOL	PARAMETER	MIN	TYP	MAX	UNITS
V <sub>CC</sub>	Power Supply	3.0	3.3	3.6	V
V <sub>DD</sub>	Digital Supply	2.25	2.5	2.75	V
V <sub>IN</sub>	Input signal Voltage	0	3.3	5.2	V
T <sub>OPR</sub>	Operating Temperature	0		85	°C

### 5.3 Leakage Current and Capacitance

Table 5.3 General DC Characteristics

SYMBOL	PARAMETER	CONDITIONS	MIN	TYP	MAX	UNITS
I <sub>IN</sub>	Input current	no pull-up or pull-down	-10	±1	10	μA
I <sub>OZ</sub>	Tri-state leakage current		-10	±1	10	μA
C <sub>IN</sub>	Input capacitance	Pad Limit		2.8		ρF
C <sub>OUT</sub>	Output capacitance	Pad Limit		2.8		ρF
C <sub>BID</sub>	Bi-directional buffer capacitance	Pad Limit		2.8		ρF



## 5.4 DC Electrical Characteristics of 3.3V I/O Cells

**Table 5.4 DC Electrical Characteristics of 3.3V I/O Cells**

SYMBOL	PARAMETER	CONDITIONS	Limits			UNIT
			MIN	TYP	MAX	
$V_{CC}$	Power supply	3.3V I/O	3.0	3.3	3.6	V
$V_{il}$	Input low voltage	LVTTTL			0.8	V
$V_{ih}$	Input high voltage		2.0			V
$V_{ol}$	Output low voltage	$ I_{ol}  = 2 \sim 16\text{mA}$			0.4	V
$V_{oh}$	Output high voltage	$ I_{oh}  = 2 \sim 16\text{mA}$	2.4			V
$R_{pu}$	Input pull-up resistance	PU=high, PD=low	40	75	190	$K\Omega$
$R_{pd}$	Input pull-down resistance	PU=low, PD=high	40	75	190	$K\Omega$
$I_{in}$	Input leakage current	$V_{in} = V_{CC}$ or 0	-10	$\pm 1$	10	$\mu A$
$I_{oz}$	Tri-state output leakage current		-10	$\pm 1$	10	$\mu A$



## 5.5 USB Transceiver Characteristics

**Table 5.5 Electrical characteristics**

Symbol	Parameter	Conditions	Min.	Typ.	Max.	Unit
AVCC	Analog supply Voltage		3.0	3.3	3.6	V
VCC	Digital supply Voltage		2.25	2.5	2.75	V
I <sub>CC</sub>	Operating supply current	High speed operating at 480 MHz			73	mA
I <sub>CC(susp)</sub>	Suspend supply current	In suspend mode, current with 1.5kΩ pull-up resistor on pin RPU disconnected			120	μA

**Table 5.6 Static characteristic : Digital pin**

Symbol	Parameter	Conditions	Min.	Typ.	Max.	Unit
Input levels						
V <sub>IL</sub>	Low-level input voltage				0.8	V
V <sub>IH</sub>	High-level input voltage		2.0			V
Output levels						
V <sub>OL</sub>	Low-level output voltage				0.2	V
V <sub>OH</sub>	High-level output voltage		VCC-0.2			V

**AVCC=3.0V~3.6V ; VCC=2.25V~2.75V ; Temp=0°C~85°C**



**Table 5.7 Static characteristic : Analog I/O pins (DP/DM)**

Symbol	Parameter	Conditions	Min.	Typ.	Max.	Unit
USB2.0 Transceiver (HS)						
Input Levels (differential receiver)						
$V_{HSDIFF}$	High speed differential input sensitivity	$ V_{I(DP)} - V_{I(DM)} $ measured at the connection as application circuit	300			mV
$V_{HSCM}$	High speed data signaling common mode voltage range		-50		500	mV
$V_{HSSQ}$	High speed squelch detection threshold	Squelch detected			100	mV
		No squelch detected	150			mV
$V_{HSDSC}$	High speed disconnection detection threshold	Disconnection detected	625			mV
		Disconnection not detected			525	mV
Output Levels						
$V_{HSOI}$	High speed idle level output voltage(differential)		-10		10	mV
$V_{HSOL}$	High speed low level output voltage(differential)		-10		10	mV
$V_{HSOH}$	High speed high level output voltage(differential)		-360		400	mV
$V_{CHIRPJ}$	Chirp-J output voltage (differential)		700		1100	mV
$V_{CHIRPK}$	Chirp-K output voltage (differential)		-900		-500	mV
Resistance						
$R_{DRV}$	Driver output impedance	Equivalent resistance used as internal chip only	3	6	9	$\Omega$
		Overall resistance including external resistor	40.5	45	49.5	
Termination						
$V_{TERM}$	Termination voltage for pull-up resistor on pin RPU		3.0		3.6	V
USB1.1 Transceiver (FS/LS)						
Input Levels (differential receiver)						
$V_{DI}$	Differential input sensitivity	$ V_{I(DP)} - V_{I(DM)} $	0.2			V
$V_{CM}$	Differential common mode voltage		0.8		2.5	V
Input Levels (single-ended receivers)						





$V_{SE}$	Single ended receiver threshold		0.8		2.0	V
Output levels						
$V_{OL}$	Low-level output voltage		0		0.3	V
$V_{OH}$	High-level output voltage		2.8		3.6	V

**AVCC=3.0V~3.6V ; VCC=2.25V~2.75V ; Temp=0°C ~85°C**

**Table 5.8 Dynamic characteristic : Analog I/O pins (DP/DM)**

Symbol	Parameter	Conditions	Min.	Typ.	Max.	Unit
Driver Characteristics						
High-Speed Mode						
$t_{HSR}$	High-speed differential rise time		500			ps
$t_{HSF}$	High-speed differential fall time		500			ps
Full-Speed Mode						
$t_{FR}$	Rise time	CL=50pF ; 10 to 90% of $ V_{OH}-V_{OL} $ ;	4		20	ns
$t_{FF}$	Fall time	CL=50pF ; 90 to 10% of $ V_{OH}-V_{OL} $ ;	4		20	ns
$t_{FRMA}$	Differential rise/fall time matching ( $t_{FR} / t_{FF}$ )	Excluding the first transition from idle mode	90		110	%
$V_{CRS}$	Output signal crossover voltage	Excluding the first transition from idle mode	1.3		2.0	V
Low-Speed Mode						
$t_{LR}$	Rise time	CL=200pF-600pF ; 10 to 90% of $ V_{OH}-V_{OL} $ ;	75		300	ns
$t_{LF}$	Fall time	CL=200pF-600pF ; 90 to 10% of $ V_{OH}-V_{OL} $ ;	75		300	ns
$t_{LRMA}$	Differential rise/fall time matching ( $t_{LR} / t_{LF}$ )	Excluding the first transition from idle mode	80		125	%
$V_{CRS}$	Output signal crossover voltage	Excluding the first transition from idle mode	1.3		2.0	V
$V_{OH}$	High-level output voltage		2.8		3.6	V



## 5.6 Power Switch Feature

AU6375 integrates a 3.3V to 2.5V voltage regulator and power switch to replace all MOS chips for flash card (except CF card) power supply.

### Card Power Output Current Range

- For SD/MMC
  - ◆ MAX: 200mA
- For MS
  - ◆ MAX: 100mA
- For XD/SMC
  - ◆ MAX: 70mA
- For CF
  - ◆ MAX: 250mA
- Card power output voltage range
  - ◆ MS/XD/SD/MMC/SMC/CF:  $3.3V \pm 0.3V$
- AU6375 will turn off all of Card Power in suspend mode

Figure 5.1 Card Detect Power-in Timing

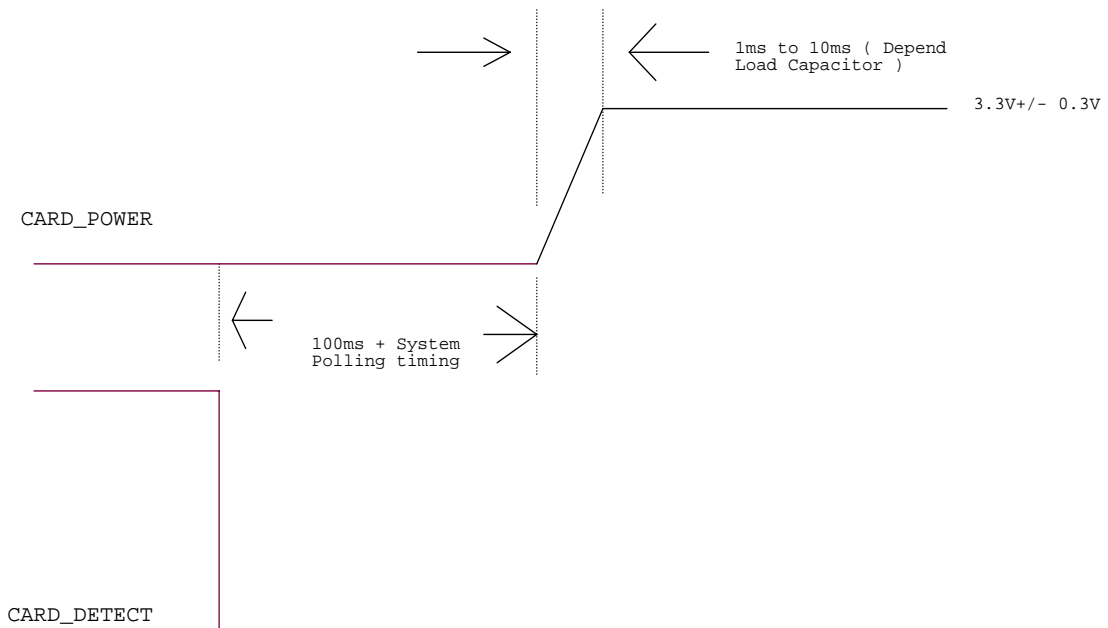



# 6.0 Mechanical Information

Figure 6.1 Mechanical Information Diagram

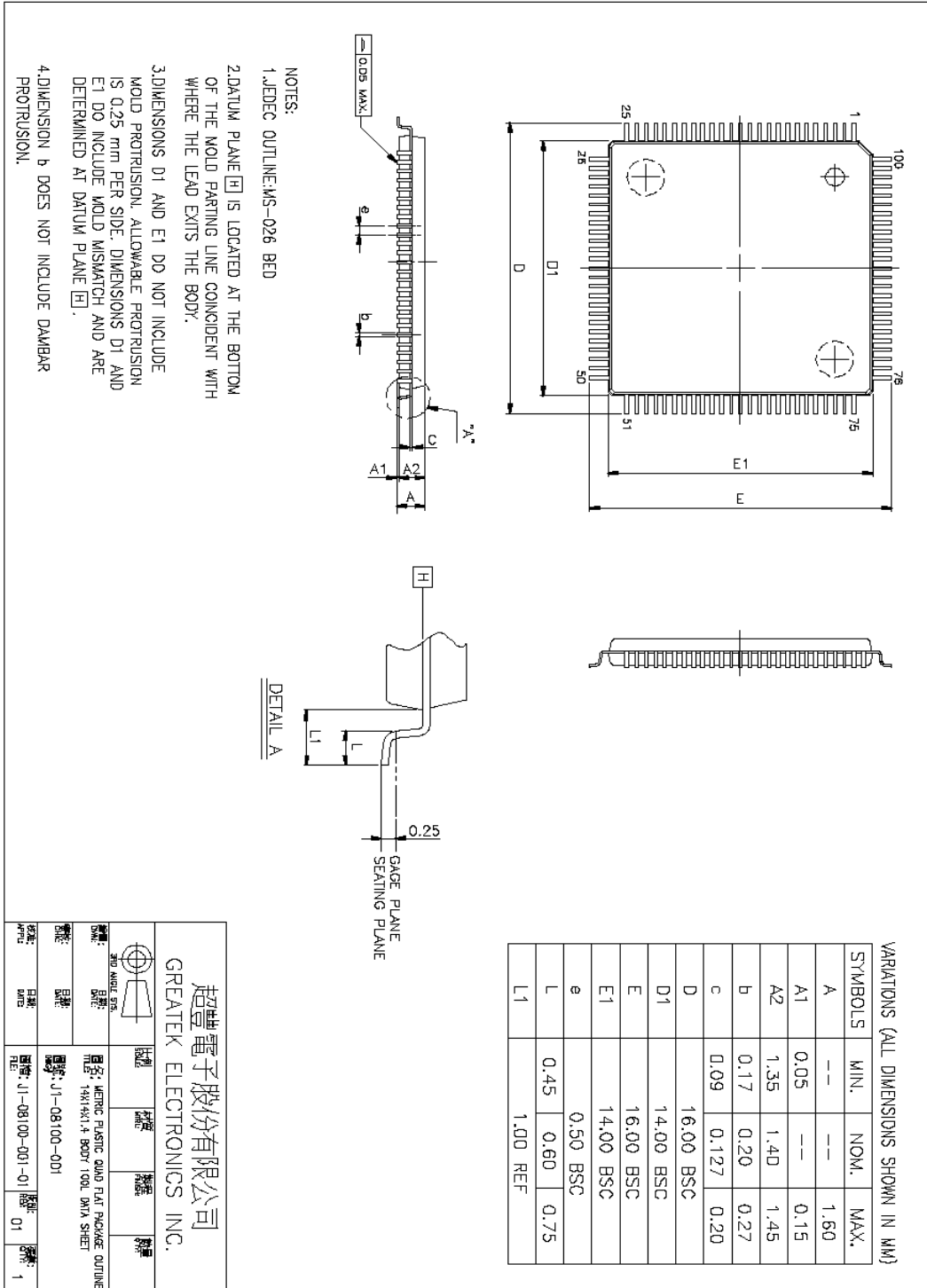



## 7.0 Abbreviations

This chapter lists and defines terms and abbreviations used throughout this specification.

<b>SIE</b>	Serial Interface Engine
<b>CF</b>	Compact Flash
<b>MD</b>	Micro Drive
<b>SMC</b>	SmartMedia Card
<b>MS</b>	Memory Stick
<b>SD</b>	Secure Digital
<b>MMC</b>	Multimedia Card
<b>UTMI</b>	USB Transceiver Macrocell Interface



**Alcor Micro Corp.**

**【MEMO】**

### **About Alcor Micro, Corp**

Alcor Micro, Corp. designs, develops and markets highly integrated and advanced peripheral semiconductor, and software driver solutions for the personal computer and consumer electronics markets worldwide. We specialize in USB solutions and focus on emerging technology such as USB and IEEE 1394. The company offers a range of semiconductors including controllers for USB hub, integrated keyboard/USB hub and USB Flash memory card reader...etc. Alcor Micro, Corp. is based in Taipei, Taiwan, with sales offices in Taipei, Japan, Korea and California.

Alcor Micro is distinguished by its ability to provide innovative solutions for spec-driven products. Innovations like single chip solutions for traditional multiple chip products and on-board voltage regulators enable the company to provide cost-efficiency solutions for the computer peripheral device OEM customers worldwide.