

## DMOS Microstepping Driver with Translator

### Features and Benefits

- Low  $R_{DS(ON)}$  outputs
- Automatic current decay mode detection/selection
- Mixed and Slow current decay modes
- Synchronous rectification for low power dissipation
- Internal UVLO
- Crossover-current protection
- 3.3 and 5 V compatible logic supply
- Very thin profile QFN package
- Thermal shutdown circuitry

Package: 28-pin QFN (suffix ET)

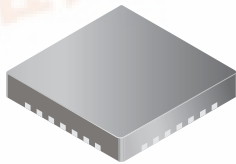

Approximate size



### Description

The A4983 is a complete microstepping motor driver with built-in translator for easy operation. It is designed to operate bipolar stepper motors in full-, half-, quarter-, eighth-, and sixteenth-step modes, with an output drive capacity of up to 35 V and  $\pm 2$  A. The A4983 includes a fixed off-time current regulator which has the ability to operate in Slow or Mixed decay modes.

The translator is the key to the easy implementation of the A4983. Simply inputting one pulse on the STEP input drives the motor one microstep. There are no phase sequence tables, high frequency control lines, or complex interfaces to program. The A4983 interface is an ideal fit for applications where a complex microprocessor is unavailable or is overburdened.

The chopping control in the A4983 automatically selects the current decay mode (Slow or Mixed). When a signal occurs at the STEP input pin, the A4983 determines if that step results in a higher or lower current in each of the motor phases. If the change is to a higher current, then the decay mode is set to Slow decay. If the change is to a lower current, then the current decay is set to Mixed (set initially to a fast decay for a period amounting to 31.25% of the fixed off-time, then to a

*Continued on the next page...*

### Typical Application Diagram

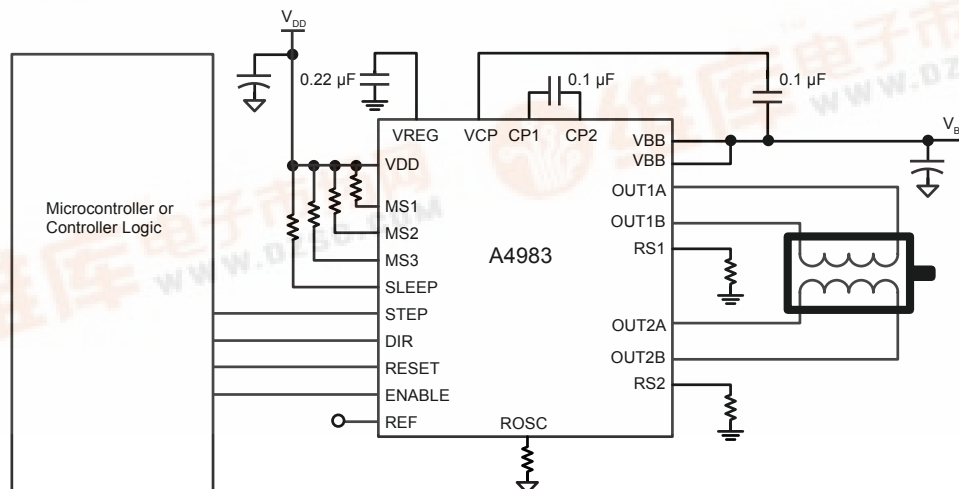

# A4983

# DMOS Microstepping Driver with Translator

## Description (continued)

slow decay for the remainder of the off-time). This current decay control scheme results in reduced audible motor noise, increased step accuracy, and reduced power dissipation.

Internal synchronous rectification control circuitry is provided to improve power dissipation during PWM operation. Internal circuit protection includes: thermal shutdown with hysteresis, undervoltage

lockout (UVLO), and crossover-current protection. Special power-on sequencing is not required.

The A4983 is supplied in a 5 mm × 5 mm × 0.90 nominal surface mount QFN package with exposed thermal pad (suffix ET). The package is lead (Pb) free (suffix -T), with 100% matte tin plated leadframe.

## Selection Guide

Part Number	Pb-free	Package	Packing
A4983SET-T	Yes	28-pin QFN with exposed thermal pad	73 pieces per tube
A4983SETTR-T	Yes	28-pin QFN with exposed thermal pad	1500 pieces per 7-in. reel

## Absolute Maximum Ratings

Characteristic	Symbol	Notes	Rating	Units
Load Supply Voltage	$V_{BB}$		35	V
Output Current	$I_{OUT}$		±2	A
		Duty Cycle < 20%	±2.5	A
Logic Input Voltage	$V_{IN}$		-0.3 to 7	V
Sense Voltage	$V_{SENSE}$		0.5	V
Reference Voltage	$V_{REF}$		4	V
Operating Ambient Temperature	$T_A$	Range S	-20 to 85	°C
Maximum Junction	$T_{J(max)}$		150	°C
Storage Temperature	$T_{stg}$		-55 to 150	°C

Functional Block Diagram

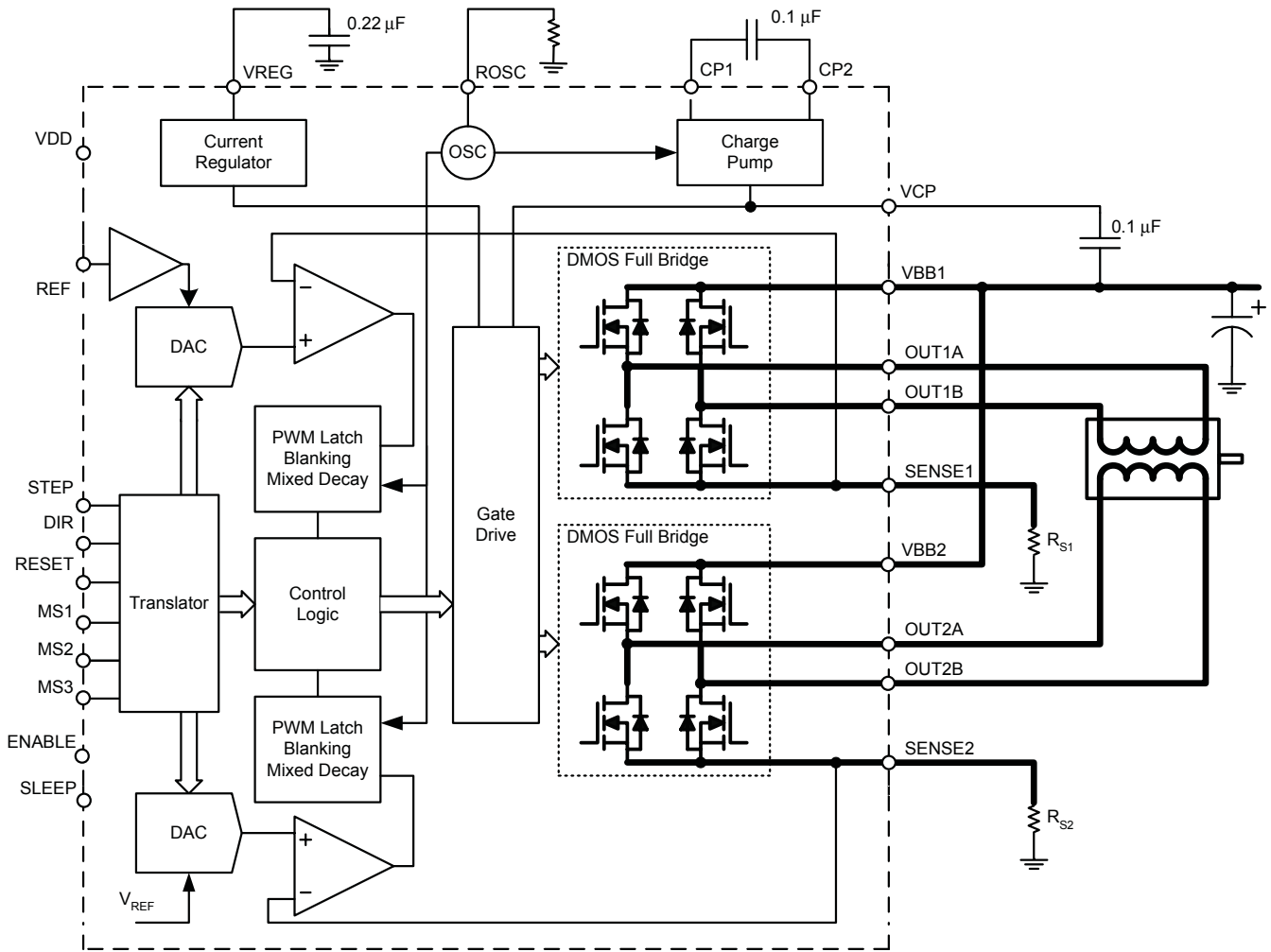

**ELECTRICAL CHARACTERISTICS<sup>1</sup>** at  $T_A = 25^\circ\text{C}$ ,  $V_{BB} = 35\text{ V}$  (unless otherwise noted)

Characteristics	Symbol	Test Conditions	Min.	Typ. <sup>2</sup>	Max.	Units
<b>Output Drivers</b>						
Load Supply Voltage Range	$V_{BB}$	Operating	8	–	35	V
		During Sleep Mode	0	–	35	V
Logic Supply Voltage Range	$V_{DD}$	Operating	3.0	–	5.5	V
Output On Resistance	$R_{DSON}$	Source Driver, $I_{OUT} = -1.5\text{ A}$	–	0.350	0.450	$\Omega$
		Sink Driver, $I_{OUT} = 1.5\text{ A}$	–	0.300	0.370	$\Omega$
Body Diode Forward Voltage	$V_F$	Source Diode, $I_F = -1.5\text{ A}$	–	–	1.2	V
		Sink Diode, $I_F = 1.5\text{ A}$	–	–	1.2	V
Motor Supply Current	$I_{BB}$	$f_{PWM} < 50\text{ kHz}$	–	–	4	mA
		Operating, outputs disabled	–	–	2	mA
		Sleep Mode	–	–	10	$\mu\text{A}$
Logic Supply Current	$I_{DD}$	$f_{PWM} < 50\text{ kHz}$	–	–	8	mA
		Outputs off	–	–	5	mA
		Sleep Mode	–	–	10	$\mu\text{A}$
<b>Control Logic</b>						
Logic Input Voltage	$V_{IN(1)}$		$V_{DD} \times 0.7$	–	–	V
	$V_{IN(0)}$		–	–	$V_{DD} \times 0.3$	V
Logic Input Current	$I_{IN(1)}$	$V_{IN} = V_{DD} \times 0.7$	–20	<1.0	20	$\mu\text{A}$
	$I_{IN(0)}$	$V_{IN} = V_{DD} \times 0.3$	–20	<1.0	20	$\mu\text{A}$
Microstep Select 2	$R_{MS2}$		–	100	–	k $\Omega$
Microstep Select 3	$R_{MS3}$		–	100	–	k $\Omega$
Input Hysteresis	$V_{HYS(IN)}$		150	300	500	mV
Blank Time	$t_{BLANK}$		0.7	1	1.3	$\mu\text{s}$
Fixed Off-Time	$t_{OFF}$	OSC > 3 V	20	30	40	$\mu\text{s}$
		$R_{OSC} = 25\text{ k}\Omega$	23	30	37	$\mu\text{s}$
Reference Input Voltage Range	$V_{REF}$		0	–	4	V
Reference Input Current	$I_{REF}$		–3	0	3	$\mu\text{A}$
Current Trip-Level Error <sup>3</sup>	$err_I$	$V_{REF} = 2\text{ V}$ , % $I_{TripMAX} = 38.27\%$	–	–	$\pm 15$	%
		$V_{REF} = 2\text{ V}$ , % $I_{TripMAX} = 70.71\%$	–	–	$\pm 5$	%
		$V_{REF} = 2\text{ V}$ , % $I_{TripMAX} = 100.00\%$	–	–	$\pm 5$	%
Crossover Dead Time	$t_{DT}$		100	475	800	ns
<b>Protection</b>						
Thermal Shutdown Temperature	$T_J$		–	165	–	$^\circ\text{C}$
Thermal Shutdown Hysteresis	$T_{JHYS}$		–	15	–	$^\circ\text{C}$
UVLO Enable Threshold	$UV_{LO}$	$V_{DD}$ rising	2.35	2.7	3	V
UVLO Hysteresis	$UV_{HYS}$		0.05	0.10	–	V

<sup>1</sup>Negative current is defined as coming out of (sourcing from) the specified device pin.<sup>2</sup>Typical data are for initial design estimations only, and assume optimum manufacturing and application conditions. Performance may vary for individual units, within the specified maximum and minimum limits.<sup>3</sup> $err_I = (I_{Trip} - I_{Prog}) / I_{Prog}$ , where  $I_{Prog} = \%I_{TripMAX} \times I_{TripMAX}$ .

**THERMAL CHARACTERISTICS may require derating at maximum conditions**

Characteristic	Symbol	Test Conditions*	Value	Units
Package Thermal Resistance	$R_{\theta JA}$	Package ET; 4-layer PCB, based on JEDEC standard	32	$^{\circ}\text{C}/\text{W}$

\*In still air. Additional thermal information available on Allegro Web site.

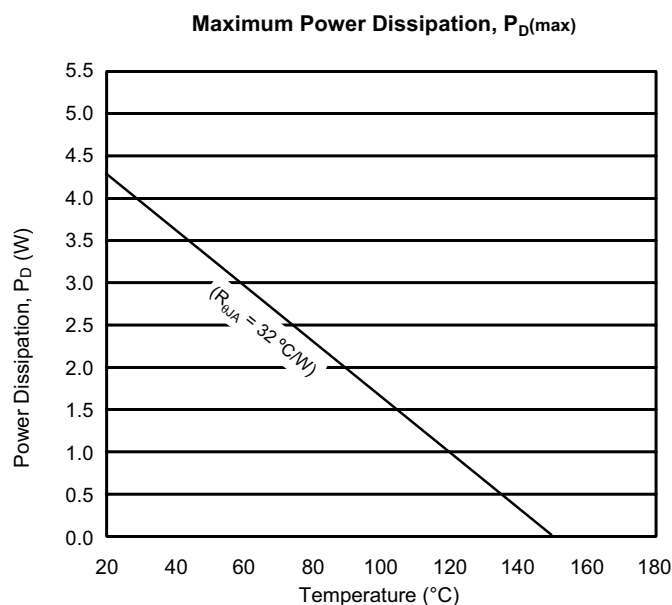

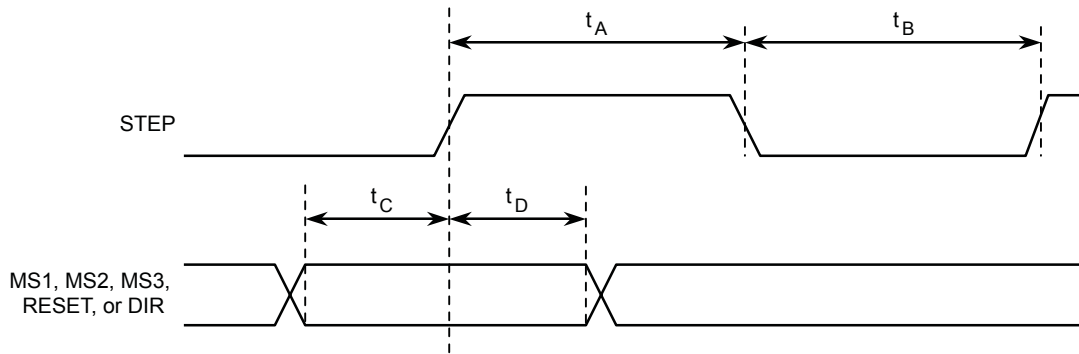

Time Duration	Symbol	Typ.	Unit
STEP minimum, HIGH pulse width	$t_A$	1	$\mu\text{s}$
STEP minimum, LOW pulse width	$t_B$	1	$\mu\text{s}$
Setup time, input change to STEP	$t_C$	200	ns
Hold time, input change to STEP	$t_D$	200	ns

Figure 1. Logic Interface Timing Diagram

Table 1. Microstep Resolution Truth Table

MS1	MS2	MS3	Microstep Resolution	Excitation Mode
L	L	L	Full Step	2 Phase
H	L	L	Half Step	1-2 Phase
L	H	L	Quarter Step	W1-2 Phase
H	H	L	Eighth Step	2W1-2 Phase
H	H	H	Sixteenth Step	4W1-2 Phase

## Functional Description

**Device Operation.** The A4983 is a complete microstepping motor driver with a built-in translator for easy operation with minimal control lines. It is designed to operate bipolar stepper motors in full-, half-, quarter-, and sixteenth-step modes. The currents in each of the two output full-bridges and all of the N-channel DMOS FETs are regulated with fixed off-time PWM (pulse width modulated) control circuitry. At each step, the current for each full-bridge is set by the value of its external current-sense resistor ( $R_{S1}$  and  $R_{S2}$ ), a reference voltage ( $V_{REF}$ ), and the output voltage of its DAC (which in turn is controlled by the output of the translator).

At power-on or reset, the translator sets the DACs and the phase current polarity to the initial Home state (shown in figures 2 through 6), and the current regulator to Mixed Decay Mode for both phases. When a step command signal occurs on the STEP input, the translator automatically sequences the DACs to the next level and current polarity. (See table 2 for the current-level sequence.) The microstep resolution is set by the combined effect of inputs MS1, MS2, and MS3, as shown in table 1.

When stepping, if the new output levels of the DACs are lower than their previous output levels, then the decay mode for the active full-bridge is set to Mixed. If the new output levels of the DACs are higher than or equal to their previous levels, then the decay mode for the active full-bridge is set to Slow. This automatic current decay selection improves microstepping performance by reducing the distortion of the current waveform that results from the back EMF of the motor.

If the logic circuits are pulled up to  $V_{DD}$ , it is good practice to use a high value pull-up resistor in order to limit current to the logic inputs, should an overvoltage event occur. Logic inputs include: MSx, SLEEP, DIR, ENABLE, RESET, and STEP.

**RESET Input (RESET).** The RESET input sets the translator to a predefined Home state (shown in figures 2 through 6), and turns off all of the FET outputs. All STEP inputs are ignored until the RESET input is set to high.

**Step Input (STEP).** A low-to-high transition on the STEP input sequences the translator and advances the motor one increment. The translator controls the input to the DACs and the direction of current flow in each winding. The size of the increment is determined by the combined state of inputs MS1, MS2, and MS3.

**Microstep Select (MS1, MS2, and MS3).** Selects the microstepping format, as shown in table 1. MS2 and MS3 have a 100 k $\Omega$  pull-down resistance. Any changes made to these inputs do not take effect until the next STEP rising edge.

If the MSx pins are pulled up to  $V_{DD}$ , it is good practice to use a high value pull-up resistor in order to limit current to these pins, should an overvoltage event occur.

**Direction Input (DIR).** This determines the direction of rotation of the motor. When low, the direction will be clockwise and when high, counterclockwise. Changes to this input do not take effect until the next STEP rising edge.

**Internal PWM Current Control.** Each full-bridge is controlled by a fixed off-time PWM current control circuit that limits the load current to a desired value,  $I_{TRIP}$ . Initially, a diagonal pair of source and sink FET outputs are enabled and current flows through the motor winding and the current sense resistor,  $R_{Sx}$ . When the voltage across  $R_{Sx}$  equals the DAC output voltage, the current sense comparator resets the PWM latch. The latch then turns off either the source FETs (when in Slow Decay Mode) or the sink and source FETs (when in Mixed Decay Mode).

The maximum value of current limiting is set by the selection of  $R_{Sx}$  and the voltage at the VREF pin. The transconductance function is approximated by the maximum value of current limiting,  $I_{TRIPMAX}$  (A), which is set by

$$I_{TRIPMAX} = V_{REF} / (8 \times R_S)$$

where  $R_S$  is the resistance of the sense resistor ( $\Omega$ ) and  $V_{REF}$  is the input voltage on the REF pin (V).

The DAC output reduces the  $V_{REF}$  output to the current sense comparator in precise steps, such that

$$I_{trip} = (\%I_{TRIPMAX} / 100) \times I_{TRIPMAX}$$

(See table 2 for  $\%I_{TRIPMAX}$  at each step.)

It is critical that the maximum rating (0.5 V) on the SENSE1 and SENSE2 pins is not exceeded.

**Fixed Off-Time.** The internal PWM current control circuitry uses a one-shot circuit to control the duration of time that the DMOS FETs remain off. The one shot off-time,  $t_{OFF}$ , is determined by the selection of an external resistor connected from the ROSC timing pin to ground. If the ROSC pin is tied to an external voltage  $> 3$  V, then  $t_{OFF}$  defaults to 30  $\mu$ s. The ROSC pin can be safely connected to the VDD pin for this purpose. The value of  $t_{OFF}$  ( $\mu$ s) is approximately

$$t_{OFF} \approx R_{OSC} / 825$$

**Blanking.** This function blanks the output of the current sense comparators when the outputs are switched by the internal current control circuitry. The comparator outputs are blanked to prevent false overcurrent detection due to reverse recovery currents of the clamp diodes, and switching transients related to the capacitance of the load. The blank time,  $t_{BLANK}$  ( $\mu$ s), is approximately

$$t_{BLANK} \approx 1 \mu\text{s}$$

**Charge Pump (CP1 and CP2).** The charge pump is used to generate a gate supply greater than that of VBB for driving the source-side FET gates. A 0.1  $\mu$ F ceramic capacitor, should be connected between CP1 and CP2. In addition, a 0.1  $\mu$ F ceramic capacitor is required between VCP and VBB, to act as a reservoir for operating the high-side FET gates.

**VREG (VREG).** This internally-generated voltage is used to operate the sink-side FET outputs. The VREG pin must be decoupled with a 0.22  $\mu$ F ceramic capacitor to ground. VREG is internally monitored. In the case of a fault condition, the FET outputs of the A4983 are disabled.

**Enable Input (ENABLE).** This input turns on or off all of the FET outputs. When set to a logic high, the outputs are disabled. When set to a logic low, the internal control enables the outputs as required. The translator inputs STEP, DIR, MS1, MS2, and MS3, as well as the internal sequencing logic, all remain active, independent of the ENABLE input state.

**Shutdown.** In the event of a fault, overtemperature (excess  $T_J$ ) or an undervoltage (on VCP), the FET outputs of the A4983 are disabled until the fault condition is removed. At power-on, the UVLO (undervoltage lockout) circuit disables the FET outputs and resets the translator to the Home state.

**Sleep Mode (SLEEP).** To minimize power consumption when the motor is not in use, this input disables much of the internal circuitry including the output FETs, current regulator, and charge pump. A logic low on the SLEEP pin puts the A4983 into Sleep mode. A logic high allows normal operation, as well as start-up (at which time the A4983 drives the motor to the Home microstep position). When emerging from Sleep mode, in order to allow the charge pump to stabilize, provide a delay of 1 ms before issuing a Step command.

If the SLEEP pin is pulled up to  $V_{DD}$ , it is good practice to use a high value pull-up resistor in order to limit current to the pin, should an overvoltage event occur.

**Mixed Decay Operation.** The bridge can operate in Mixed Decay mode, depending on the step sequence, as shown in figures 3 through 6. As the trip point is reached, the A4983 initially goes into a fast decay mode for 31.25% of the off-time,  $t_{OFF}$ . After that, it switches to Slow Decay mode for the remainder of  $t_{OFF}$ . A timing diagram for this feature appears on the next page.

**Synchronous Rectification.** When a PWM-off cycle is triggered by an internal fixed-off-time cycle, load current recirculates according to the decay mode selected by the control logic. This synchronous rectification feature turns on the appropriate FETs during current decay, and effectively shorts out the body diodes with the low FET  $R_{DS(ON)}$ . This reduces power dissipation significantly, and can eliminate the need for external Schottky diodes in many applications. Synchronous rectification turns off when the load current approaches zero (0 A), preventing reversal of the load current. A timing diagram for this feature appears on the next page.



Current Decay Modes Timing Chart

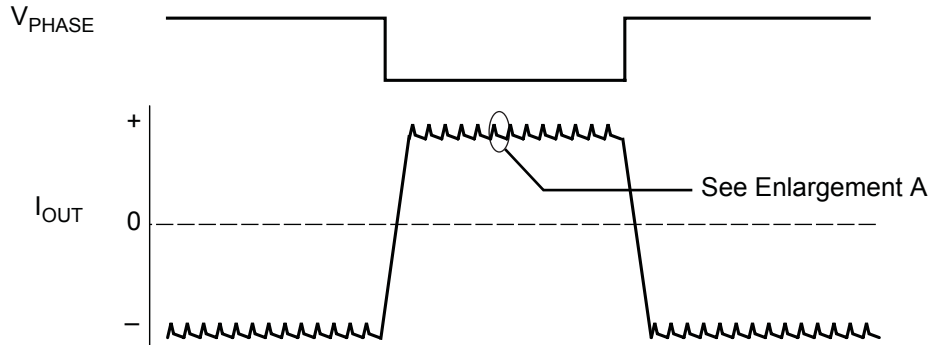

Enlargement A

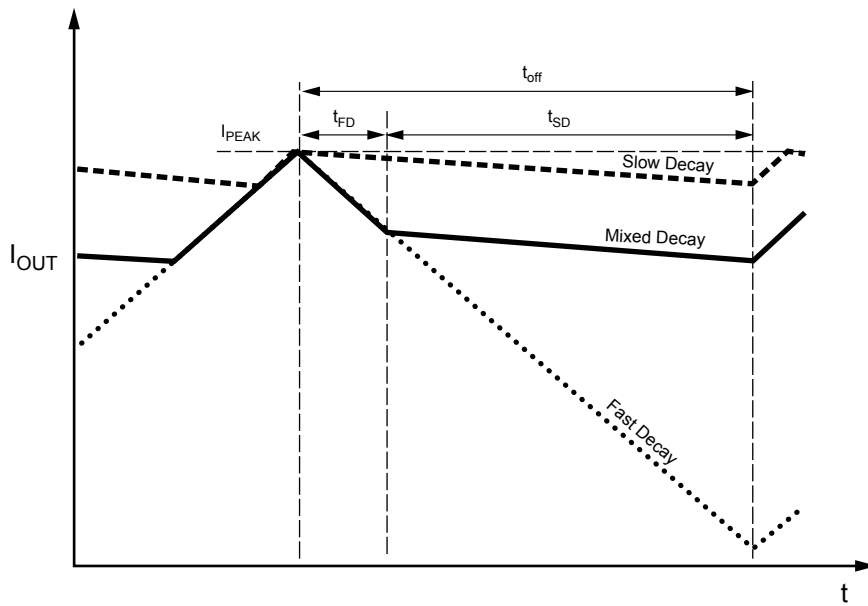

Symbol	Characteristic
$t_{off}$	Device fixed off-time
$I_{PEAK}$	Maximum output current
$t_{SD}$	Slow decay interval
$t_{FD}$	Fast decay interval
$I_{OUT}$	Device output current

Application Layout

**Layout** The printed circuit board should use a heavy ground-plane. For optimum electrical and thermal performance, the A4983 must be soldered directly onto the board. On the underside of the A4983 package is an exposed pad, which provides a path for enhanced thermal dissipation. The thermal pad should be soldered directly to an exposed surface on the PCB. Thermal vias are used to transfer heat to other layers of the PCB. Thermal vias should not have any thermal relief and should be connected to internal layers, if available, to maximize the dissipation area.

**Grounding** In order to minimize the effects of ground bounce and offset issues, it is important to have a low impedance single-point ground, known as a *star ground*, located very close to the device. By making the connection between the exposed thermal pad and the groundplane directly under the A4983, that area becomes an ideal location for a star ground point.

A low impedance ground will prevent ground bounce during high current operation and ensure that the supply voltage remains stable at the input terminal. The recommended PCB layout shown in the diagram below, illustrates how to create a star ground under the device, to serve both as low impedance ground point and thermal path.

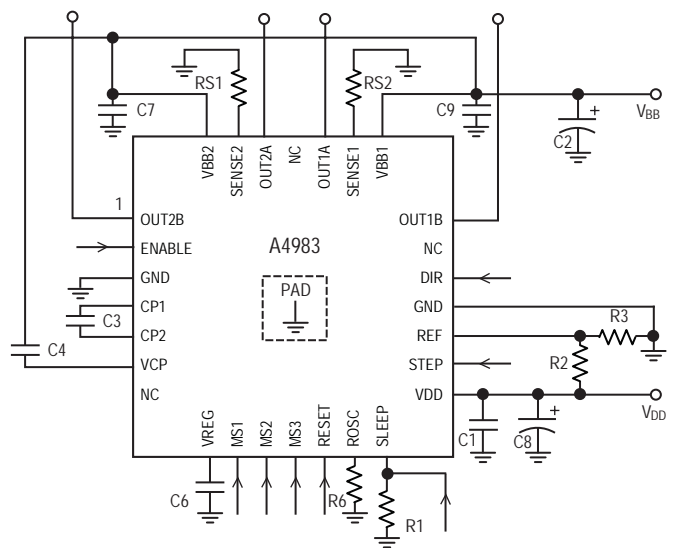
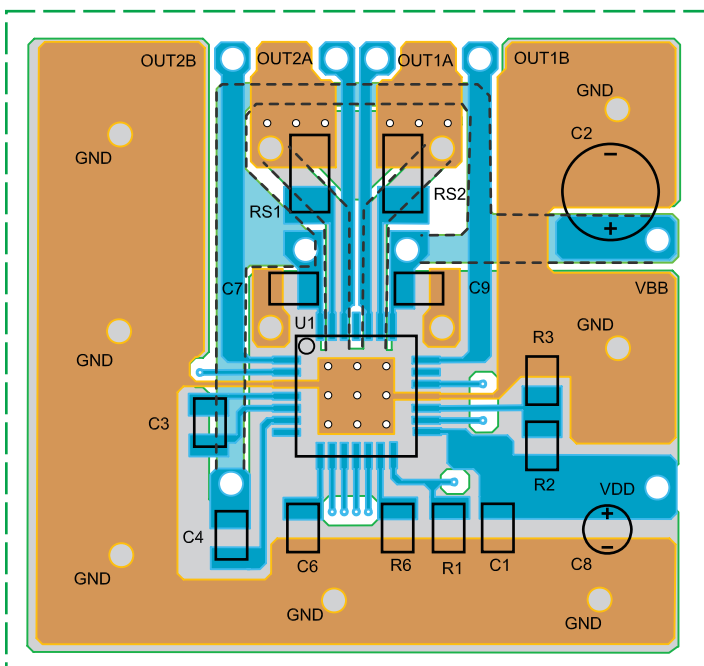
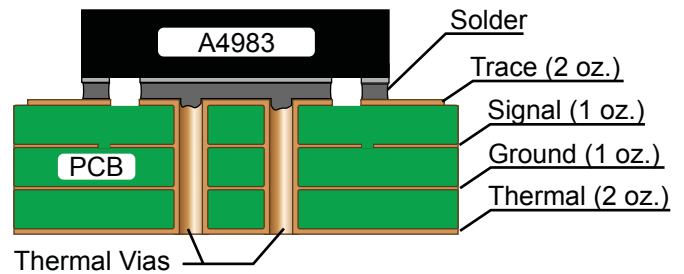

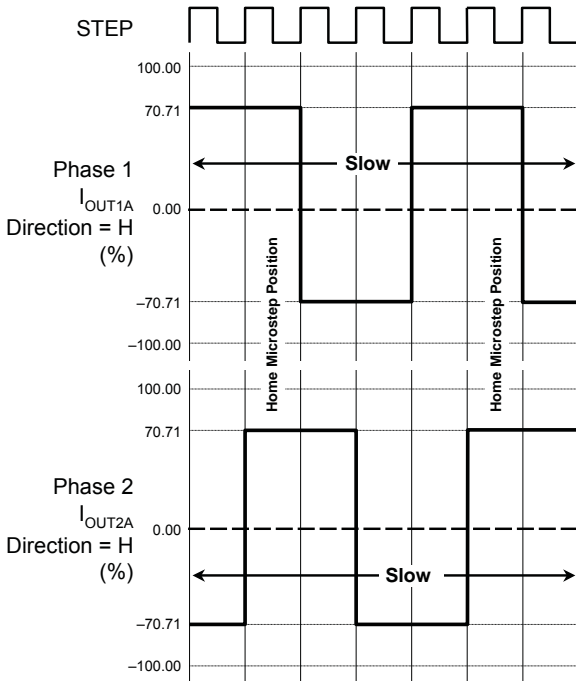

Figure 2. Decay Mode for Full-Step Increments

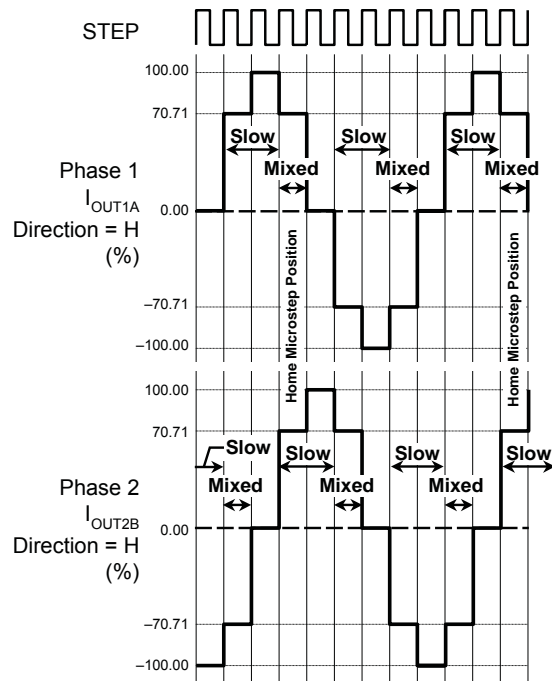

Figure 3. Decay Modes for Half-Step Increments

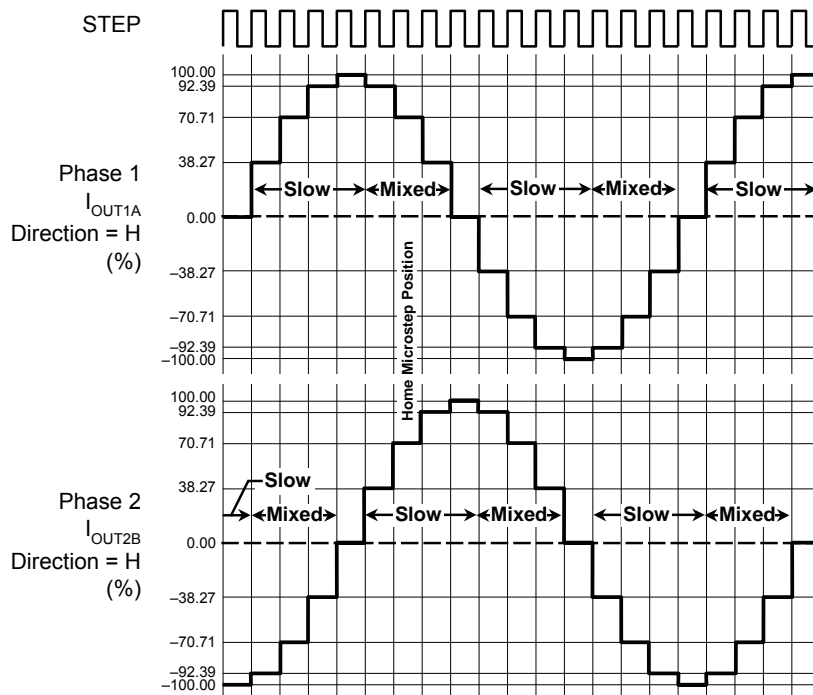

Figure 4. Decay Modes for Quarter-Step Increments

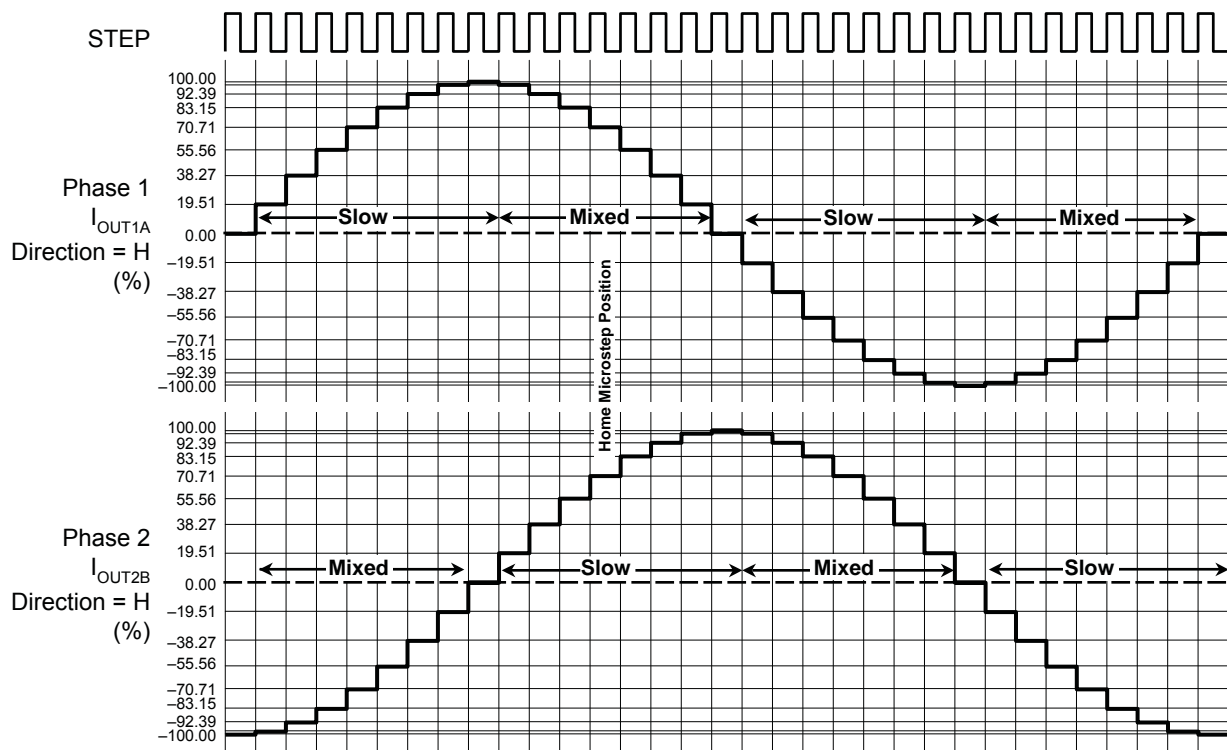

Figure 5. Decay Modes for Eighth-Step Increments

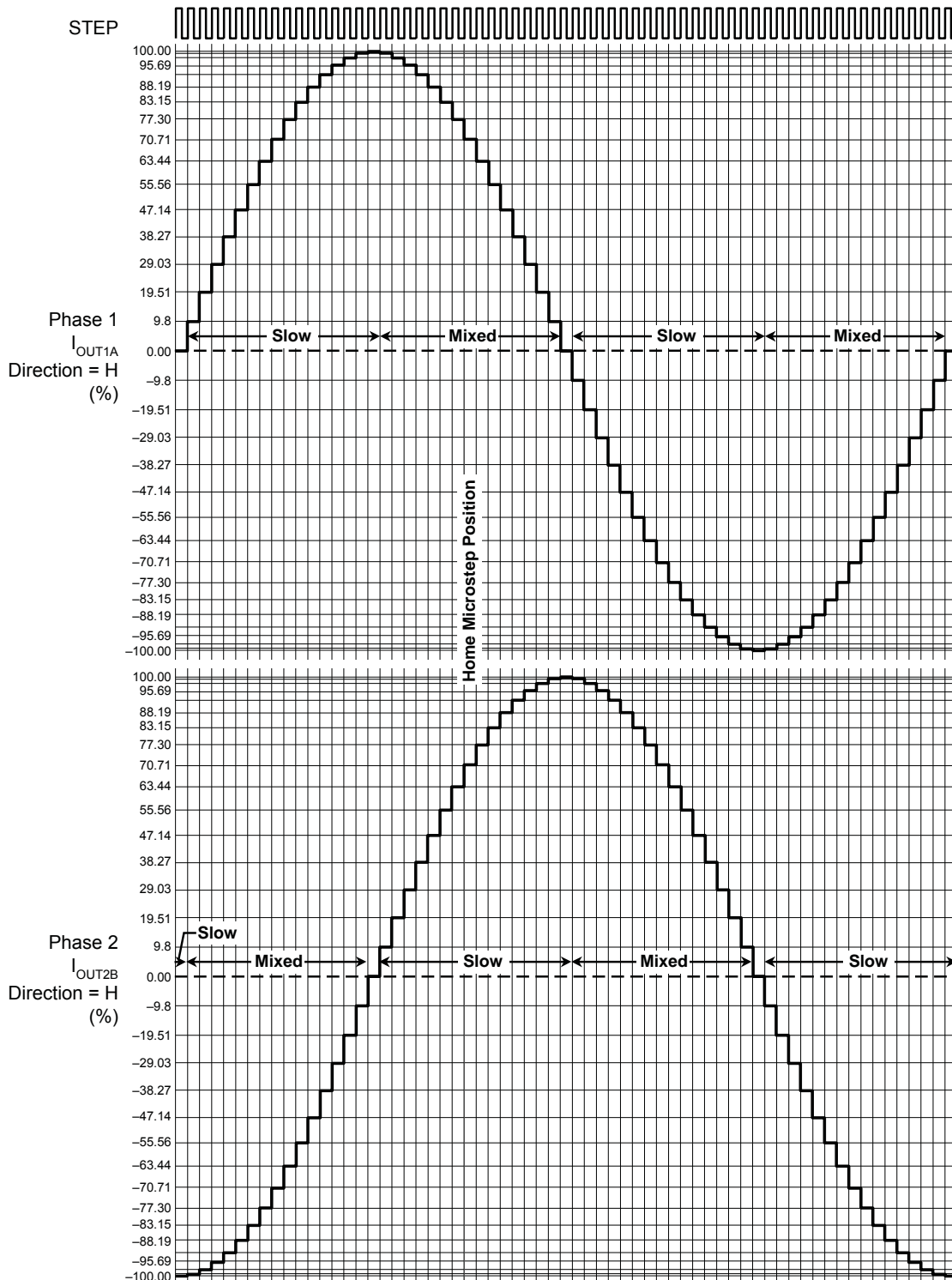

Figure 6. Decay Modes for Sixteenth-Step Increments

# A4983

# DMOS Microstepping Driver with Translator

Table 2. Step Sequencing Settings  
Home microstep position at Step Angle 45°; DIR = H

Full Step #	Half Step #	1/4 Step #	1/8 Step #	1/16 Step #	Phase 1 Current [% I <sub>tripMax</sub> ] (%)	Phase 2 Current [% I <sub>tripMax</sub> ] (%)	Step Angle (°)	Full Step #	Half Step #	1/4 Step #	1/8 Step #	1/16 Step #	Phase 1 Current [% I <sub>tripMax</sub> ] (%)	Phase 2 Current [% I <sub>tripMax</sub> ] (%)	Step Angle (°)	
	1	1	1	1	100.00	0.00	0.0									
				2	99.52	9.80	5.6		5	9	17	33	-100.00	0.00	180.0	
				3	98.08	19.51	11.3					34	-99.52	-9.80	185.6	
			2	4	95.69	29.03	16.9				18	35	-98.08	-19.51	191.3	
				5	92.39	38.27	22.5					36	-95.69	-29.03	196.9	
		2	3	6	88.19	47.14	28.1			10	19	37	-92.39	-38.27	202.5	
				7	83.15	55.56	33.8					38	-88.19	-47.14	208.1	
			4	8	77.30	63.44	39.4				20	39	-83.15	-55.56	213.8	
				9	70.71	70.71	45.0					40	-77.30	-63.44	219.4	
1	2	3	5	10	63.44	77.30	50.6	3	6	11	21	41	-70.71	-70.71	225.0	
				11	55.56	83.15	56.3					42	-63.44	-77.30	230.6	
				12	47.14	88.19	61.9					22	43	-55.56	-83.15	236.3
				13	38.27	92.39	67.5					44	-47.14	-88.19	241.9	
		4	7	14	29.03	95.69	73.1			12	23	45	-38.27	-92.39	247.5	
				15	19.51	98.08	78.8					46	-29.03	-95.69	253.1	
				16	9.80	99.52	84.4					24	47	-19.51	-98.08	258.8
				17	0.00	100.00	90.0					48	-9.80	-99.52	264.4	
	3	5	9	18	-9.80	99.52	95.6		7	13	25	49	0.00	-100.00	270.0	
				19	-19.51	98.08	101.3					50	9.80	-99.52	275.6	
				20	-29.03	95.69	106.9					26	51	19.51	-98.08	281.3
				21	-38.27	92.39	112.5					52	29.03	-95.69	286.9	
		6	11	22	-47.14	88.19	118.1			14	27	53	38.27	-92.39	292.5	
				23	-55.56	83.15	123.8					54	47.14	-88.19	298.1	
				24	-63.44	77.30	129.4					28	55	55.56	-83.15	303.8
				25	-70.71	70.71	135.0					56	63.44	-77.30	309.4	
2	4	7	13	26	-77.30	63.44	140.6	4	8	15	29	57	70.71	-70.71	315.0	
				27	-83.15	55.56	146.3					58	77.30	-63.44	320.6	
				28	-88.19	47.14	151.9					30	59	83.15	-55.56	326.3
				29	-92.39	38.27	157.5					60	88.19	-47.14	331.9	
		8	15	30	-95.69	29.03	163.1			16	31	61	92.39	-38.27	337.5	
				31	-98.08	19.51	168.8					62	95.69	-29.03	343.1	
				32	-99.52	9.80	174.4					32	63	98.08	-19.51	348.8
												64	99.52	-9.80	354.4	

Pin-out Diagram

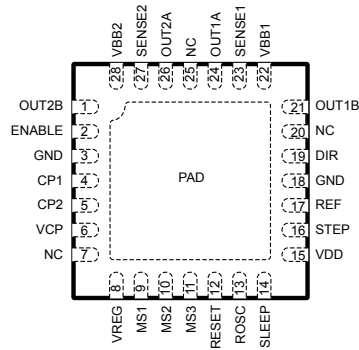



Terminal List Table

Name	Number	Description
CP1	4	Charge pump capacitor terminal
CP2	5	Charge pump capacitor terminal
VCP	6	Reservoir capacitor terminal
VREG	8	Regulator decoupling terminal
MS1	9	Logic input
MS2	10	Logic input
MS3	11	Logic input
RESET	12	Logic input
ROSC	13	Timing set
SLEEP	14	Logic input
VDD	15	Logic supply
STEP	16	Logic input
REF	17	G <sub>m</sub> reference voltage input
GND	3, 18	Ground*
DIR	19	Logic input
OUT1B	21	DMOS Full Bridge 1 Output B
VBB1	22	Load supply
SENSE1	23	Sense resistor terminal for Bridge 1
OUT1A	24	DMOS Full Bridge 1 Output A
OUT2A	26	DMOS Full Bridge 2 Output A
SENSE2	27	Sense resistor terminal for Bridge 2
VBB2	28	Load supply
OUT2B	1	DMOS Full Bridge 2 Output B
ENABLE	2	Logic input
NC	7, 20, 25	No connection
PAD	-	Exposed pad for enhanced thermal dissipation*

\*The GND pins must be tied together externally by connecting to the PAD ground plane under the device.

ET Package, 28-Pin QFN with Exposed Thermal Pad

All dimensions reference, not for tooling use  
 (reference JEDEC MO-220VHHD except contact length and exposed pad length and width)  
 Dimensions in millimeters  
 U.S. Customary dimensions (in.) in brackets, for reference only  
 Dimensions exclusive of mold flash, gate burrs, and dambar protrusions  
 Exact case and lead configuration at supplier discretion within limits shown

-  Terminal #1 mark area
-  Exposed thermal pad (terminal #1 identifier appearance at supplier discretion)
-  Reference land pattern layout (reference IPC7351 QFN50P500X500X100-29V3M) except heel extended: adjust as necessary to meet application process requirements and PCB layout tolerances; when mounting on a multilayer PCB, thermal vias at the exposed thermal pad land can improve thermal dissipation (reference EIA/JEDEC Standard JESD51-5)

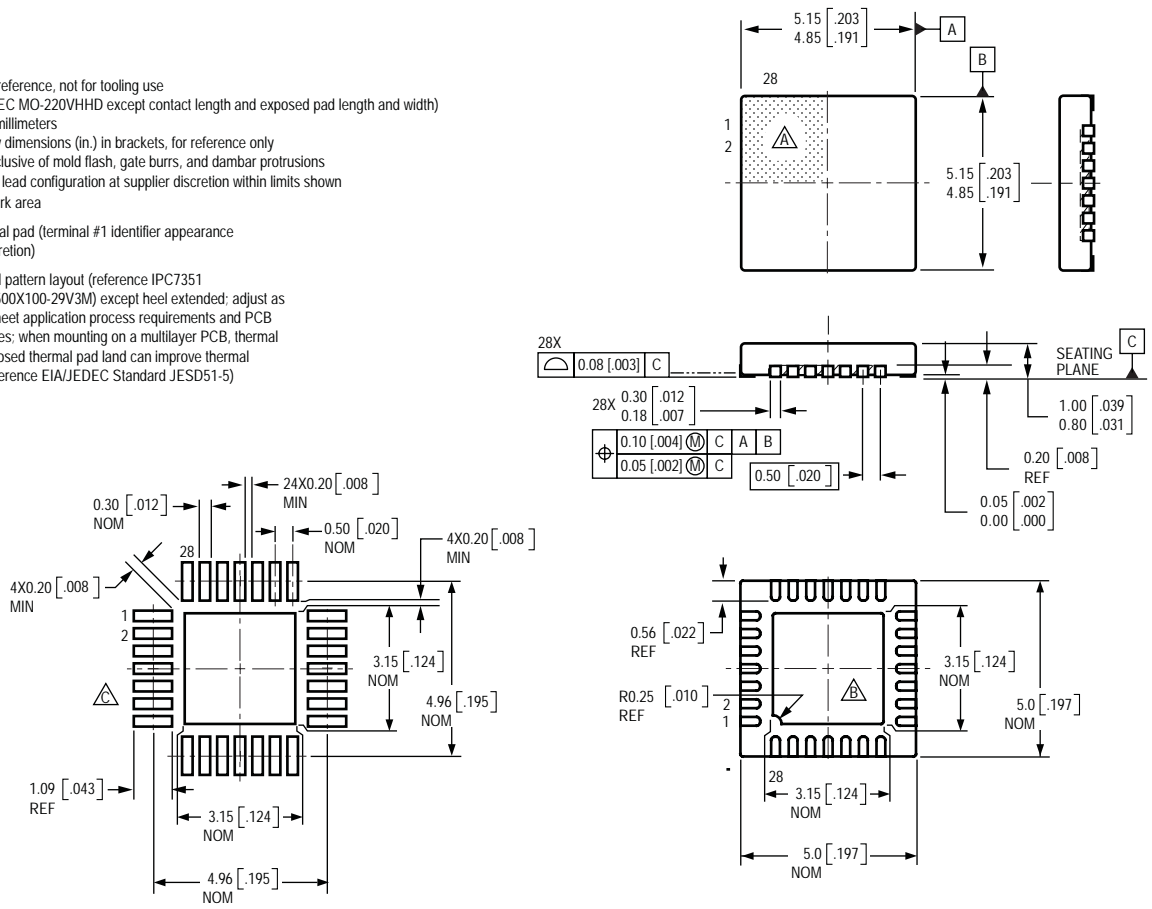

The products described here are manufactured under one or more U.S. patents or U.S. patents pending.

Allegro MicroSystems, Inc. reserves the right to make, from time to time, such departures from the detail specifications as may be required to permit improvements in the performance, reliability, or manufacturability of its products. Before placing an order, the user is cautioned to verify that the information being relied upon is current.

Allegro's products are not to be used in life support devices or systems, if a failure of an Allegro product can reasonably be expected to cause the failure of that life support device or system, or to affect the safety or effectiveness of that device or system. The information included herein is believed to be accurate and reliable. However, Allegro MicroSystems, Inc. assumes no responsibility for its use; nor for any infringement of patents or other rights of third parties which may result from its use.

Copyright ©2007, Allegro MicroSystems, Inc.

For the latest version of this document, visit our website:

[www.allegromicro.com](http://www.allegromicro.com)