



UNISONIC TECHNOLOGIES CO.,

A6225

LINEAR INTEGRATED CIRCUIT

DUAL PRE-AMPLIFIER

■ FEATURES

- * Dual pre amplifier for car or home stereo use.
- * High voltage gain: $G_{VO} = 100\text{dB}$ (Typ.) at $f = 1\text{kHz}$.
- * Excellent channel separation and high ripple rejection
 : $CS = 65\text{dB}$ (Typ.)
 ($f = 10\text{kHz}$, $R_G = 2.2\text{k}\Omega$, $V_{OUT} = 0\text{dBm}$)
 : $RR = 50\text{dB}$ (Typ.)
- * Low noise: $V_{NI} = 1.0\mu\text{V}$ (Typ.) at $R_G = 2.2\text{k}\Omega$, $Bw = 20\text{Hz} \sim 20\text{kHz}$
- * Wide operating supply voltage range: $V_{CC} = 6 \sim 16\text{V}$ ($T_a = 25^\circ\text{C}$)

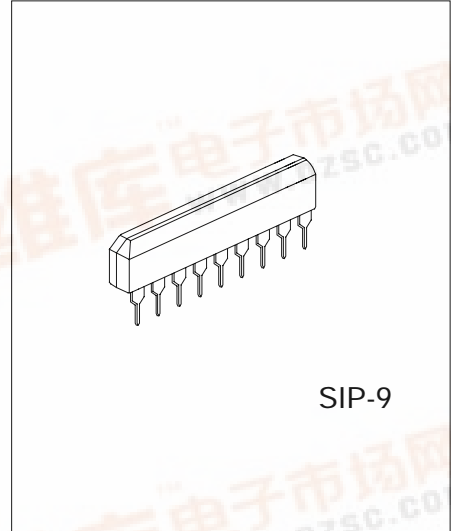

SIP-9

*Pb-free plating product number: A6225L

■ ORDERING INFORMATION

Order Number		Package	Packing
Normal	Lead free		
A6225-G09-T	A6225L-G09-T	SIP-9	Tube



■ ABSOLUTE MAXIMUM RATINGS (Ta = 25)

PARAMETER	SYMBOL	RATINGS	UNIT
Supply Voltage	V _{CC}	16	V
Power Dissipation (Note)	P _D	700	mW
Operating Temperature	T _{OPR}	0 ~ +70	
Storage Temperature	T _{STG}	-40 ~ +150	

Note 1. Derated above Ta = 25 in the Proportion of 5.6mW/

- Absolute maximum ratings are stress ratings only and functional device operation is not implied. The device could be damaged beyond Absolute maximum ratings.
- The device is guaranteed to meet performance specifications within 0 ~70 operating temperature range and assured by design from -20 ~85 .

■ ELECTRICAL CHARACTERISTICS

(Ta=25 , V_{CC} 6V, R_G=600Ω, R_L=10kΩ, f=1kHz, unless otherwise specified.)

PARAMETER	SYMBOL	TEST CONDITIONS	MIN	TYP	MAX	UNIT
Supply Current	I _{CC}	V _{IN} = 0V		3	6	mA
Voltage Gain	OPEN	G _{VO} V _{OUT} = 0dBm	75	100		dB
	CLOSED	G _{VC} V _{OUT} = 0dBm	38.5	41.5	44.5	
Maximum Output Voltage	V _{O(MAX)}	THD = 1%	1.0	1.8		V
Equivalent Input Noise Voltage	V _{IN(INO)}	R _G = 2.2kΩ, BPF = 20Hz ~ 20kHz		1.0	1.7	μV
Input Resistance	R _{IN}		50	150		kΩ
Channel Separation	CS	f = 10kHz, V _{OUT} = 0dBm		65		dB
Ripple Rejection	RR	f = 10kHz, R _G = 2.2kΩ		50		dB
Total Harmonic Distortion	THD	V _{OUT} = 0dBm		0.04	0.25	%

A6225

LINEAR INTEGRATED CIRCUIT

■ TEST CIRCUIT

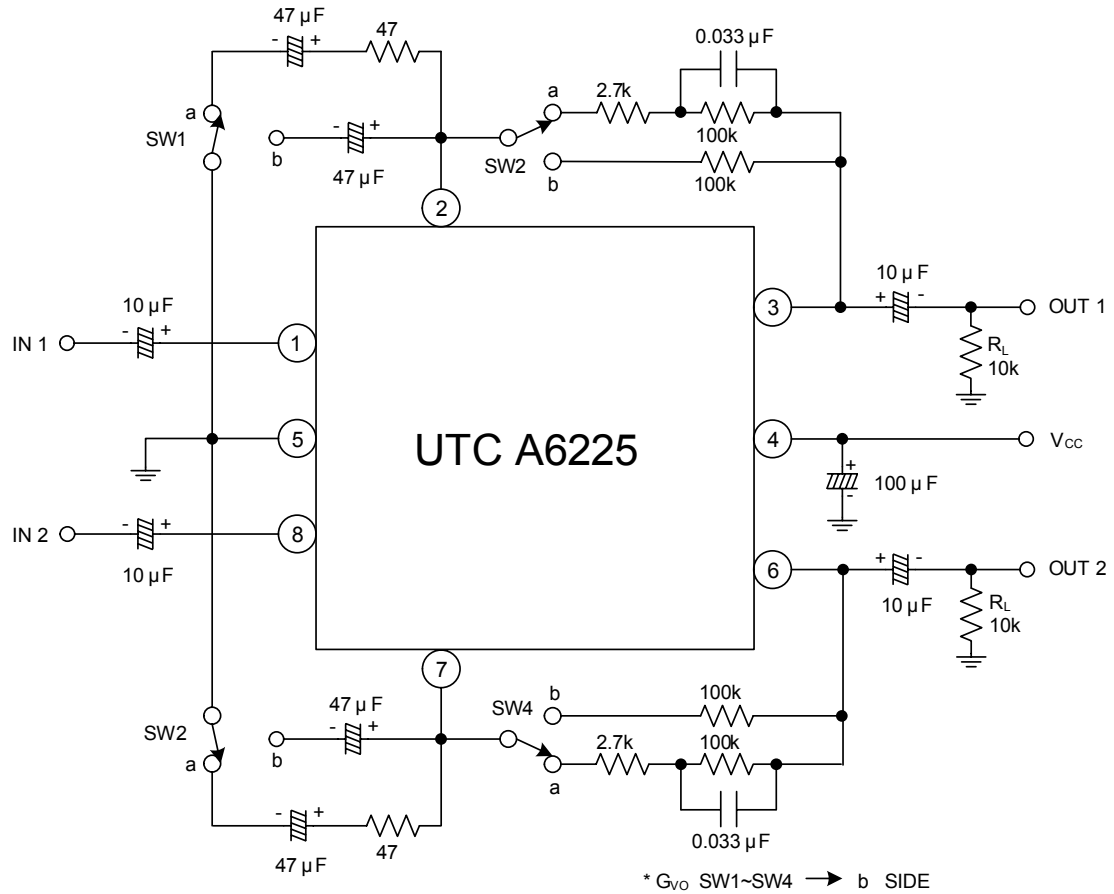

■ TYPICAL APPLICATION CIRCUIT

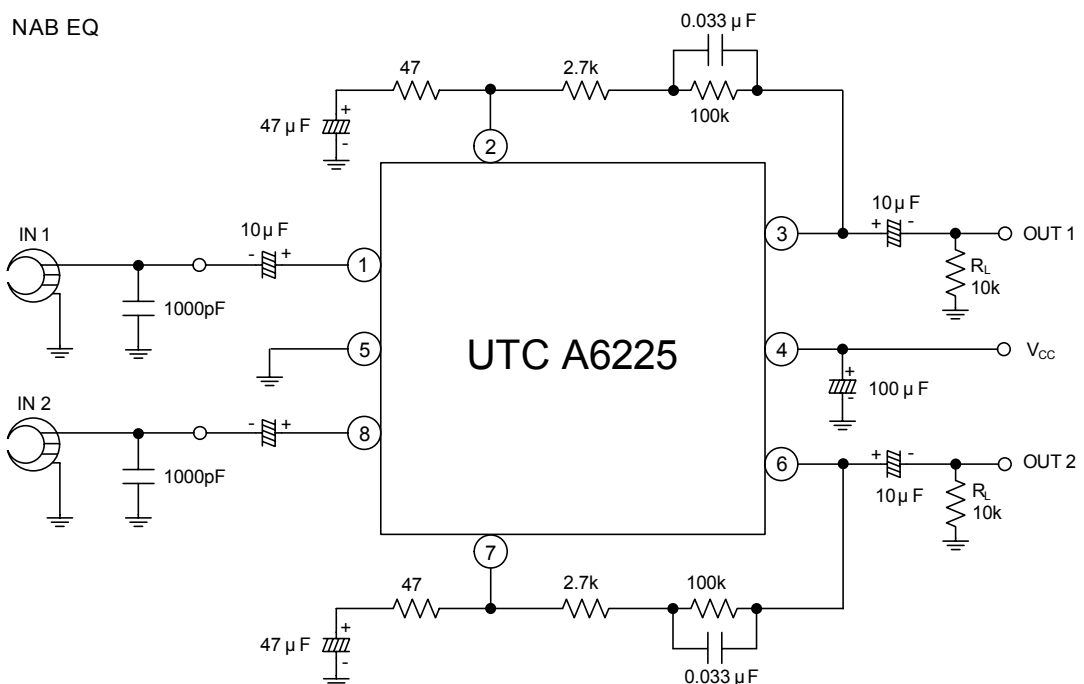

■ TYPICAL CHARACTERISTICS

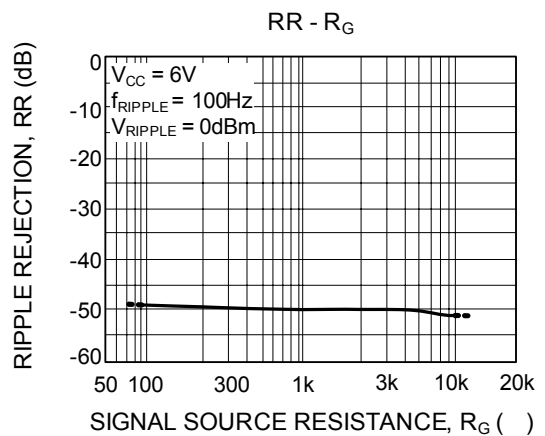
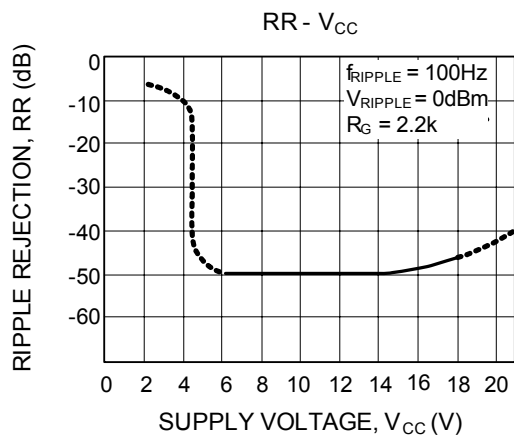
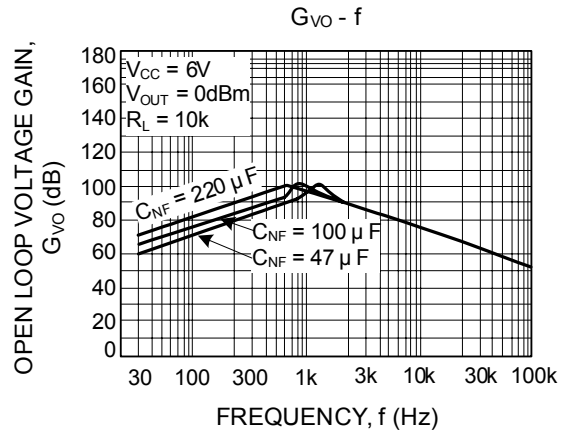
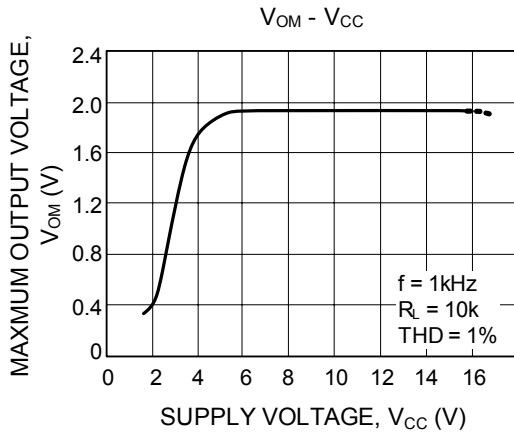
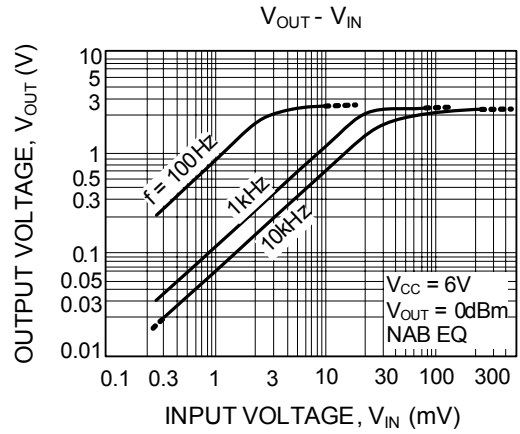
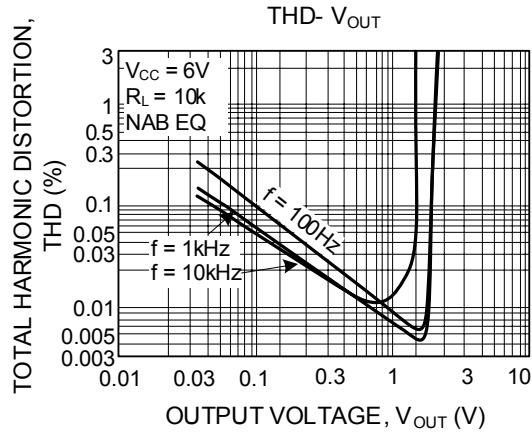

■ TYPICAL CHARACTERISTICS

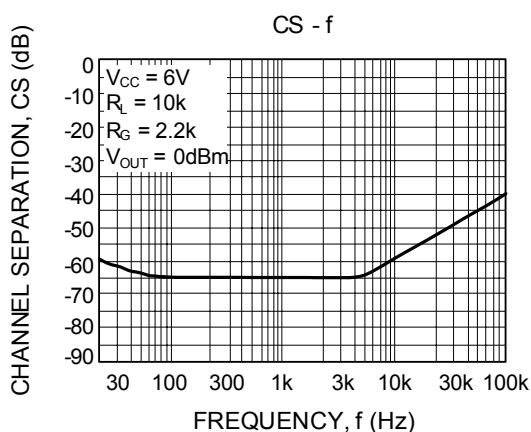
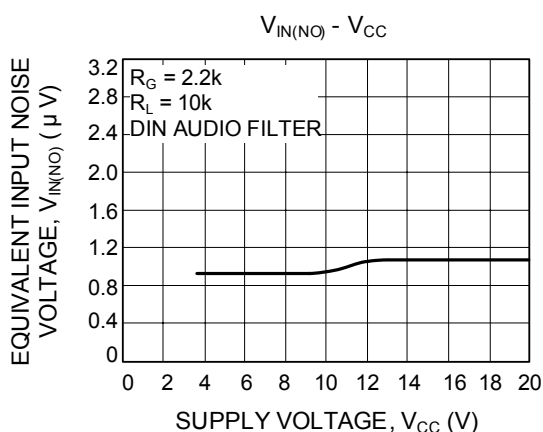
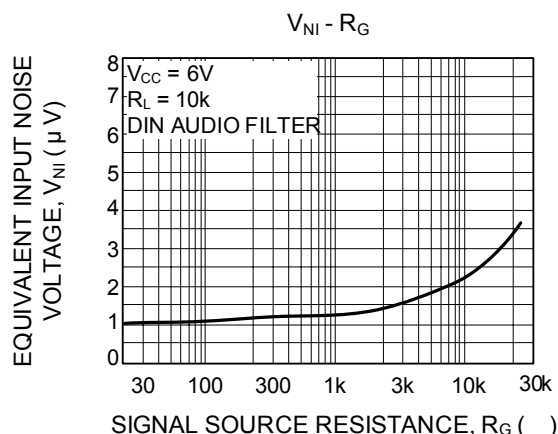
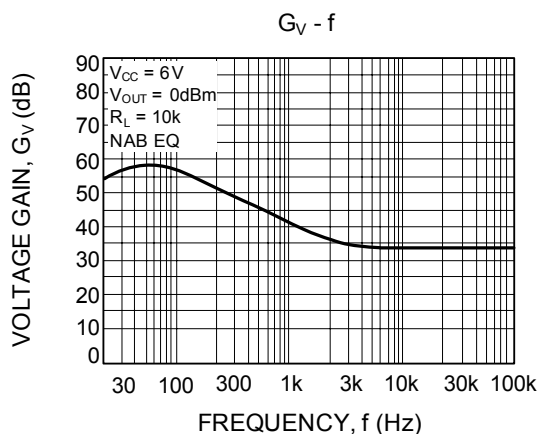
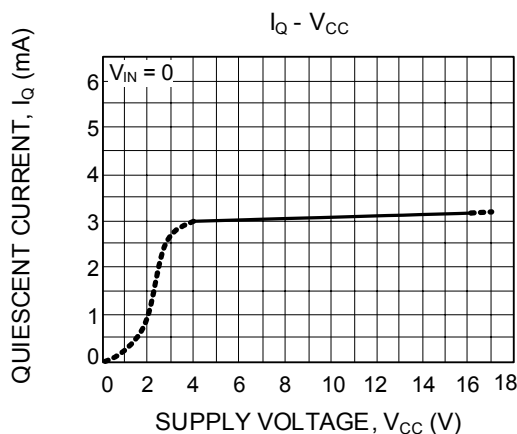
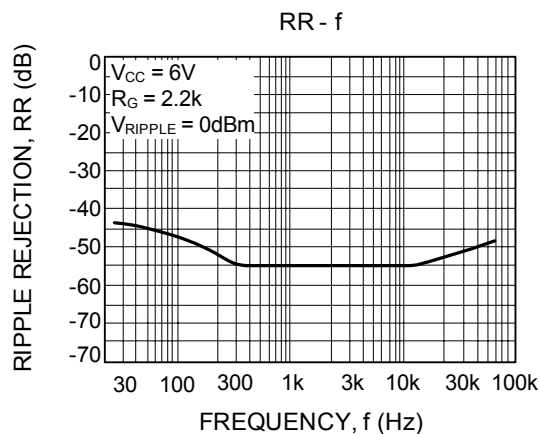

UTC assumes no responsibility for equipment failures that result from using products at values that exceed, even momentarily, rated values (such as maximum ratings, operating condition ranges, or other parameters) listed in products specifications of any and all UTC products described or contained herein. UTC products are not designed for use in life support appliances, devices or systems where malfunction of these products can be reasonably expected to result in personal injury. Reproduction in whole or in part is prohibited without the prior written consent of the copyright owner. The information presented in this document does not form part of any quotation or contract, is believed to be accurate and reliable and may be changed without notice.