

Round, solder lead type
Series: BCAP



› **Features:**

- › Dimensions similar to EN 60086-2 & EN 60285
- › Over 500,000 duty cycles
- › 10 year life capability
- › Higher energy vs. electrolytic
- › Higher power vs. batteries
- › Aluminum construction
- › Round, double ended design
- › Ultra-low internal resistance
- › Resistant against reverse polarity
- › UL Recognized

› **Applications:**

- › Automotive subsystems
- › Heavy duty vehicle subsystems
- › Rail system power
- › Windmill pitch control systems
- › Wireless transmissions



› **Dimensions:**

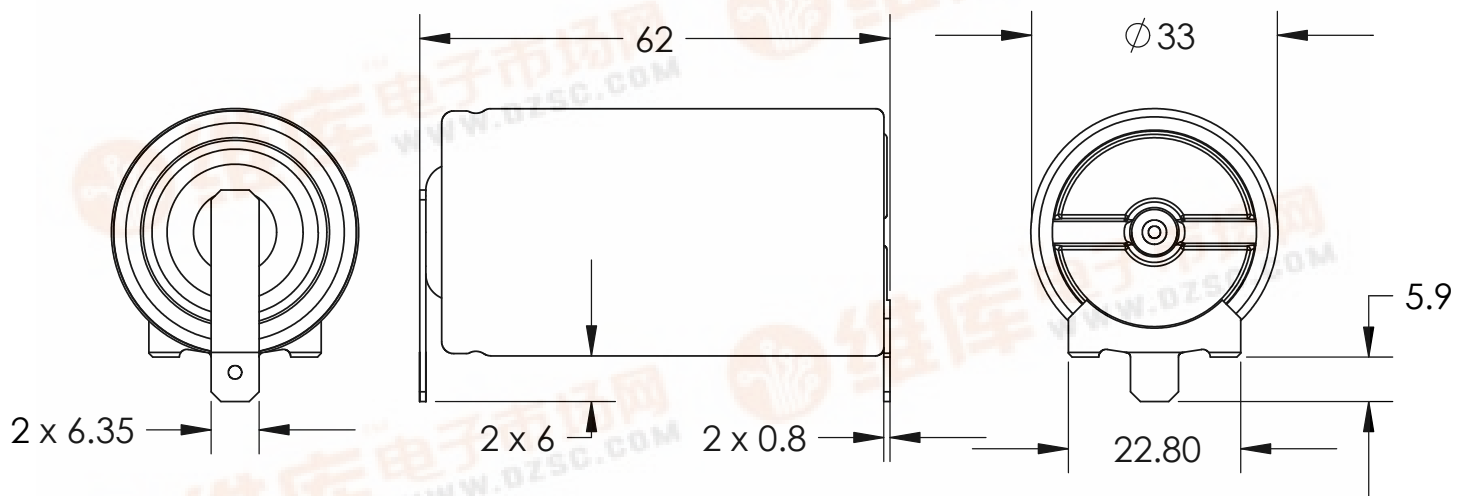

Dimensions, mm					
Case Size	L	OD	Weight [g]	Vol. [l]	Typical package qty.
BCAP0350	62	33	60	0.05	40

Product dimensions and specifications may change without notice. Please contact Maxwell Technologies directly for any technical specifications critical to application.



› Specifications:

	Product Specification		
	BCAP0350	Tolerance	Standard
Mounting	Solder		
Capacitance, C _R [F]	350	+/- 20%	
Voltage, U _R	2.5		
Internal resistance, DC [ohm]	0.0032	+/- 25 %	Discharging at Constant Current (25°C)
Internal resistance, 1 kHz [ohm]	0.0016	+/- 25 %	
Thermal Resistance, R _{th} (°C/W)	10.9		$\Delta T = DR_{th} I_c^2 R_d$
Short circuit current, I _{sc} [A]	1500		Caution , current possible with short circuit from U _R
Leakage current [mA]	1		72 hrs, 25°C
Operating temp. range [C]	-40 to 65		
Storage temp. range [C]	-40 to 70		
Endurance, Capacitance [F]	< 20% decrease		1000 hrs @ U _R and 65°C
Endurance, Resistance [ohm]	< 25% increase		
Maximum energy, E _{max} [Wh/kg]	5.1		Full discharge from U _R
Peak Power Density, P _d [W/kg]	16,275		Matched Load
Power Density, P _d [W/kg]	3,900		See additional technical information
Life Time	$\Delta C/C_R < 20\%$ decrease, ESR < 2 x increase		from initial value after 10y @ 25°C
Cycle Life	$\Delta C/C_R < 20\%$ decrease, ESR < 2 x increase		from initial value after 500K cycles @ 25°C (I = 5A)

› Markings: Capacitors are marked with the following information

Rated capacitance, Rated voltage, product number, name of manufacturer, UL symbol, positive terminal, negative terminal and warning marking

› Mounting Recommendations:

Cells are designed to be soldered into series or parallel strings.

Components should not be operated outside recommended limits.

Parts can be ordered without tabs.

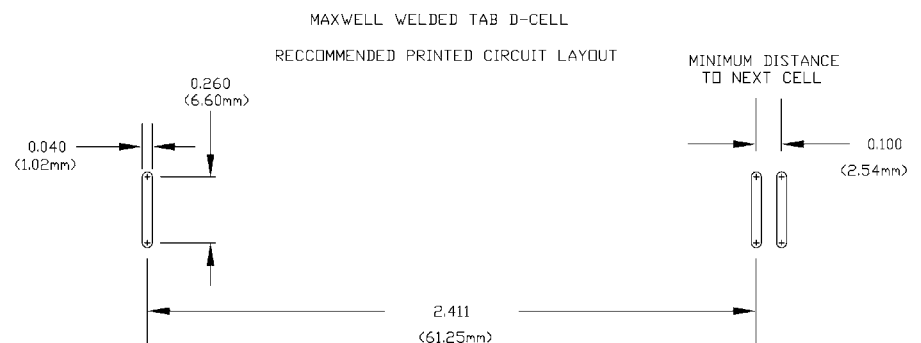

› Additional Technical Information:

$$P_d = (0.12 \times E^2 / R_d) / M$$

$$\Delta T = DR_{th} I_c^2 R_d$$

E = charge voltage (U_R)

M = capacitor weight (kg)

D = duty cycle

R_d = internal resistance (DC)

V = capacitor volume (l)

I_c = continuous current

› ΔT - duty cycle vs. operating current:

- › Curves generated under free convection at 25°C ambient

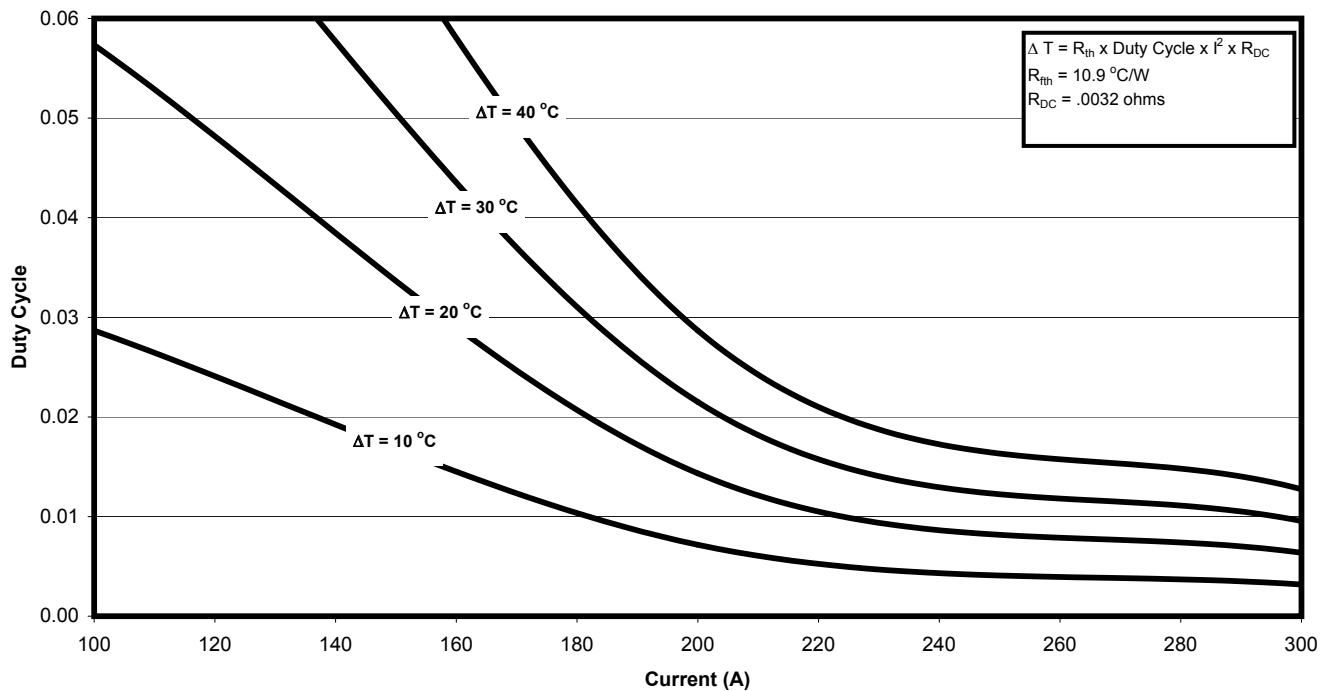
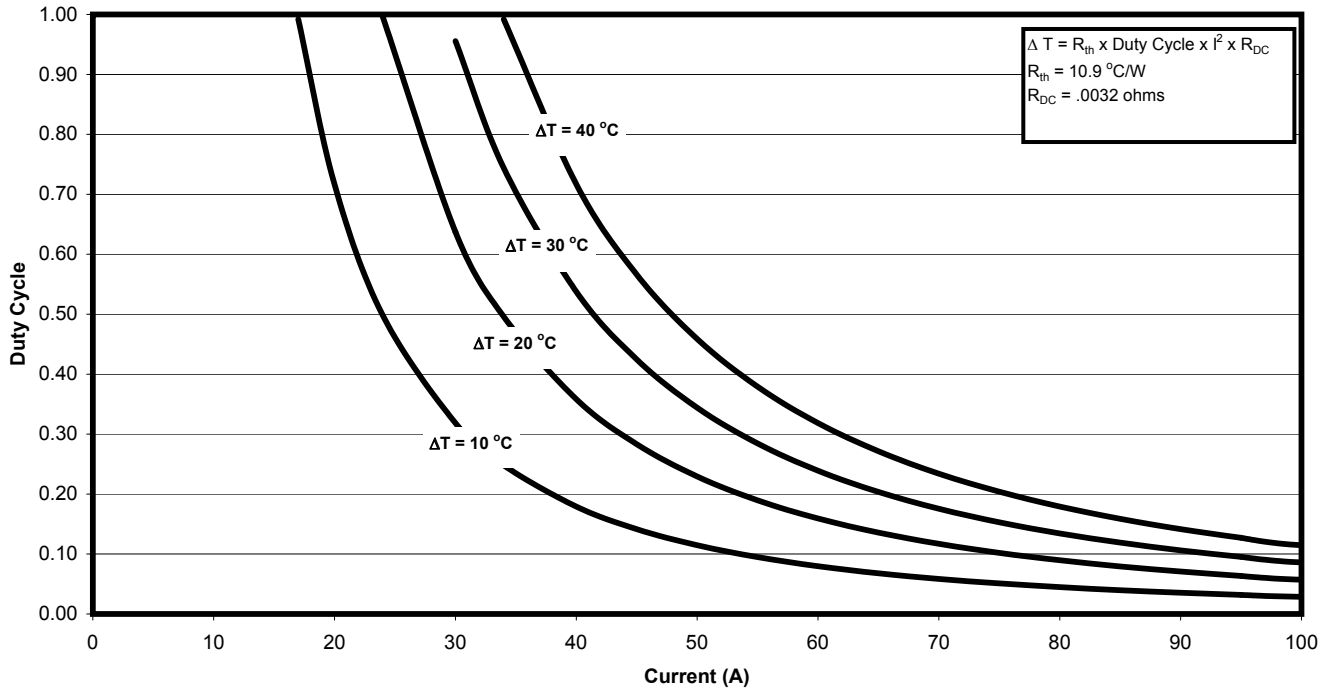

Patent Pending

Worldwide Headquarters

MAXWELL TECHNOLOGIES
 9244 Balboa Avenue • San Diego, 92123 CA, USA
 PHONE: +(1) 858 503 3300
 FAX: +(1) 858 503 3301
 EMAIL: info@maxwell.com

European Office

MAXWELL TECHNOLOGIES SA
 CH-1728 Rossens • Switzerland
 PHONE: +41 (0) 26 411 85 00
 FAX: +41 (0) 26 411 85 05
 EMAIL: info@maxwell.com