

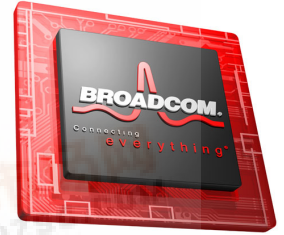

BCM5220 PRODUCT Brief



10/100BASE-TX SINGLE-CHANNEL SIGNI-PHY™ TRANSCEIVER

FEATURES

- Power supply: 2.5V or 3.3V
- Integrated voltage regulator to allow operation from a single supply source
- Power consumption: <275 mW
- Unique energy detection circuit to enable intelligent power management
- Cable length indication
- Cable noise level indication
- Robust CESD tolerance
- Cable length greater than 140 meters
- Well under 10 PPM defect ratio quality
- ±10% voltage tolerance
- Industrial temperature range (-40 to 85°C)
- MII and 7-wire serial interface configurable
- IEEE 1149.1 (JTAG) scan chain support
- MII management via serial port
- Pin-compatible with BCM5221
- 10BASE-T/100BASE-TX/FX IEEE 802.3u Fast Ethernet transceiver
- 64-pin TQFP or 64-pin BGA package

SUMMARY OF BENEFITS

- Provides low power and intelligent power management
 - Increased active working time
 - Prolonged battery life in active standby
 - Increased reliability
- Improves ease of use and installation, reduced support cost
 - Advanced cable diagnostic features to enable remote monitoring and debug of cabling infrastructure
 - Resistance to CESD to reduce product destruction and product returns
- DSP-based Signi-PHY™ architecture ensures performance over temperature, voltage and process variation
 - Proven in over 400,000,000 Fast Ethernet ports
- Enables greater product flexibility with BCM5221 pin-compatibility
- Promotes ease of manufacturing with JTAG support
- Includes fully integrated TX/FX PHY transceiver (MII-to-TX magnetics or FX optics)
 - Lower system cost
 - Simplified system and board design

Embedded 10/100 BASE-TX Application

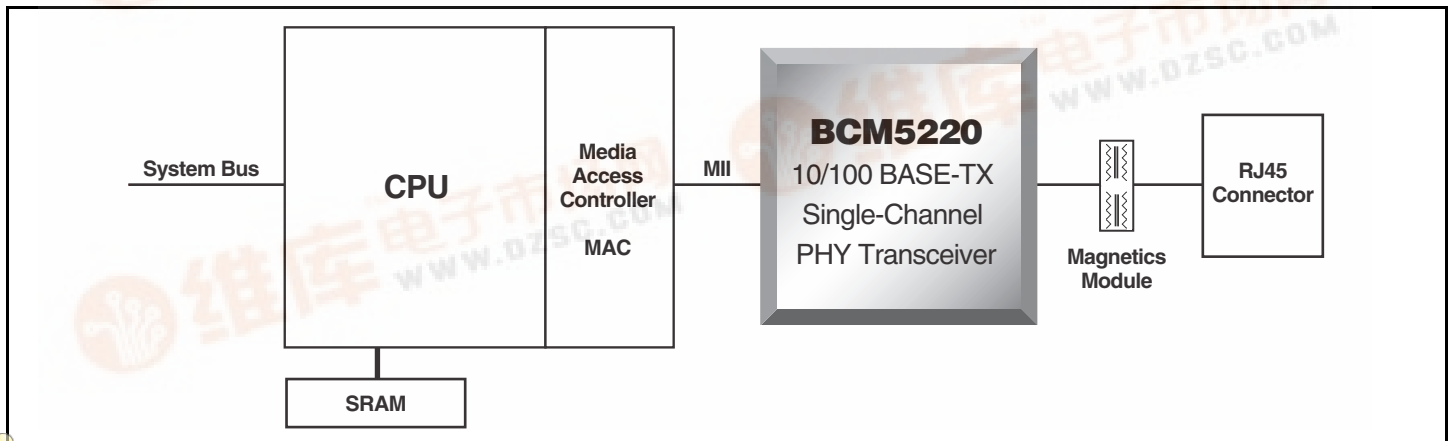

OVERVIEW

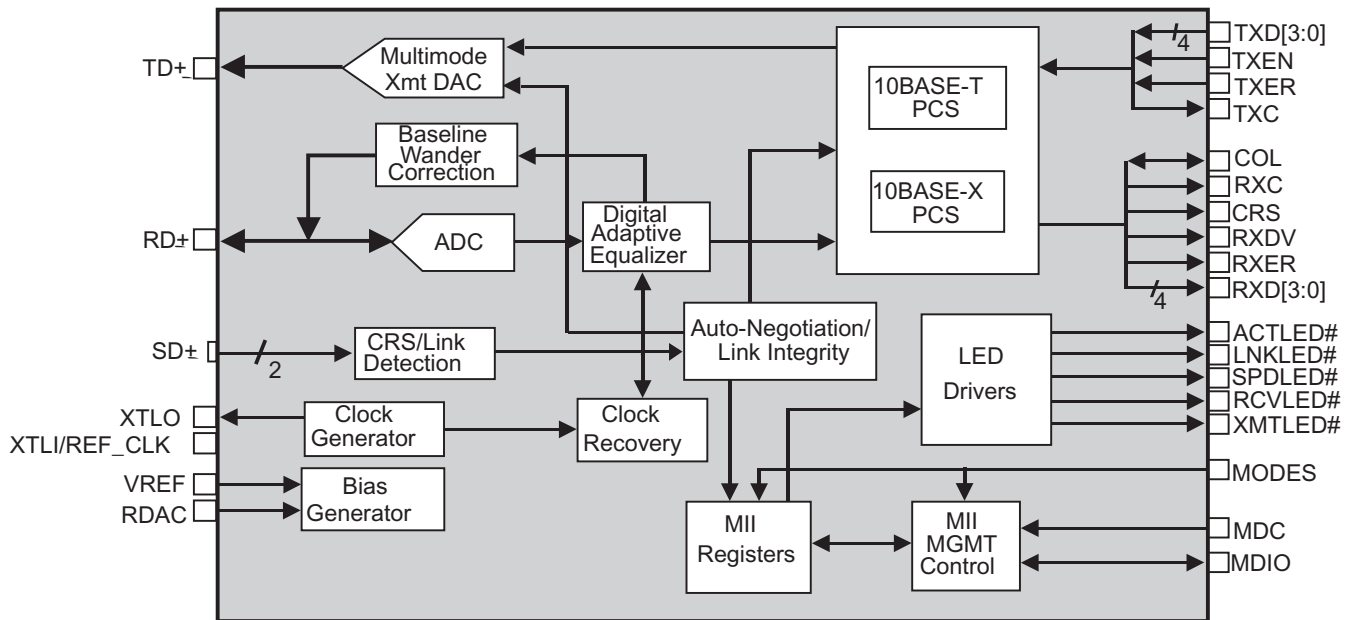

Lowest-Power Fast Ethernet PHY

With a power dissipation of 250 mW, the BCM5220 is the industry's lowest-power Fast Ethernet PHY. It features an integrated voltage regulator, and can be supplied by either a 2.5V or 3.3V power source. In addition, the BCM5220 has several intelligent power-down states that conserve power, yet allow products based on it to automatically turn on when needed.

The BCM5220 includes a unique Intelligent Power-Management feature that powers down the device if energy is not detected on the cable. This feature is especially useful for portable and power-sensitive applications such as laptop LAN card adapters. The BCM5220 allows PCMCIA or CardBus adapters to remain plugged in and draw virtually no energy even if the client is no longer connected to the network. Because most laptop users do not remove their LAN PC card when working remotely, this feature results in a noticeably extended battery life for laptop computer users.

The BCM5220 can be set to periodically wake up at a user-defined interval, allowing the product to initiate keep-alive traffic on the network. For lowest power consumption, the BCM5220 can be put in a power-off state (<2.5 mW).

Network Tolerance

Cable-sourced electrostatic discharge (CESD) is a recently discovered phenomenon that occurs when an electrically charged network cable is plugged into a networked product, an issue becoming more prevalent with recent cable installations. The BCM5220 has been designed and tested to withstand over 5 KV of CESD, which unlike other transceivers prevents the device from being destroyed in a CESD event.

DSP-Based PHY Technology

The BCM5220 builds on Broadcom's proven DSP PHY design and full custom circuit design techniques to create a highly integrated and robust physical layer solution. DSP techniques allow the BCM5220 to achieve high interoperability and to exhibit robust performance across voltage ($\pm 0\%$), temperature (-40 to 85°C), and process variations. Broadcom's DSP-based, Digi-PHY™ technology has been proven in the shipment of over 400,000,000 Fast Ethernet ports. Broadcom's superior quality has resulted in a failure rate well under 10 PPM.

Broadcom®, the pulse logo, Signi-PHY™, Digi-PHY™ and Connecting everything® are trademarks of Broadcom Corporation and/or its subsidiaries in the United States and certain other countries. All other trademarks mentioned are the property of their respective owners.

Connecting
everything®



BROADCOM CORPORATION
16215 Alton Parkway, P.O. Box 57013
Irvine, California 92619-7013

© 2004 by BROADCOM CORPORATION. All rights reserved.

Phone: 949-450-8700
Fax: 949-450-8710
E-mail: info@broadcom.com
Web: www.broadcom.com