



BC857AT, BT, CT

PNP SMALL SIGNAL SURFACE MOUNT TRANSISTOR

NEW PRODUCT

Features

- Epitaxial Die Construction
- Complementary NPN Types Available (BC847AT, BT, CT)
- Ultra-Small Surface Mount Package

Mechanical Data

- Case: SOT-523, Molded Plastic
- Case material - UL Flammability Rating Classification 94V-0
- Moisture sensitivity: Level 1 per J-STD-020A
- Terminals: Solderable per MIL-STD-202, Method 208
- Terminal Connections: See Diagram
- Weight: 0.002 grams (approx.)
- Marking Codes (See Table Below & Diagrams on Page 2)
- Ordering & Date Code Information: See Page 2

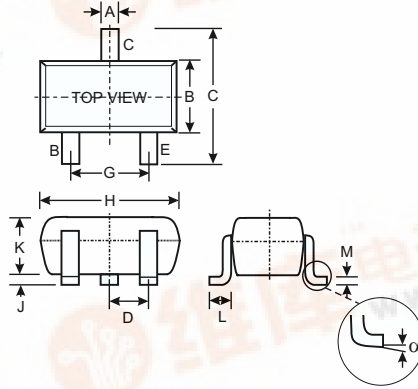

SOT-523			
Dim	Min	Max	Typ
A	0.15	0.30	0.22
B	0.75	0.85	0.80
C	1.45	1.75	1.60
D	—	—	0.50
G	0.90	1.10	1.00
H	1.50	1.70	1.60
J	0.00	0.10	0.05
K	0.60	0.80	0.75
L	0.10	0.30	0.22
M	0.10	0.20	0.12
N	0.45	0.65	0.50
α	0°	8°	—
All Dimensions in mm			

Type	Marking
BC857AT	3V
BC857BT	3W
BC857CT	3G

Maximum Ratings @ $T_A = 25^\circ\text{C}$ unless otherwise specified

Characteristic	Symbol	Value	Unit
Collector-Base Voltage	V_{CB0}	-50	V
Collector-Emitter Voltage	V_{CE0}	-45	V
Emitter-Base Voltage	V_{EB0}	-5.0	V
Collector Current	I_C	-100	mA
Power Dissipation (Note 1)	P_d	150	mW
Thermal Resistance, Junction to Ambient (Note 1)	$R_{\theta JA}$	833	$^\circ\text{C}/\text{W}$
Operating and Storage Temperature Range	T_J, T_{STG}	-55 to +150	$^\circ\text{C}$

Notes: 1. Device mounted on FR-4 PCB, 1 inch x 0.85 inch x 0.062 inch; pad layout as shown on Diodes Inc. suggested pad layout document AP02001, which can be found on our website at <http://www.diodes.com/datasheets/ap02001.pdf>.



Electrical Characteristics @ $T_A = 25^\circ\text{C}$ unless otherwise specified

Characteristic	Symbol	Min	Typ	Max	Unit	Test Condition
Collector-Base Breakdown Voltage (Note 2)	$V_{(BR)CBO}$	-50	—	—	V	$I_C = 10\mu\text{A}, I_B = 0$
Collector-Emitter Breakdown Voltage (Note 2)	$V_{(BR)CEO}$	-45	—	—	V	$I_C = 10\text{mA}, I_B = 0$
Emitter-Base Breakdown Voltage (Note 2)	$V_{(BR)EBO}$	-5	—	—	V	$I_E = 1\mu\text{A}, I_C = 0$
DC Current Gain (Note 2)	Current Gain A B C h_{FE}	125 220 420	— 290 520	250 475 800	—	$V_{CE} = -5.0\text{V}, I_C = -2.0\text{mA}$
Collector-Emitter Saturation Voltage (Note 2)	$V_{CE(SAT)}$	—	—	-300 -650	mV	$I_C = -10\text{mA}, I_B = -0.5\text{mA}$ $I_C = -100\text{mA}, I_B = -5.0\text{mA}$
Base-Emitter Saturation Voltage (Note 2)	$V_{BE(SAT)}$	—	-700 -900	—	mV	$I_C = -10\text{mA}, I_B = -0.5\text{mA}$ $I_C = -100\text{mA}, I_B = -5.0\text{mA}$
Base-Emitter Voltage (Note 2)	$V_{BE(ON)}$	-600 —	—	-750 -820	mV	$V_{CE} = -5.0\text{V}, I_C = -2.0\text{mA}$ $V_{CE} = -5.0\text{V}, I_C = -10\text{mA}$
Collector-Cutoff Current (Note 2)	I_{CBO}	—	—	-15 -4.0	NA μA	$V_{CB} = -30\text{V}$ $V_{CB} = -30\text{V}, T_A = 150^\circ\text{C}$
Gain Bandwidth Product	f_T	100	—	—	MHz	$V_{CE} = -5.0\text{V}, I_C = -10\text{mA}$, $f = 100\text{MHz}$
Output Capacitance	C_{OB}	—	—	4.5	pF	$V_{CB} = -10\text{V}, f = 1.0\text{MHz}$
Noise Figure	NF	—	—	10	dB	$I_C = -0.2\text{mA}, V_{CE} = -5.0\text{Vdc}$, $R_S = 2.0\text{K}\Omega, f = 1.0\text{KHz}$, $BW = 200\text{Hz}$

Ordering Information (Note 3)

Device	Packaging	Shipping
BC857AT-7	SOT-523	3000/Tape & Reel
BC857BT-7	SOT-523	3000/Tape & Reel
BC857CT-7	SOT-523	3000/Tape & Reel

- Notes: 2. Short duration pulse test used to minimize self-heating effect.
3. For Packaging Details: go to our website at <http://www.diodes.com/datasheets/ap02007.pdf>.

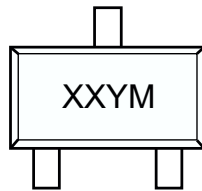
Marking Information

XX = Product Type Marking Code (See Page 1), e.g. 3V = BC857AT
YM = Date Code Marking
Y = Year (ex: N = 2002)
M = Month (ex: 9 = September)

Date Code Key

Year	1998	1999	2000	2001	2002	2003	2004
Code	J	K	L	M	N	P	R

Month	Jan	Feb	March	Apr	May	Jun	Jul	Aug	Sep	Oct	Nov	Dec
Code	1	2	3	4	5	6	7	8	9	O	N	D