



Structure Silicon Monolithic Integrated Circuit
 Product Name Power supply for CCD camera of mobile phone

Type **BD6020GU**

Features A system power supply for the CCD camera module
 Built-in constant current drive for the focus function

○Absolute Maximum Ratings (Ta=25 °C)

Parameter	Symbol	Rating	Unit	Condition
Maximum Applied Voltage 1	VMAX1	20(*1)	V	
Maximum Applied Voltage 2	VMAX2	17(*2)	V	
Maximum Applied Voltage 3	VMAX3	-15(*3)	V	
Maximum Applied Voltage 4	VMAX4	7(*4)	V	
Power Dissipation	Pd	1890(*5)	mW	
Operating Temperature Range	Topr	-30 to 75	°C	
Storage Temperature Range	Tstg	-55 to 150	°C	

(*1) SW, VPLUS11, VPLUS12 pin

(*2) CAMP pin

(*3) VNEG pin

(*4) Except Note1~Note3 pin

(*5) 50mm × 58mm × 1.75mm At grass epoxy board mounting.

When it's used by more than Ta=25 °C, it's reduced by the 15.1mW/°C

○Recommended operating conditions (Ta=-30 to 75 °C)

Parameter	Symbol	Rating			Unit	Condition
		Min.	Typ.	Max.		
VBAT power supply voltage	VBAT	2.7	3.6	4.5	V	
VIO power supply voltage	VIO	2.5	3.0	3.3	V	

This product isn't designed to protect itself against radioactive rays.

Status of this document

The Japanese version of this document is the formal specification.

A customer may use this translation version only for a reference to help reading the formal version.

If there are any differences in translation version of this document, formal version takes priority.

Application example

The product described in this specification is designed to be used with ordinary electronic equipment or devices (such as audio-visual equipment, office-automation equipment, communications devices, electrical appliances, and electronic toys).

Should you intend to use this product with equipment or devices which require an extremely high level of reliability and the malfunction of which would directly endanger human life (such as medical instruments, transportation equipment, aerospace machinery, nuclear-reactor controllers, fuel controllers and other safety devices), please be sure to consult with our sales representative in advance.



○Electrical Characteristics

Unless otherwise specified, Ta=25 °C, VBAT=3.6V, VIO=3.0V, REG1=REG2=Normal mode

Parameter	Symbol	Spec			Unit	Condition
		Min.	Typ.	Max.		
Circuit Current						
VBAT circuit current 1	IBAT1	-	0.1	3.0	μA	RSTB=0V→3.0V
VBAT circuit current 2	IBAT2	-	9	13.5	μA	REG1=REG2=ON, Io=0mA (Energy save mode)
VBAT circuit current 3	IBAT3	-	90	130	μA	REG1=ON, Io=0mA
VBAT circuit current 4	IBAT4	-	90	130	μA	REG2=ON, Io=0mA
VBAT circuit current 5	IBAT5	-	8	12	μA	Step-up DC/DC=REGCP=ON, Io=0mA
VBAT circuit current 6	IBAT6	-	11	16	μA	Inverted DC/DC=ON, Io=0mA
VIO circuit current	IVIO	-	80	120	μA	Constant current drive=ON, DR10-DR17=0
Step-up DC/DC						
Output voltage 1	VoPD1	-	16.3	-	V	Io=20mA, VSELP=0
Output voltage 2	VoPD2	-	14.3	-	V	Io=20mA, VSELP=1
Efficiency	EffPD	64	70	-	%	Io=20mA (*6)
Switching frequency	foscPD	0.64	0.80	0.96	MHz	
Over voltage protection	OvPD	18	19	20	V	
Inverted DC/DC						
Output voltage	VoND	-10.5	-10.0	-9.5	V	Io=100mA
Efficiency	EffND	60	67	-	%	Io=100mA (*6)
Switching frequency	foscND	0.64	0.80	0.96	MHz	
Over voltage protection	OvND	-13	-12	-11	V	
REGCP (15V/13V LDO)						
Output voltage 1	VoP1	14.5	15.0	15.5	V	Io=20mA, VSELP=0, VPLUS12=16V
Output voltage 2	VoP2	12.5	13.0	13.5	V	Io=20mA, VSELP=1 VPLUS12=14V
I/O voltage difference	VsatP	-	0.16	0.25	V	VPLUS12=12V, Io=20mA
Load stability	ΔVoP1	-	10	60	mV	Io=1~20mA
Current overload limiter	Ilim0P	100	230	300	mA	Vo=0V
REG1 (3V LDO)						
Output voltage	Vo1	2.94	3.0	3.06	V	Io=80mA
	Vo1S	2.94	3.0	3.06	V	Io=1mA, Energy save mode
I/O voltage difference	Vsat1	-	0.2	0.3	V	VBAT2=2.5V, Io=80mA
Load stability	ΔVo11	-	10	60	mV	Io=1~80mA
Current overload limiter	Ilim01	180	400	620	mA	Vo=0V
REG2 (1.8V/2.5V LDO)						
Output voltage 1	Vo21	1.74	1.80	1.86	V	Io=60mA, VSEL2=L
	Vo21S	1.74	1.80	1.86	V	Io=1mA, VSEL2=L, Energy save mode
Output voltage 2	Vo22	2.45	2.50	2.55	V	Io=60mA, VSEL2=H
	Vo22S	2.45	2.50	2.55	V	Io=1mA, VSEL2=H, Energy save mode
I/O voltage difference	Vsat	-	0.2	0.3	V	Io=60mA, VBAT=2.5V, VSEL2=H
Load stability	Δvo21	-	10	60	mV	Io=1~60mA
Current over limiter	Ilim02	120	280	440	mA	Vo=0V
Constant current drive						
CURSENS pin control voltage 1	I _{CUR1}	-	0	0.03	V	Address=EH, Data=00H
CURSENS pin control voltage 2	I _{CUR2}	0.27	0.30	0.33	V	Address=EH, Data=7FH
CURSENS pin control voltage 3	I _{CUR3}	0.57	0.60	0.63	V	Address=EH, Data=FFH

(*6) Efficiency is subject to the characters of external components and conditions of board mounting.

External dimensions

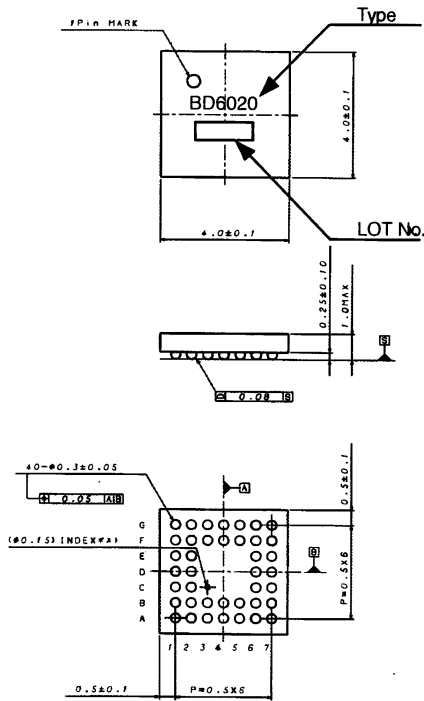

VCSP85H4 (40PIN) (Unit : mm)

Terminals

PIN	PIN Name	PIN	PIN Name
A1	GNDT1	D6	TEST2
A2	VBAT1	D7	VOUT2
A3	GND1	E1	CNTOUT
A4	VIO	E2	VSEL2
A5	CLK	E6	VREF
A6	RSTB	E7	CURSENS
A7	T2	F1	GNDP
B1	VNEG	F2	GND3
B2	NC	F3	VBAT3
B3	TRSW	F4	REG2CNT
B4	DATA	F5	VPLUS11
B5	STRB	F6	GND2
B6	TEST1	F7	CUR
B7	VOUT1	G1	T4
C1	SENSN1	G2	SW
C2	SENSN2	G3	VBATP
C6	VBAT2B	G4	REG1CNT
C7	VBAT2A	G5	VPLUS12
D1	SENSP2	G6	CAMP
D2	SENSP1	G7	GNDT3

Block diagram

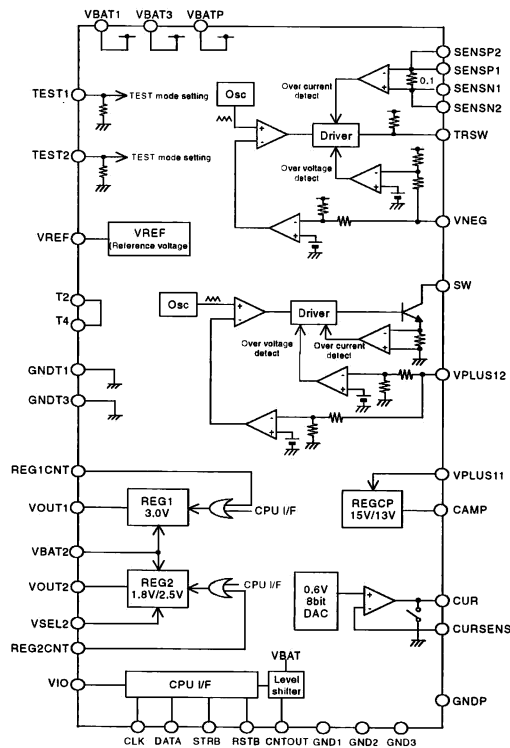

○Cautions on use

(1) Absolute Maximum Ratings

An excess in the absolute maximum ratings, such as supply voltage, temperature range of operating conditions, etc., can break down devices, thus making impossible to identify breaking mode such as a short circuit or an open circuit. If any special mode exceeding the absolute maximum ratings is assumed, consideration should be given to take physical safety measures including the use of fuses, etc.

(2) Power supply and GND line

Design PCB pattern to provide low impedance for the wiring between the power supply and the GND lines. Pay attention to the interference by common impedance of layout pattern when there are plural power supplies and GND lines. Especially, when there are GND pattern for small signal and GND pattern for large current included the external circuits, please separate each GND pattern. Furthermore, for all power supply terminals to ICs, mount a capacitor between the power supply and the GND terminal. At the same time, in order to use a capacitor, thoroughly check to be sure the characteristics of the capacitor to be used present no problem including the occurrence of capacity dropout at a low temperature, thus determining the constant.

(3) GND voltage

Make setting of the potential of the GND terminal so that it will be maintained at the minimum in any operating state. Furthermore, check to be sure no terminals are at a potential lower than the GND voltage including an actual electric transient.

(4) Short circuit between terminals and erroneous mounting

In order to mount ICs on a set PCB, pay thorough attention to the direction and offset of the ICs. Erroneous mounting can break down the ICs. Furthermore, if a short circuit occurs due to foreign matters entering between terminals or between the terminal and the power supply or the GND terminal, the ICs can break down.

(5) Operation in strong electromagnetic field

Be noted that using ICs in the strong electromagnetic field can malfunction them.

(6) Input terminals

In terms of the construction of IC, parasitic elements are inevitably formed in relation to potential. The operation of the parasitic element can cause interference with circuit operation, thus resulting in a malfunction and then breakdown of the input terminal. Therefore, pay thorough attention not to handle the input terminals, such as to apply to the input terminals a voltage lower than the GND respectively, so that any parasitic element will operate. Furthermore, do not apply a voltage to the input terminals when no power supply voltage is applied to the IC. In addition, even if the power supply voltage is applied, apply to the input terminals a voltage lower than the power supply voltage or within the guaranteed value of electrical characteristics.

(7) External capacitor

In order to use a ceramic capacitor as the external capacitor, determine the constant with consideration given to a degradation in the nominal capacitance due to DC bias and changes in the capacitance due to temperature, etc.

(8) Thermal shutdown circuit (TSD)

This LSI builds in a thermal shutdown (TSD) circuit. When junction temperatures become detection temperature or higher, the thermal shutdown circuit operates and turns a switch OFF. The thermal shutdown circuit, which is aimed at isolating the LSI from thermal runaway as much as possible, is not aimed at the protection or guarantee of the LSI. Therefore, do not continuously use the LSI with this circuit operating or use the LSI assuming its operation.

(9) Thermal design

Perform thermal design in which there are adequate margins by taking into account the permissible dissipation (Pd) in actual states of use.

(10) LDO

Use each output of LDO by the independence. Don't use under the condition that each output is short-circuited because it has the possibility that a operation becomes unstable.

(11) DC/DC converter

Please select the low DCR inductors to decrease power loss for DC/DC converter.

(12) Other cautions on use

Please consult supplementary documents such as technical notebook, function manual and application design guide of this LSI.

Notes

- No technical content pages of this document may be reproduced in any form or transmitted by any means without prior permission of ROHM CO.,LTD.
- The contents described herein are subject to change without notice. The specifications for the product described in this document are for reference only. Upon actual use, therefore, please request that specifications to be separately delivered.
- Application circuit diagrams and circuit constants contained herein are shown as examples of standard use and operation. Please pay careful attention to the peripheral conditions when designing circuits and deciding upon circuit constants in the set.
- Any data, including, but not limited to application circuit diagrams information, described herein are intended only as illustrations of such devices and not as the specifications for such devices. ROHM CO.,LTD. disclaims any warranty that any use of such devices shall be free from infringement of any third party's intellectual property rights or other proprietary rights, and further, assumes no liability of whatsoever nature in the event of any such infringement, or arising from or connected with or related to the use of such devices.
- Upon the sale of any such devices, other than for buyer's right to use such devices itself, resell or otherwise dispose of the same, no express or implied right or license to practice or commercially exploit any intellectual property rights or other proprietary rights owned or controlled by
- ROHM CO., LTD. is granted to any such buyer.
- Products listed in this document are no antiradiation design.

The products listed in this document are designed to be used with ordinary electronic equipment or devices (such as audio visual equipment, office-automation equipment, communications devices, electrical appliances and electronic toys).

Should you intend to use these products with equipment or devices which require an extremely high level of reliability and the malfunction of which would directly endanger human life (such as medical instruments, transportation equipment, aerospace machinery, nuclear-reactor controllers, fuel controllers and other safety devices), please be sure to consult with our sales representative in advance.

About Export Control Order in Japan

Products described herein are the objects of controlled goods in Annex 1 (Item 16) of Export Trade Control Order in Japan.

In case of export from Japan, please confirm if it applies to "objective" criteria or an "informed" (by MITI clause) on the basis of "catch all controls for Non-Proliferation of Weapons of Mass Destruction.

Thank you for your accessing to ROHM product informations.
More detail product informations and catalogs are available,
please contact your nearest sales office.

Please contact our sales offices for details ;

U.S.A / San Diego	TEL : +1(858)625-3630	FAX : +1(858)625-3670
Atlanta	TEL : +1(770)754-5972	FAX : +1(770)754-0691
Dallas	TEL : +1(972)312-8818	FAX : +1(972)312-0330
Germany / Dusseldorf	TEL : +49(2154)9210	FAX : +49(2154)921400
United Kingdom / London	TEL : +44(1)908-282-666	FAX : +44(1)908-282-528
France / Paris	TEL : +33(0)1 56 97 30 60	FAX : +33(0) 1 56 97 30 80
China / Hong Kong	TEL : +852(2)740-6262	FAX : +852(2)375-8971
Shanghai	TEL : +86(21)6279-2727	FAX : +86(21)6247-2066
Dilian	TEL : +86(411)8230-8549	FAX : +86(411)8230-8537
Beijing	TEL : +86(10)8525-2483	FAX : +86(10)8525-2489
Taiwan / Taipei	TEL : +866(2)2500-6956	FAX : +866(2)2503-2869
Korea / Seoul	TEL : +82(2)8182-700	FAX : +82(2)8182-715
Singapore	TEL : +65-6332-2322	FAX : +65-6332-5662
Malaysia / Kuala Lumpur	TEL : +60(3)7958-8355	FAX : +60(3)7958-8377
Philippines / Manila	TEL : +63(2)807-6872	FAX : +63(2)809-1422
Thailand / Bangkok	TEL : +66(2)254-4890	FAX : +66(2)256-6334

Japan /
(Internal Sales)

Tokyo	2-1-1, Yaesu, Chuo-ku, Tokyo 104-0082	TEL : +81(3)5203-0321	FAX : +81(3)5203-0300
Yokohama	2-4-8, Shin Yokohama, Kohoku-ku, Yokohama, Kanagawa 222-8575	TEL : +81(45)476-2131	FAX : +81(45)476-2128
Nagoya	Dainagayo Building 9F 3-28-12, Meieki, Nakamura-ku, Nagoya, Aichi 450-0002	TEL : +81(52)581-8521	FAX : +81(52)561-2173
Kyoto	579-32 Higashi Shiokouji-cho, Karasuma Nishi-iru, Shiokoujidori, Shimogyo-ku, Kyoto 600-8216	TEL : +81(75)311-2121	FAX : +81(75)314-6559

(Contact address for overseas customers in Japan)

Yokohama	TEL : +81(45)476-9270	FAX : +81(045)476-9271
----------	-----------------------	------------------------