

# BFG310/XR

## NPN 14 GHz wideband transistor

Rev. 01 — 2 February 2005

Product data sheet

## 1. Product profile

### 1.1 General description

NPN silicon planar epitaxial transistor in a 4-pin dual-emitter SOT143R plastic package.

### 1.2 Features

- High power gain
- Low noise figure
- High transition frequency
- Gold metallization ensures excellent reliability

### 1.3 Applications

- Intended for Radio Frequency (RF) front end applications in the GHz range, such as:
  - ◆ analog and digital cellular telephones
  - ◆ cordless telephones (Cordless Telephone (CT), Personal Communication Network (PCN), Digital Enhanced Cordless Telecommunications (DECT), etc.)
  - ◆ radar detectors
  - ◆ pagers
  - ◆ Satellite Antenna TeleVision (SATV) tuners
  - ◆ repeater amplifiers in fiber-optic systems

### 1.4 Quick reference data

Table 1: Quick reference data

Symbol	Parameter	Conditions	Min	Typ	Max	Unit
$V_{CBO}$	collector-base voltage	open emitter	-	-	15	V
$V_{CEO}$	collector-emitter voltage	open base	-	-	6	V
$I_C$	collector current (DC)		-	-	10	mA
$P_{tot}$	total power dissipation	$T_{sp} \leq 145 \text{ }^\circ\text{C}$	[1]	-	60	mW
$h_{FE}$	DC current gain	$I_C = 5 \text{ mA}; V_{CE} = 3 \text{ V}; T_j = 25 \text{ }^\circ\text{C}$	60	100	200	
$C_{CBS}$	collector-base capacitance	$V_{CB} = 5 \text{ V}; f = 1 \text{ MHz};$ emitter grounded	-	0.17	0.3	pF
$f_T$	transition frequency	$I_C = 5 \text{ mA}; V_{CE} = 3 \text{ V};$ $f = 1 \text{ GHz}; T_{amb} = 25 \text{ }^\circ\text{C}$	-	14	-	GHz

**Table 1: Quick reference data ...continued**

Symbol	Parameter	Conditions	Min	Typ	Max	Unit
MSG	maximum stable gain	$I_C = 5 \text{ mA}; V_{CE} = 3 \text{ V};$ $f = 1.8 \text{ GHz}; T_{amb} = 25 \text{ }^\circ\text{C}$	-	18	-	dB
$ S_{21} ^2$	insertion power gain	$I_C = 5 \text{ mA}; V_{CE} = 3 \text{ V};$ $f = 1.8 \text{ GHz}; T_{amb} = 25 \text{ }^\circ\text{C};$ $Z_S = Z_L = 50 \text{ } \Omega$	-	14	-	dB
NF	noise figure	$\Gamma_S = \Gamma_{opt}; I_C = 1 \text{ mA};$ $V_{CE} = 3 \text{ V}; f = 2 \text{ GHz}$	-	1	-	dB

[1]  $T_{sp}$  is the temperature at the soldering point of the collector pin.

## 2. Pinning information

**Table 2: Pinning**

Pin	Description	Simplified outline	Symbol
1	collector		
2	emitter		
3	base		
4	emitter		

*sym086*

## 3. Ordering information

**Table 3: Ordering information**

Type number	Package		
	Name	Description	Version
BFG310/XR	SC-61AA	plastic surface mounted package; reverse pinning; 4 leads	SOT143R

## 4. Marking

**Table 4: Marking codes**

Type number	Marking code <a href="#">[1]</a>
BFG310/XR	S1*

[1] \* = p: made in Hong Kong.

## 5. Limiting values

**Table 5: Limiting values**

In accordance with the Absolute Maximum Rating System (IEC 60134).

Symbol	Parameter	Conditions	Min	Max	Unit
$V_{CBO}$	collector-base voltage	open emitter	-	15	V
$V_{CEO}$	collector-emitter voltage	open base	-	6	V
$V_{EBO}$	emitter-base voltage	open collector	-	2	V
$I_C$	collector current (DC)		-	10	mA
$P_{tot}$	total power dissipation	$T_{sp} \leq 145\text{ °C}$	[1] -	60	mW
$T_{stg}$	storage temperature		-65	+175	°C
$T_j$	junction temperature		-	175	°C

[1]  $T_{sp}$  is the temperature at the soldering point of the collector pin.

## 6. Thermal characteristics

**Table 6: Thermal characteristics**

Symbol	Parameter	Conditions	Typ	Unit
$R_{th(j-sp)}$	thermal resistance from junction to solder point	$T_{sp} \leq 145\text{ °C}$	[1] 530	K/W

[1]  $T_{sp}$  is the temperature at the soldering point of the collector pin.

## 7. Characteristics

**Table 7: Characteristics**

$T_j = 25\text{ °C}$ ; unless otherwise specified.

Symbol	Parameter	Conditions	Min	Typ	Max	Unit
$I_{CBO}$	collector-base cut-off current	$I_E = 0\text{ A}$ ; $V_{CB} = 5\text{ V}$	-	-	15	nA
$h_{FE}$	DC current gain	$I_C = 5\text{ mA}$ ; $V_{CE} = 3\text{ V}$	60	100	200	
$C_{CBS}$	collector-base capacitance	$V_{CB} = 5\text{ V}$ ; $f = 1\text{ MHz}$ ; emitter grounded	-	0.17	0.3	pF
$C_{CES}$	collector-emitter capacitance	$V_{CE} = 5\text{ V}$ ; $f = 1\text{ MHz}$ ; base grounded	-	0.28	-	pF
$C_{EBS}$	emitter-base capacitance	$V_{EB} = 0.5\text{ V}$ ; $f = 1\text{ MHz}$ ; collector grounded	-	0.22	-	pF
$f_T$	transition frequency	$I_C = 5\text{ mA}$ ; $V_{CE} = 3\text{ V}$ ; $f = 1\text{ GHz}$ ; $T_{amb} = 25\text{ °C}$	-	14	-	GHz
MSG	maximum stable gain	$I_C = 5\text{ mA}$ ; $V_{CE} = 3\text{ V}$ ; $f = 1.8\text{ GHz}$ ; $T_{amb} = 25\text{ °C}$	-	18	-	dB
$ s_{21} ^2$	insertion power gain	$I_C = 5\text{ mA}$ ; $V_{CE} = 3\text{ V}$ ; $T_{amb} = 25\text{ °C}$ ; $Z_S = Z_L = 50\ \Omega$				
		$f = 1.8\text{ GHz}$	-	14	-	dB
		$f = 3\text{ GHz}$	-	11	-	dB
NF	noise figure	$\Gamma_s = \Gamma_{opt}$ ; $I_C = 1\text{ mA}$ ; $V_{CE} = 3\text{ V}$ ; $f = 2\text{ GHz}$	-	1	-	dB
$P_{L(1dB)}$	output power at 1 dB gain compression	$I_C = 5\text{ mA}$ ; $V_{CE} = 3\text{ V}$ ; $f = 1.8\text{ GHz}$ ; $T_{amb} = 25\text{ °C}$ ; $Z_S = Z_L = 50\ \Omega$	-	1.8	-	dBm
IP3	third order intercept point	$I_C = 5\text{ mA}$ ; $V_{CE} = 3\text{ V}$ ; $f = 1.8\text{ GHz}$ ; $T_{amb} = 25\text{ °C}$ ; $Z_S = Z_L = 50\ \Omega$	-	8.5	-	dBm

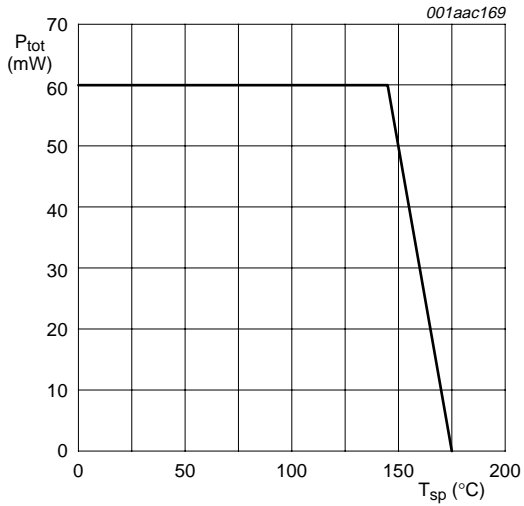

Fig 1. Power derating curve

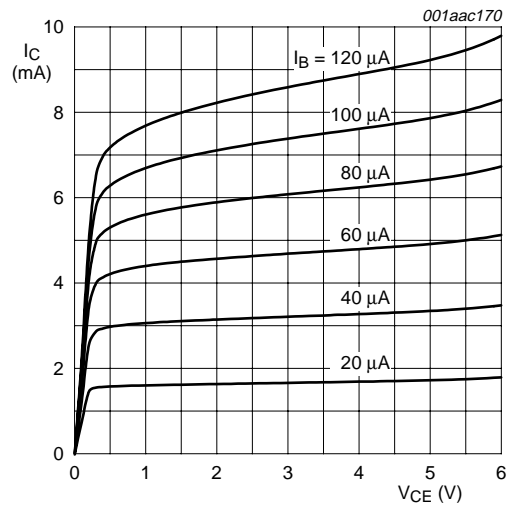
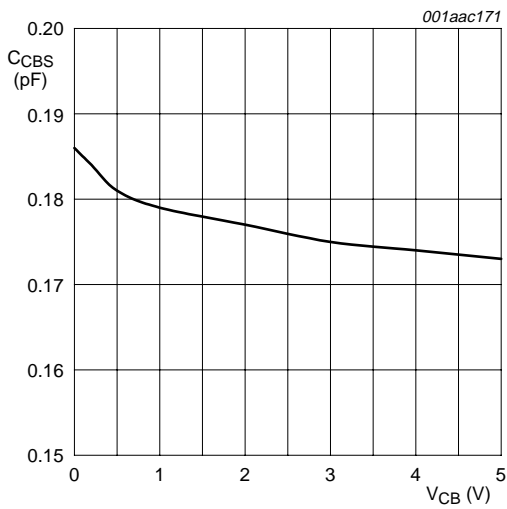
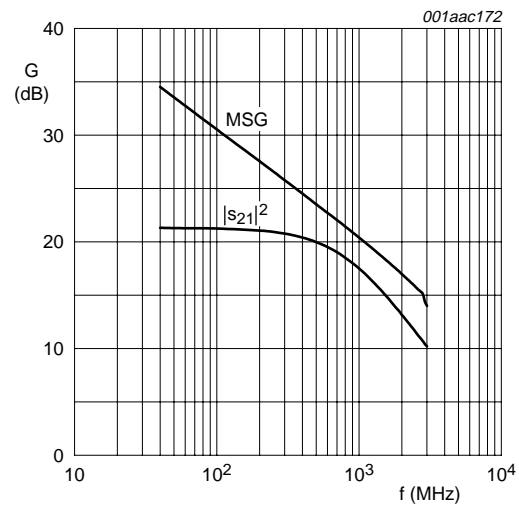

Fig 2. Collector current as a function of collector-emitter voltage; typical values



$I_C = 0 \text{ mA}; f = 1 \text{ MHz}.$

Fig 3. Collector-base capacitance as a function of collector-base voltage; typical values



$I_C = 5 \text{ mA}; V_{CE} = 3 \text{ V}.$

Fig 4. Gain as a function of frequency; typical values

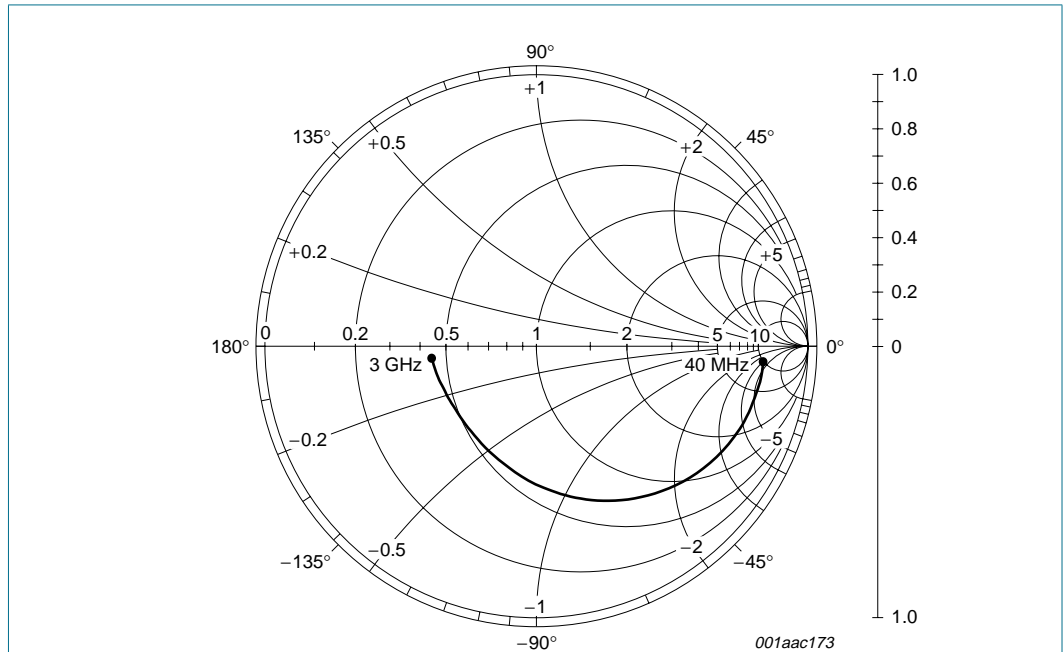

$V_{CE} = 3\text{ V}; I_C = 5\text{ mA}; Z_o = 50\ \Omega.$

**Fig 5. Common emitter input reflection coefficient ( $s_{11}$ ); typical values**

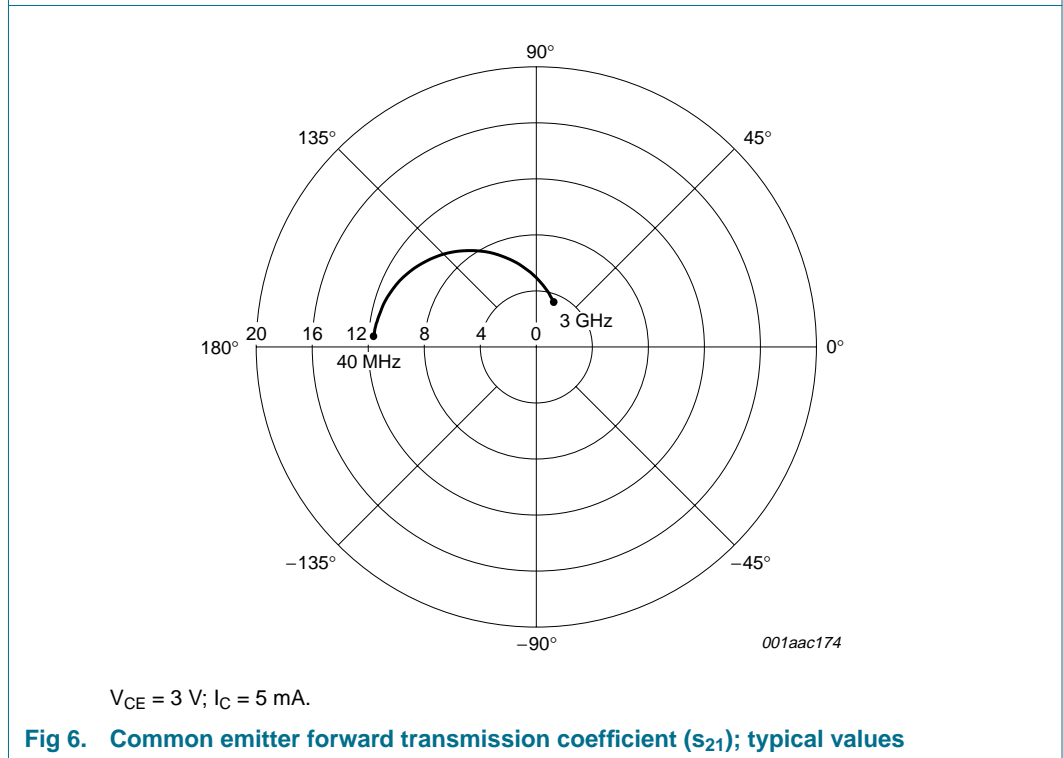

$V_{CE} = 3\text{ V}; I_C = 5\text{ mA}.$

**Fig 6. Common emitter forward transmission coefficient ( $s_{21}$ ); typical values**

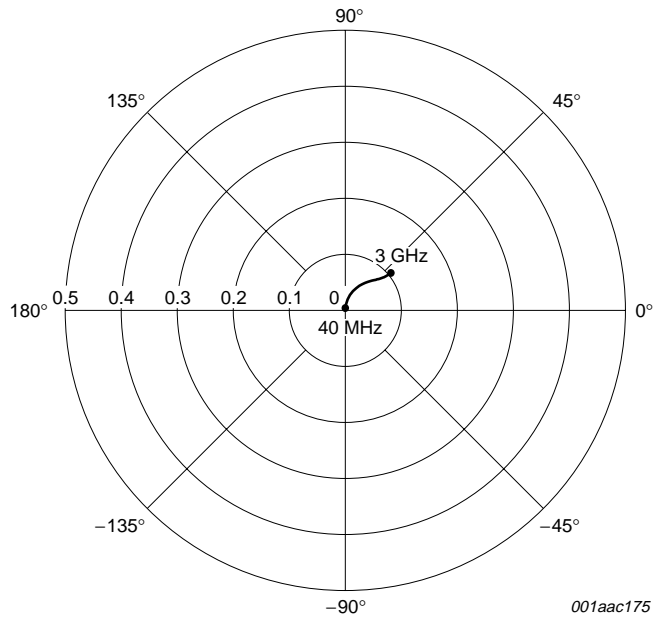

$V_{CE} = 3\text{ V}; I_C = 5\text{ mA}$ .

**Fig 7. Common emitter reverse transmission coefficient ( $s_{12}$ ); typical values**

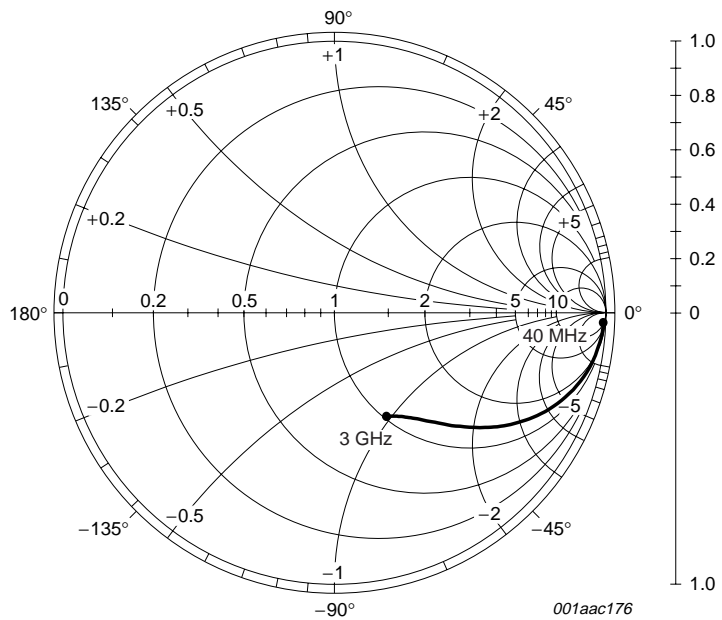

$V_{CE} = 3\text{ V}; I_C = 5\text{ mA}; Z_0 = 50\ \Omega$ .

**Fig 8. Common emitter output reflection coefficient ( $s_{22}$ ); typical values**

## 8. Application information

Table 8: SPICE parameters of the BFG310 DIE

Sequence	Parameter	Value	Unit
1	IS	16.17	aA
2	BF	210	-
3	NF	1	-
4	VAF	50	V
5	IKF	59.83	mA
6	ISE	1.726	fA
7	NE	2.114	-
8	BR	6	-
9	NR	1	-
10	VAR	2.3	V
11	IKR	10	A
12	ISC	0	aA
13	NC	1.5	-
14	RB	3.6	$\Omega$
15	RE	2.1	$\Omega$
16	RC	1.6	$\Omega$
17	CJE	115.6	fF
18	VJE	866.3	mV
19	MJE	0.285	-
20	CJC	68.18	fF
21	VJC	601	mV
22	MJC	0.123	-
23	XCJC	1	-
24	FC	0.7	-
25	TF	8.3	ps
26	XTF	10	-
27	VTF	1000	V
28	ITF	150	mA
29	PTF	0	deg
30	TR	0	ns
31	KF	0	-
32	AF	1	-
33	TNOM	25	$^{\circ}\text{C}$
34	EG	1.014	eV
35	XTB	0	-
36	XTI	8	-
37	Q1.AREA	1	-

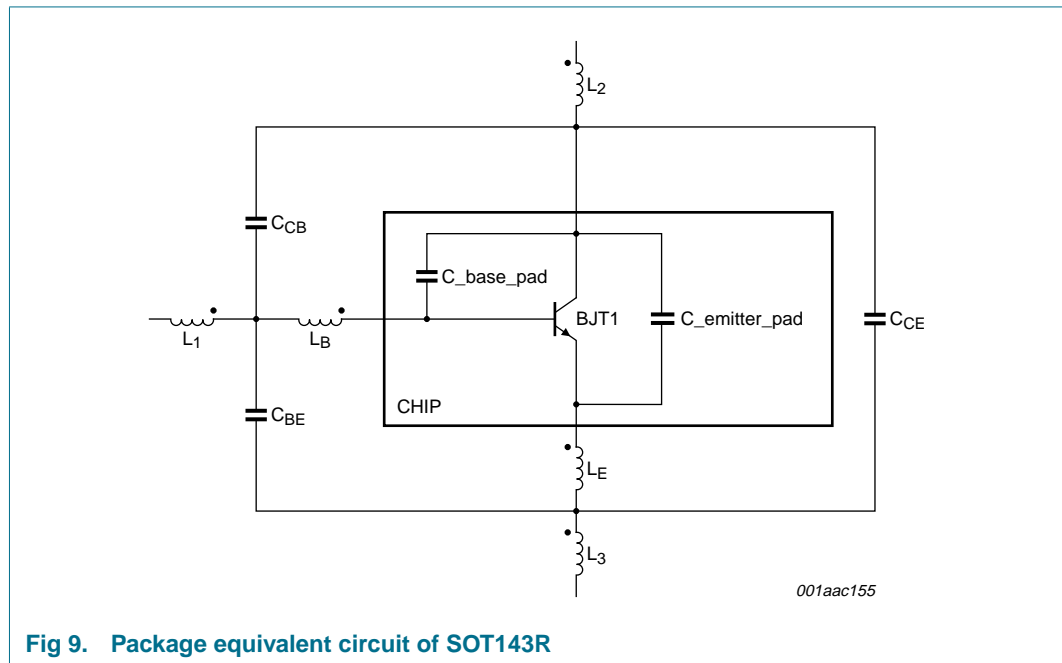

**Fig 9. Package equivalent circuit of SOT143R**

**Table 9: List of components; see [Figure 9](#)**

Designation	Value	Unit
$C_{CB}$	17	fF
$C_{BE}$	84	fF
$C_{CE}$	191	fF
$C_{base\_pad}$	67	fF
$C_{emitter\_pad}$	142	fF
$L_B$	0.95	nH
$L_E$	0.40	nH
$L_1$	0.12	nH
$L_2$	0.21	nH
$L_3$	0.06	nH

9. Package outline

Plastic surface mounted package; reverse pinning; 4 leads

SOT143R

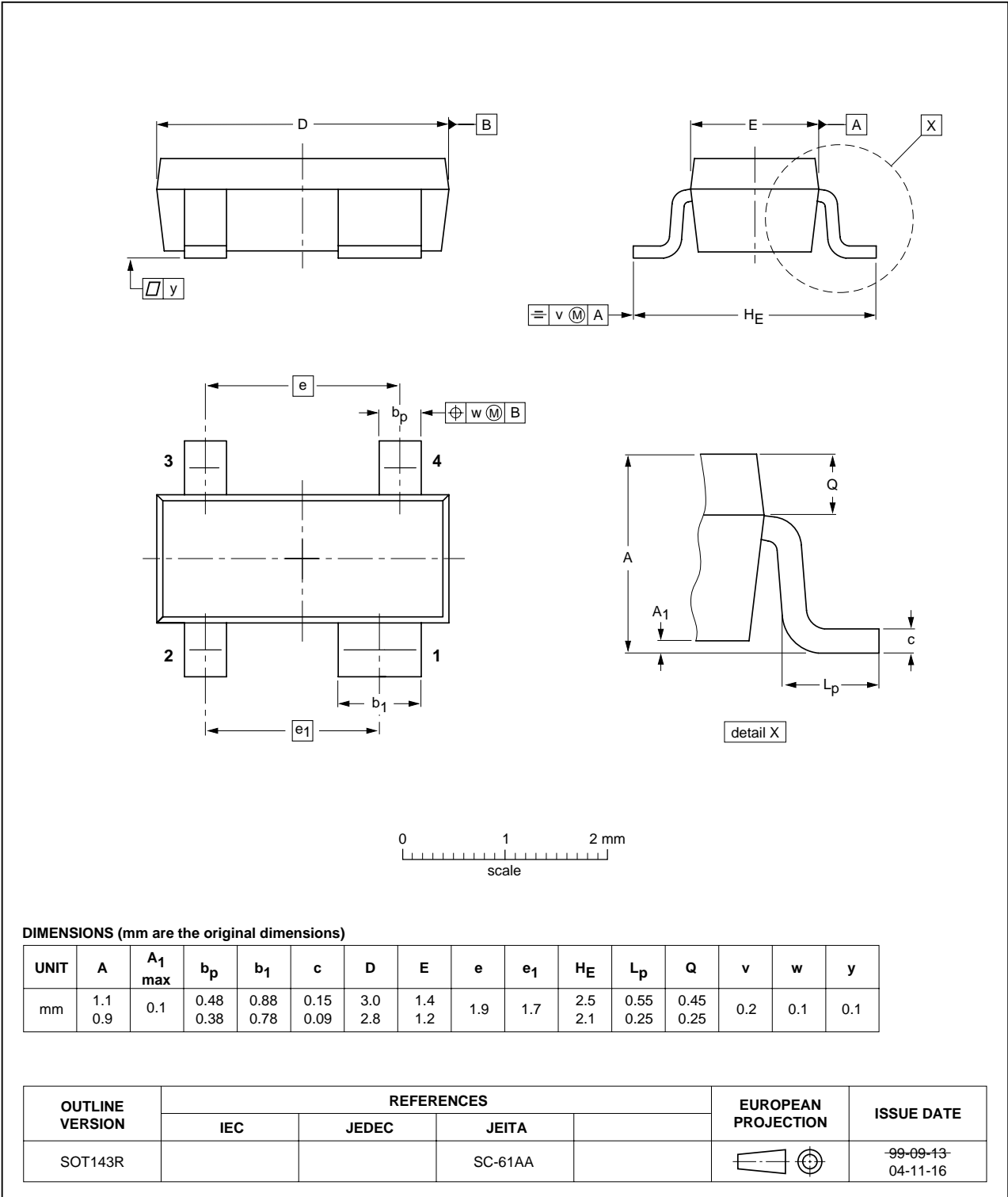

Fig 10. Package outline SOT143R (SC-61AA)



## 10. Revision history

Table 10: Revision history

Document ID	Release date	Data sheet status	Change notice	Doc. number	Supersedes
BFG310_XR_1	20050202	Product data sheet	-	9397 750 14244	-

## 11. Data sheet status

Level	Data sheet status [1]	Product status [2] [3]	Definition
I	Objective data	Development	This data sheet contains data from the objective specification for product development. Philips Semiconductors reserves the right to change the specification in any manner without notice.
II	Preliminary data	Qualification	This data sheet contains data from the preliminary specification. Supplementary data will be published at a later date. Philips Semiconductors reserves the right to change the specification without notice, in order to improve the design and supply the best possible product.
III	Product data	Production	This data sheet contains data from the product specification. Philips Semiconductors reserves the right to make changes at any time in order to improve the design, manufacturing and supply. Relevant changes will be communicated via a Customer Product/Process Change Notification (CPCN).

[1] Please consult the most recently issued data sheet before initiating or completing a design.

[2] The product status of the device(s) described in this data sheet may have changed since this data sheet was published. The latest information is available on the Internet at URL <http://www.semiconductors.philips.com>.

[3] For data sheets describing multiple type numbers, the highest-level product status determines the data sheet status.

## 12. Definitions

**Short-form specification** — The data in a short-form specification is extracted from a full data sheet with the same type number and title. For detailed information see the relevant data sheet or data handbook.

**Limiting values definition** — Limiting values given are in accordance with the Absolute Maximum Rating System (IEC 60134). Stress above one or more of the limiting values may cause permanent damage to the device. These are stress ratings only and operation of the device at these or at any other conditions above those given in the Characteristics sections of the specification is not implied. Exposure to limiting values for extended periods may affect device reliability.

**Application information** — Applications that are described herein for any of these products are for illustrative purposes only. Philips Semiconductors make no representation or warranty that such applications will be suitable for the specified use without further testing or modification.

## 13. Disclaimers

**Life support** — These products are not designed for use in life support appliances, devices, or systems where malfunction of these products can reasonably be expected to result in personal injury. Philips Semiconductors customers using or selling these products for use in such applications do so at their own risk and agree to fully indemnify Philips Semiconductors for any damages resulting from such application.

**Right to make changes** — Philips Semiconductors reserves the right to make changes in the products - including circuits, standard cells, and/or software - described or contained herein in order to improve design and/or performance. When the product is in full production (status 'Production'), relevant changes will be communicated via a Customer Product/Process Change Notification (CPCN). Philips Semiconductors assumes no responsibility or liability for the use of any of these products, conveys no license or title under any patent, copyright, or mask work right to these products, and makes no representations or warranties that these products are free from patent, copyright, or mask work right infringement, unless otherwise specified.

## 14. Contact information

For additional information, please visit: <http://www.semiconductors.philips.com>

For sales office addresses, send an email to: [sales.addresses@www.semiconductors.philips.com](mailto:sales.addresses@www.semiconductors.philips.com)

## 15. Contents

<b>1</b>	<b>Product profile</b> . . . . .	<b>1</b>
1.1	General description . . . . .	1
1.2	Features . . . . .	1
1.3	Applications . . . . .	1
1.4	Quick reference data . . . . .	1
<b>2</b>	<b>Pinning information</b> . . . . .	<b>2</b>
<b>3</b>	<b>Ordering information</b> . . . . .	<b>2</b>
<b>4</b>	<b>Marking</b> . . . . .	<b>2</b>
<b>5</b>	<b>Limiting values</b> . . . . .	<b>3</b>
<b>6</b>	<b>Thermal characteristics</b> . . . . .	<b>3</b>
<b>7</b>	<b>Characteristics</b> . . . . .	<b>3</b>
<b>8</b>	<b>Application information</b> . . . . .	<b>7</b>
<b>9</b>	<b>Package outline</b> . . . . .	<b>9</b>
<b>10</b>	<b>Revision history</b> . . . . .	<b>10</b>
<b>11</b>	<b>Data sheet status</b> . . . . .	<b>11</b>
<b>12</b>	<b>Definitions</b> . . . . .	<b>11</b>
<b>13</b>	<b>Disclaimers</b> . . . . .	<b>11</b>
<b>14</b>	<b>Contact information</b> . . . . .	<b>11</b>



© Koninklijke Philips Electronics N.V. 2005

All rights are reserved. Reproduction in whole or in part is prohibited without the prior written consent of the copyright owner. The information presented in this document does not form part of any quotation or contract, is believed to be accurate and reliable and may be changed without notice. No liability will be accepted by the publisher for any consequence of its use. Publication thereof does not convey nor imply any license under patent- or other industrial or intellectual property rights.

Date of release: 2 February 2005  
Document number: 9397 750 14244

Published in The Netherlands