

BRIGHT LED ELECTRONICS CORP.

●Device Number : BIR-BM17J4G

Page: 2

●Absolute Maximum Rating(Ta=25°C)

Version:1.1

Item	Symbol	Rating	Unit
Reverse Voltage	V _r	5	V
Reverse Current	I _r	100	μA
Power Dissipation	P _d	100	mW
Forward Current	I _f	100	mA
Peak Forward Current(*1)	I _{fp}	1.0	A
Operating Temperature	T _{opr}	-45 ~ +85	°C
Storage Temperature	T _{stg}	-45 ~ +100	°C
Soldering Temperature(*2)	T _{sol}	260	°C

(*1)、Pulse Width=10μs,10%Duty Cycle

(*2)、For 5 Sec

●Electrical And Optical Characteristics(Ta=25°C)

Parameter	Symbol	Condition	Min.	Typ.	Max.	Unit
Forward Voltage	V _f	I _f =50mA	—	1.2	1.5	V
Spectral Line Half-Width	Δλ	I _f =20mA	—	50	—	nm
Radiant Power	E _e	I _f =50mA	1.8	7.1	—	mW/cm ²
	I _e	I _f =50mA	11.7	46.8	—	mW/sr
Viewing Angle	2θ 1/2	I _f =20mA	—	20	—	deg
Peak Wavelength	λ _p	I _f =20mA	—	940	—	nm
Rise Time	T _r	I _{fp} =20mA, R _i =1kΩ	—	500	—	ns
Fall Time	T _f		—	500	—	ns

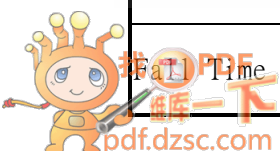

BRIGHT LED ELECTRONICS CORP.

●Device Number: BIR-BM17J4G

Page: 3

●Dimensions

Version: 1.0

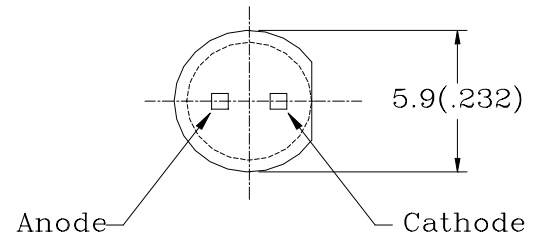
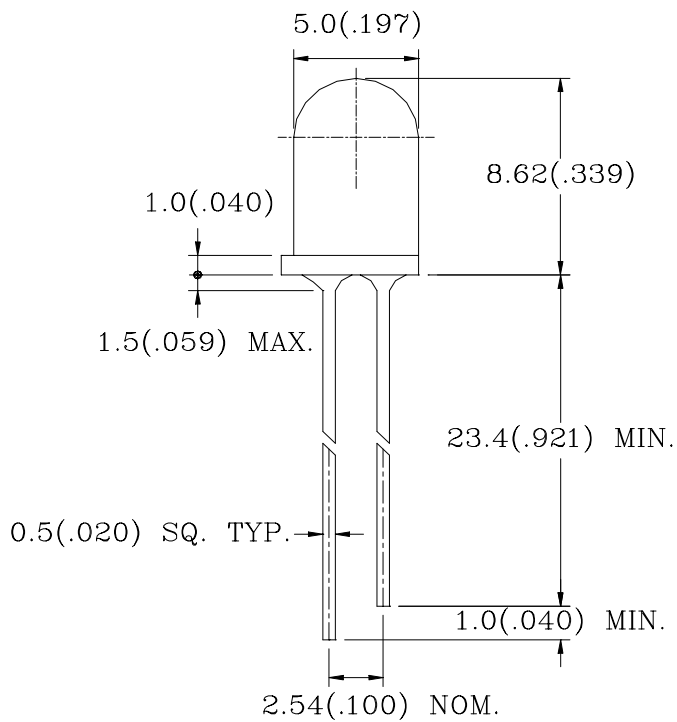

Notes:

- 1、All dimensions are in millimeters(inches).
- 2、Tolerance is $\pm 0.25\text{mm}(0.01'')$ unless otherwise specified.
- 3、Lead spacing is measured where the leads emerge from the package.
- 4、Specifications are subject to change without notice.

BRIGHT LED ELECTRONICS CORP.

●Device Number: BIR-BM17J4G

Page: 4

●Electrical And Optical Curves (Ta=25°C)

Version: 1.1

FIG.1 Spectral Distribution

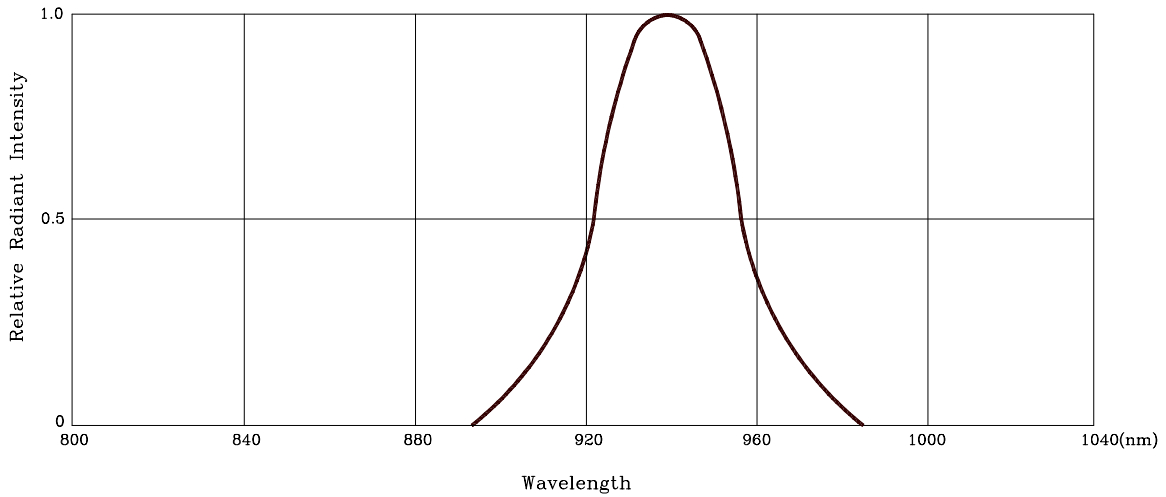

FIG.2 Forward Current Vs. Forward Voltage

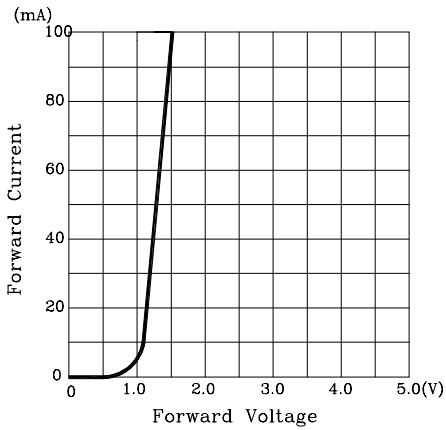

FIG.2 Relative Radiant Intensity Vs. Ambient Temperature

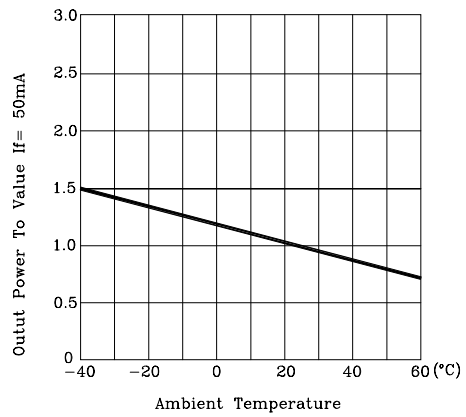

FIG.4 Relative Radiant Vs. Forward Current

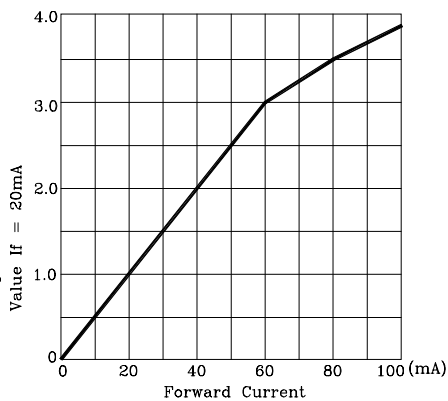

FIG.5 Radiant Diagram

