

## 5mm FLANGE BASED LED LAMP

BLF052SYC-28V-P SUPER BRIGHT YELLOW

### Features

- BUILT-IN CURRENT LIMITING RESISTOR FOR DIRECT APPLICATION OF DIFFERENT ACROSS CURRENT.
- LONG LIFE.
- LOW CURRENT, POWER SAVINGS.
- LOW MAINTENANCE.
- DIFFERENT COLOR AVAILABLE.
- SOLID STATE, HIGH VIBRATION RESISTANT.
- 28V INTERNAL RESISTOR.

### Description

The Super Bright Yellow source color devices are made with DH InGaAlP on GaAs substrate Light Emitting Diode.

### Package Dimensions

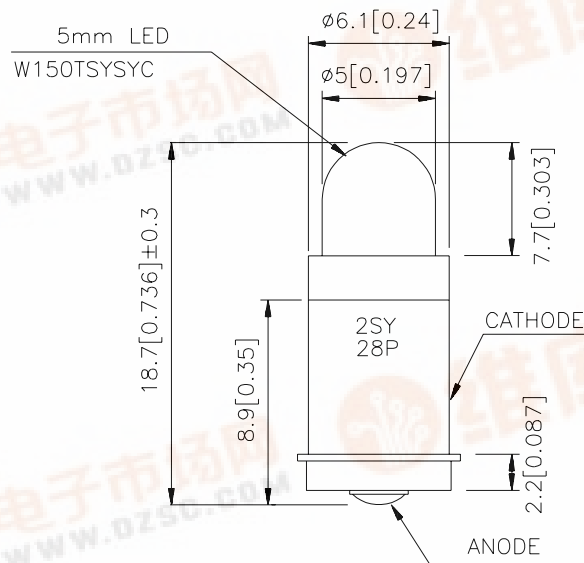

#### Notes:

1. All dimensions are in millimeters (inches).
2. Tolerance is  $\pm 0.25 (0.01")$  unless otherwise noted.
3. Specifications are subject to change without notice.

## Selection Guide

| Part No.        | Dice                         | Lens Type   | Iv (mcd)<br>V=28V |      | Viewing Angle |
|-----------------|------------------------------|-------------|-------------------|------|---------------|
|                 |                              |             | Min.              | Typ. | 2θ1/2         |
| BLF052SYC-28V-P | SUPER BRIGHT YELLOW(InGaAlP) | WATER CLEAR | 110               | 250  | 45°           |

Note:

1. θ1/2 is the angle from optical centerline where the luminous intensity is 1/2 the optical centerline value.

## Electrical / Optical Characteristics at T<sub>A</sub>=25°C

| Symbol            | Parameter                | Device              | Typ. | Max. | Units | Test Conditions     |
|-------------------|--------------------------|---------------------|------|------|-------|---------------------|
| λ <sub>peak</sub> | Peak Wavelength          | Super Bright Yellow | 590  |      | nm    | V <sub>F</sub> =12V |
| λ <sub>D</sub>    | Dominate Wavelength      | Super Bright Yellow | 588  |      | nm    | V <sub>F</sub> =12V |
| Δλ <sub>1/2</sub> | Spectral Line Half-width | Super Bright Yellow | 28   |      | nm    | V <sub>F</sub> =12V |
| I <sub>F</sub>    | Forward Current          | Super Bright Yellow | 9.6  |      | mA    | V <sub>F</sub> =12V |
| I <sub>R</sub>    | Reverse Current          | Super Bright Yellow |      | 10   | uA    | V <sub>R</sub> =5V  |

## Absolute Maximum Ratings at T<sub>A</sub>=25°C

| Parameter             | Super Bright Yellow | Units |
|-----------------------|---------------------|-------|
| Power dissipation     | 400                 | mW    |
| Forward Voltage       | 30                  | V     |
| Reverse Voltage       | 5                   | V     |
| Operating Temperature | -40 °C To + 70 °C   |       |
| Storage Temperature   | -40 °C To + 85 °C   |       |

# Kingbright

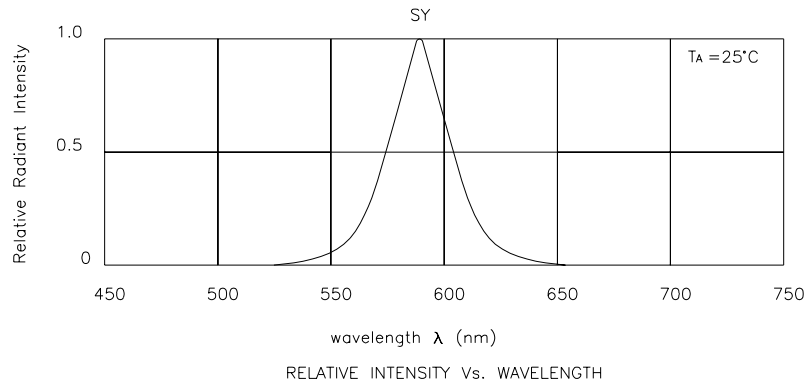

## Super Bright Yellow BLF052SYC-28V-P

