

- 抗雪崩冲击能力强
- 高速开关
- 驱动简单

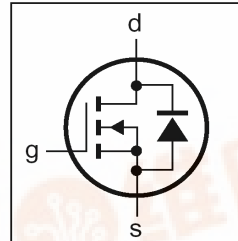

BV_{DSS}	600V
$R_{DS(ON)}$	2.2 Ω
I_D	4A

产品介绍

BLV4N60 是上海贝岭采用目前先进的工艺和设计技术, 自行开发的 600V、4A N沟 VDMOS, 适合于各类高效开关电源。

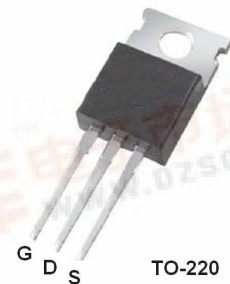

最大额定参数 (T_c=25°C 除非另有说明)

符号	参数	极限值	单位
V _{DS}	漏源电压	600	V
V _{GS}	栅源电压	± 20	V
I _D	连续漏极电流	4	A
	连续漏极电流 (T _c =100°C)	2.53	A
I _{DM}	脉冲漏极电流 (注 1)	16	A
P _D	功耗	104	W
	高于 25°C 线性降低参数	0.83	W/°C
E _{AS}	单脉冲雪崩击穿能量 (注 2)	218	mJ
I _{AR}	雪崩击穿电流	4	A
E _{AR}	重复雪崩击穿能量	10.4	mJ
T _j	工作温度范围	-55 to +150	°C
T _{SDG}	存储温度范围	-55 to +150	°C

热特性

符号	参数	极限值	单位
R _{th-jc}	热阻, 结到外壳	1.2	°C/W
R _{th-ja}	热阻, 结到环境	62.5	°C/W

电特性 (T_c=25°C 除非另有说明)

符号	参数	测试条件	最小	典型	最大	单位
BV _{DSS}	漏源击穿电压	V _{GS} =0V, I _D =250uA	600	-	-	V
ΔBV _{DSS} /ΔT _J	源漏击穿电压温度系数	Reference to 25°C I _D =250uA	-	0.6	-	V/°C
R _{DS(ON)}	导通电阻	V _{GS} =10V, I _D =2A	-	-	2.2	Ω
V _{GS(th)}	阈值电压	V _{DS} =V _{GS} , I _D =250uA	2	-	4	V
g _{fs}	跨导	V _{DS} =15V, I _D =2A(注 3)	-	3	-	S
I _{DSS}	零栅压漏电流	V _{DS} =600V, V _{GS} =0V	-	-	10	uA
	零栅压漏电流 (T _c =125°C)	V _{DS} =480V, V _{GS} =0V	-	-	100	uA
I _{GSS}	栅体漏电流	V _{GS} = ± 20V	-	-	±100	nA
Q _g	栅总电荷	V _{DD} =480V I _D =4A	-	23.7	-	nC
Q _{gs}	栅源电荷	V _{GS} =10V	-	5.4	-	nC
Q _{gd}	栅漏电荷	(注 3)	-	9.4	-	nC
t _(on)	开启延迟时间	V _{DD} =300V I _D =4A R _G =25Ω (注 3)	-	13	-	ns
t _r	开启上升时间		-	21	-	ns
t _(off)	关断延迟时间		-	35	-	ns
t _f	关断下降时间		-	25	-	ns
C _{iss}	输入电容	V _{DS} =25V	-	690	-	pF
C _{oss}	输出电容	V _{GS} =0V	-	125	-	pF
C _{rss}	反向传输电容	f = 1MHz	-	14	-	pF

源漏二极管特性

符号	参数	测试条件	最小	典型	最大	单位
I _S	连续源极电流		-	-	4	A
I _{SM}	脉冲源极电流 (注1)		-	-	16	A
V _{SD}	正向导通压降	V _{GS} =0V, I _S =4A	-	-	1.4	V
t _{rr}	反向恢复时间	V _{GS} =0V, I _S =4A (注3)	-	680	-	ns
Q _{rr}	反向恢复电荷	di _F /dt = 100A/us	-	2	-	uC

注:

- (1) Repetitive Rating: Pulse width limited by maximum junction temperature
- (2) L=25mH, I_{as}=4A, V_{dd}=50V, R_g=25Ω, starting T_j=25C
- (3) Pulse width ≤ 300 us; duty cycle ≤ 2%

Typical Characteristics

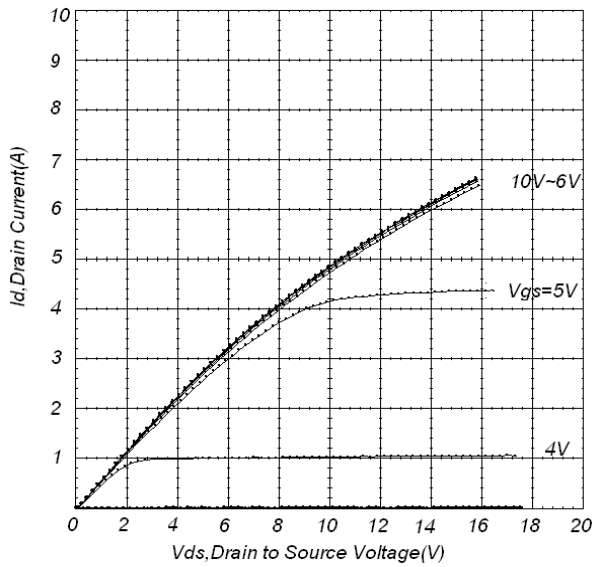

Fig 1. Typical Output Characteristics

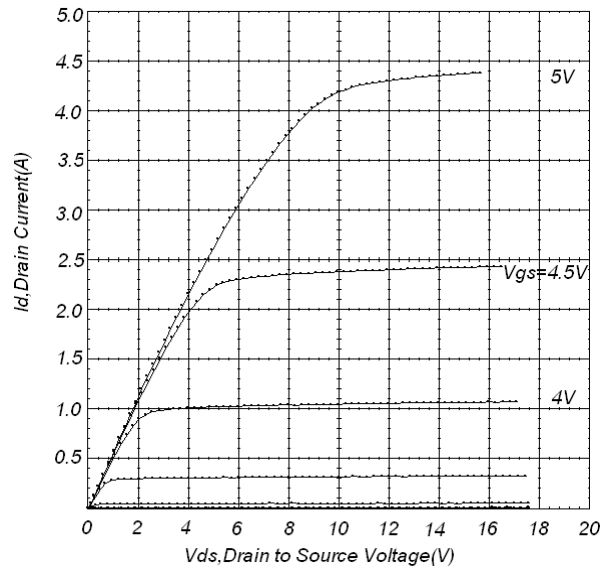

Fig 2. Typical Output Characteristics

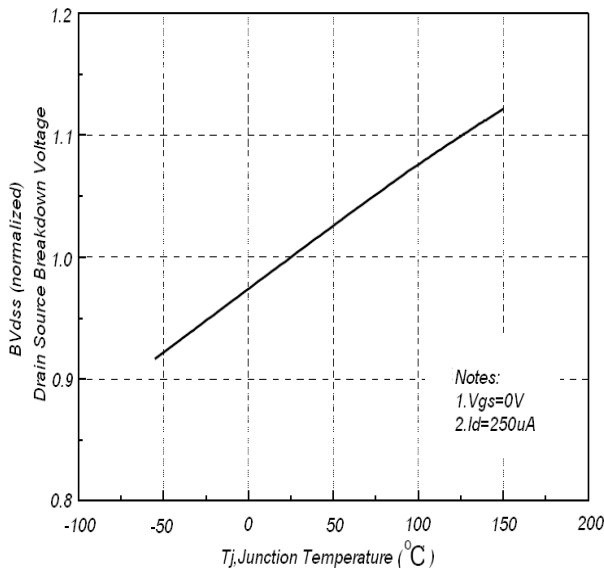

Fig 3. Normalized BV_{dss} vs. Junction Temperature

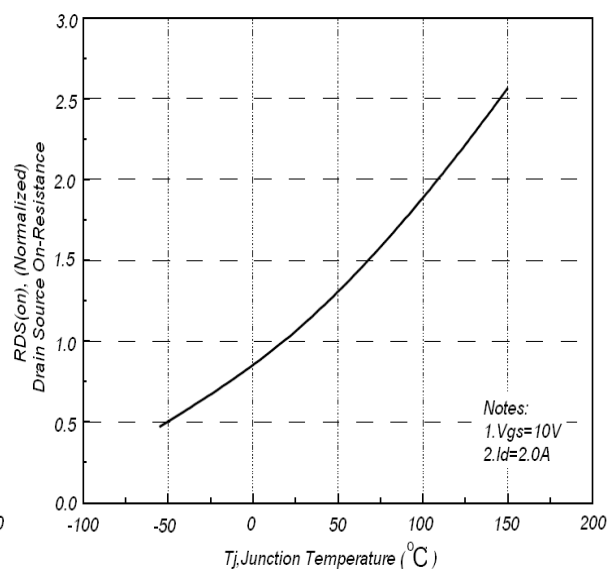

Fig 4. Normalized On-Resistance vs. Junction Temperature

Typical Characteristics (continued)

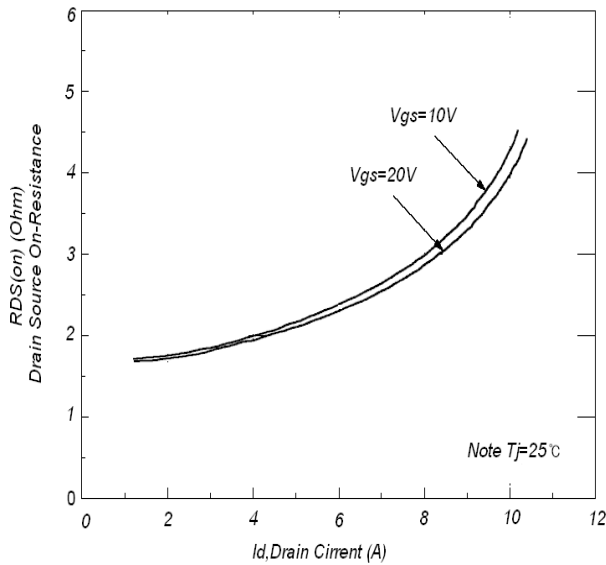

Fig 5. On-Resistance Variation vs. Drain Current and Gate Voltage

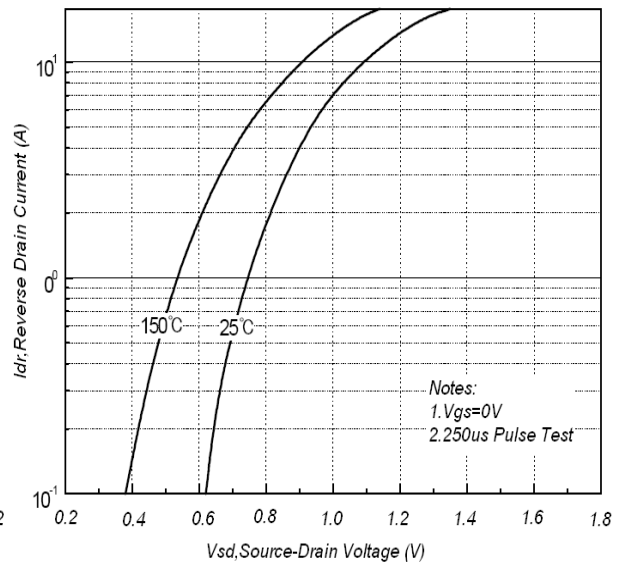

Fig 6. Body Diode Forward Voltage Variation vs. Source Current and Temperature

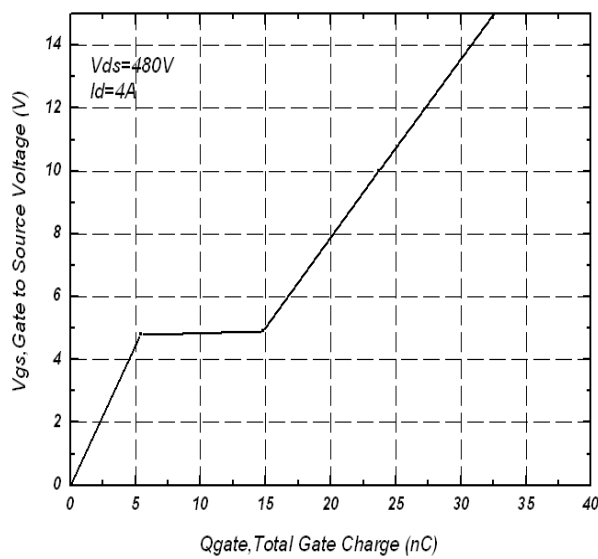

Fig 7. Gate Charge Characteristics

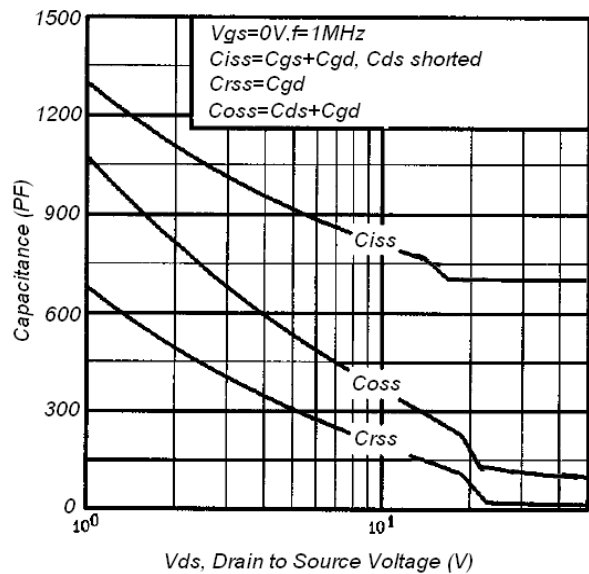

Fig 8. Capacitance Characteristics

Typical Characteristics (continued)

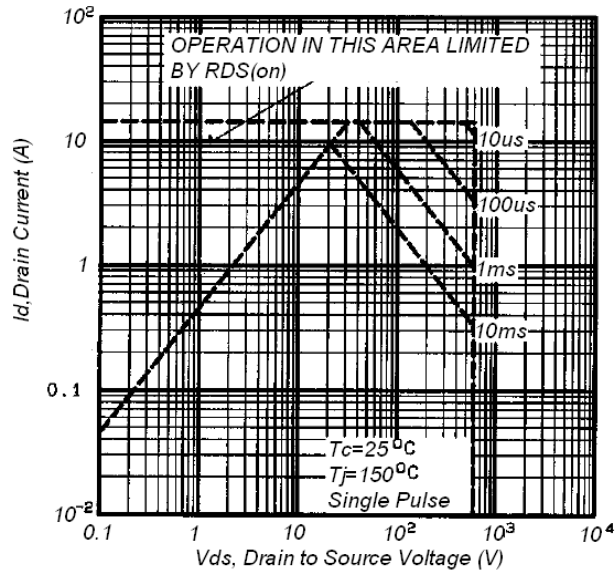

Fig 9. Maximum Safe Operating Area

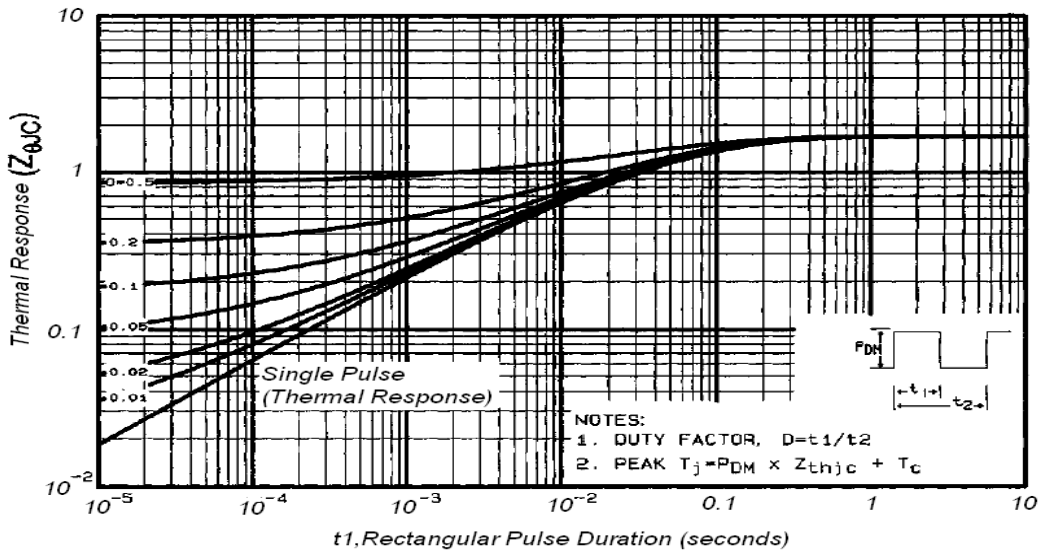

Fig 10. Transient Thermal Response Curve

Test Circuit and Waveform

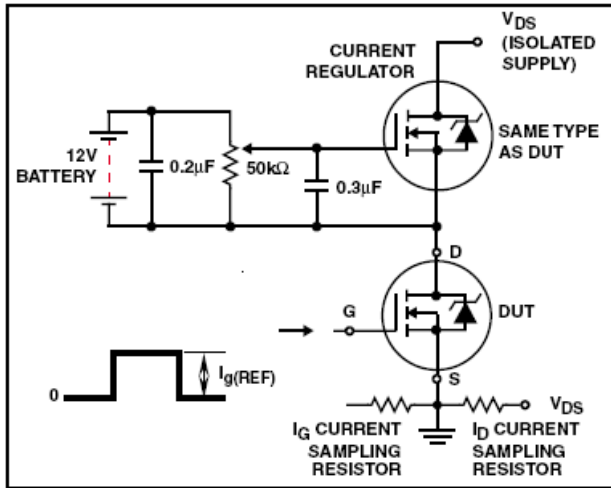

Fig 11. Gate Charge Circuit

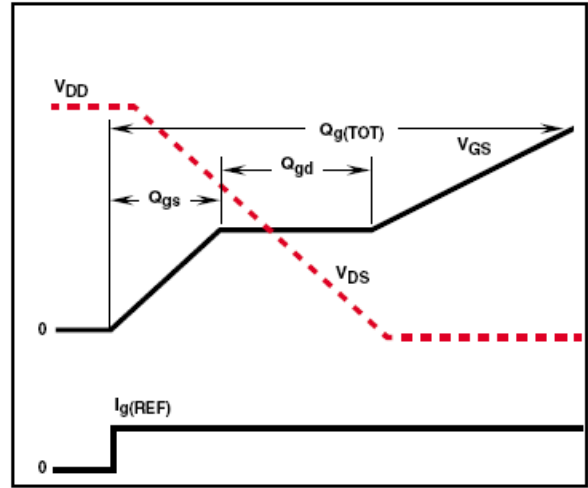

Fig 12. Gate Charge Waveform

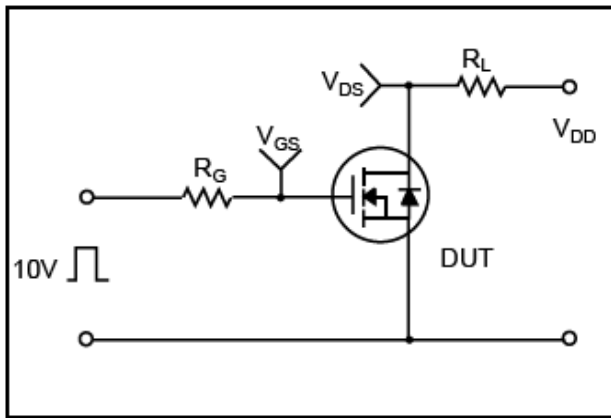

Fig 13. Switching Time Circuit

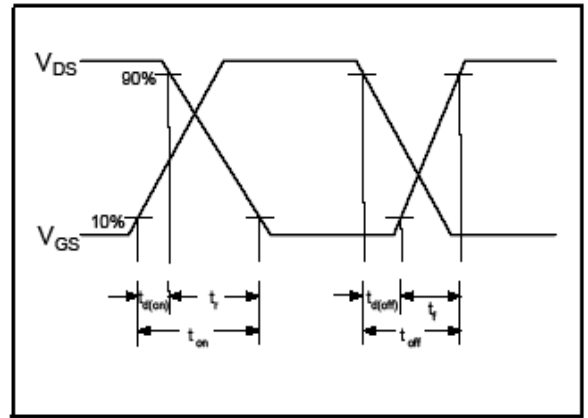

Fig 14. Switching Time Waveform

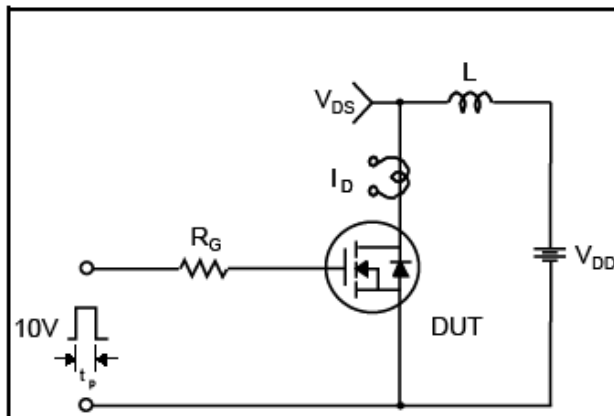

Fig 15. Unclamped Inductive Switching Test Circuit

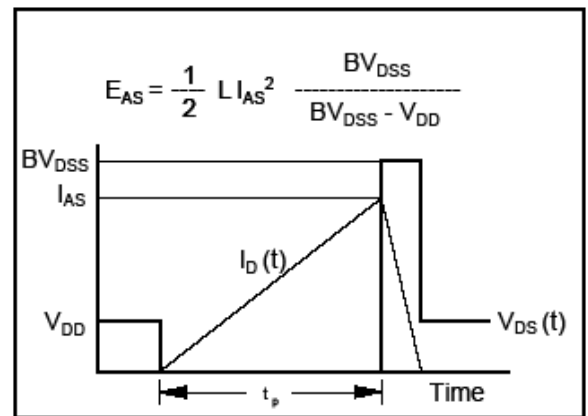

Fig 16. Unclamped Inductive Switching Waveforms