



June 2001

LM397

Single General Purpose Voltage Comparator

General Description

The LM397 is a single voltage comparator with an input common mode that includes ground. The LM397 is designed to operate from a single 5V to 30V power supply or a split power supply. Its low supply current is virtually independent of the magnitude of the supply voltage.

The LM397 features an open collector output stage. This allows the connection of an external resistor at the output. The output can directly interface with TTL, CMOS and other logic levels, by tying the resistor to different voltage levels (level translator).

The LM397 is available in space saving SOT23-5 package and pin compatible to TI's TL331, single differential comparator.

Features

($T_A = 25^\circ\text{C}$. Typical values unless otherwise specified).

- SOT23-5 package
- Industrial operating range -40°C to +85°C
- Single or dual power supplies
- Wide supply voltage range 5V to 30V
- Low supply current 300µA
- Low input bias current 7nA
- Low input offset current ±1nA
- Low input offset voltage ±2mV
- Response time 440ns (50mV overdrive)
- Input common mode voltage 0 to $V_S - 1.5V$

Applications

- A/D converters
- Pulse, square wave generators
- Peak detector
- Industrial applications

Connection Diagram

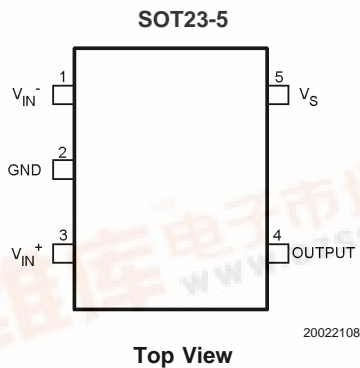

Typical Circuit

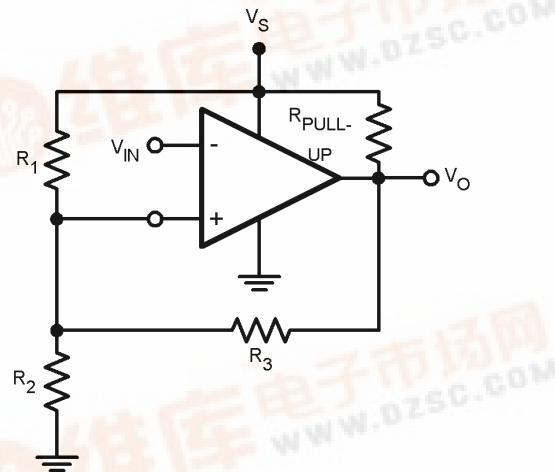

FIGURE 1. Inverting Comparator with Hysteresis

Ordering Information

Package	Part Number	Package Marking	Transport Media	NSC Drawing
5-Pin SOT-23	LM397MF	C397	1k Units Tape and Reel	MF05A
	LM397MFX		3k Units Tape and Reel	



Absolute Maximum Ratings (Note 1)

If Military/Aerospace specified devices are required, please contact the National Semiconductor Sales Office/Distributors for availability and specifications.

ESD Tolerance	
Human Body Model	2KV (Note 2)
Machine Model	200V (Note 3)
V_{IN} Differential	30V
Supply Voltages	30V or $\pm 15V$
Voltage at Input Pins	-0.3V to 30V
Storage Temperature Range	-65°C to +150°C

Junction Temperature (Note 4)	+150°C
Soldering Information	
Infrared or Convection (20 sec.)	235°C
Wave Soldering (10 sec.)	260°C

Operating Ratings (Note 1)

Supply Voltage, V_S	5V to 30V
Junction Temperature Range (Note 4)	-40°C to +85°C
Package Thermal Resistance (Note 4)	
SOT23-5	168°C/W

Electrical Characteristics

Unless otherwise specified, all limits guaranteed for at $T_J = 25^\circ\text{C}$, $V_S = 5V$. **Bold-face** limits apply at temperature extremes.

Symbol	Parameter	Conditions	Min (Note 6)	Typ (Note 5)	Max (Note 6)	Units
V_{OS}	Input Offset Voltage	$V_S = 5V$ to 30V, $V_O = 1.4V$, $V_{CM} = 0V$		2	7 10	mV
I_{OS}	Input Offset Current	$V_O = 1.4V$, $V_{CM} = 0V$		1.6	50 250	nA
I_B	Input Bias Current	$V_O = 1.4V$, $V_{CM} = 0V$		10	250 400	nA
I_S	Supply Current	$R_L = \text{Open}$, $V_S = 5V$		0.25	0.7	mA
		$R_L = \text{Open}$, $V_S = 30V$		0.30	2	
I_O	Output Sink Current	$V_{IN^+} = 1V$, $V_{IN^-} = 0V$, $V_O = 1.5V$	6	13		mA
$I_{LEAKAGE}$	Output Leakage Current	$V_{IN^+} = 1V$, $V_{IN^-} = 0V$, $V_O = 5V$		0.1		nA
		$V_{IN^+} = 1V$, $V_{IN^-} = 0V$, $V_O = 30V$		1		μA
V_{OL}	Output Voltage Low	$I_O = -4\text{mA}$, $V_{IN^+} = 0V$, $V_{IN^-} = 1V$		180	400 700	mV
V_{CM}	Common-Mode Input Voltage Range	$V_S = 5V$ to 30V (Note 7)	$V_S - 1.5V$ $V_S - 2V$		0 0	V

Electrical Characteristics Unless otherwise specified, all limits guaranteed for at $T_J = 25^\circ\text{C}$, $V_S = 5\text{V}$.
Boldface limits apply at temperature extremes. (Continued)

Symbol	Parameter	Conditions	Min (Note 6)	Typ (Note 5)	Max (Note 6)	Units
A_V	Voltage Gain	$V_S = 15\text{V}$, $V_O = 1.4\text{V}$ to 11.4V , $R_L > = 15\text{k}\Omega$ connected to V_S		120		V/mV
t_{PHL}	Propagation Delay (High to Low)	Input Overdrive = 5mV $R_L = 5.1\text{k}\Omega$ connected to 5V, $C_L = 15\text{pF}$		900		ns
		Input Overdrive = 50mV $R_L = 5.1\text{k}\Omega$ connected to 5V, $C_L = 15\text{pF}$		250		
t_{PLH}	Propagation Delay (Low to High)	Input Overdrive = 5mV $R_L = 5.1\text{k}\Omega$ connected to 5V, $C_L = 15\text{pF}$		940		μs
		Input Overdrive = 50mV $R_L = 5.1\text{k}\Omega$ connected to 5V, $C_L = 15\text{pF}$		440		ns

Note 1: Absolute Maximum Ratings indicate limits beyond which damage to the device may occur. Operating Ratings indicate conditions for which the device is intended to be functional, but specific performance is not guaranteed. For guaranteed specifications and the test conditions, see the Electrical Characteristics.

Note 2: Human body model, $1.5\text{k}\Omega$ in series with 100pF .

Note 3: Machine model, 0Ω in series with 200pF .

Note 4: The maximum power dissipation is a function of $T_{J(\text{MAX})}$, θ_{JA} , and T_A . The maximum allowable power dissipation at any ambient temperature is $P_D = (T_{J(\text{MAX})} - T_A) / \theta_{JA}$. All numbers apply for packages soldered directly onto a PC board.

Note 5: Typical values represent the most likely parametric norm.

Note 6: All limits are guaranteed by testing or statistical analysis.

Note 7: The input common-mode voltage of either input should not be permitted to go below the negative rail by more than 0.3V . The upper end of the common-mode voltage range is $V_S - 1.5\text{V}$ at 25°C .

Typical Performance Characteristics $T_A = 25^\circ\text{C}$. Unless otherwise specified.

Supply Current vs. Supply Voltage

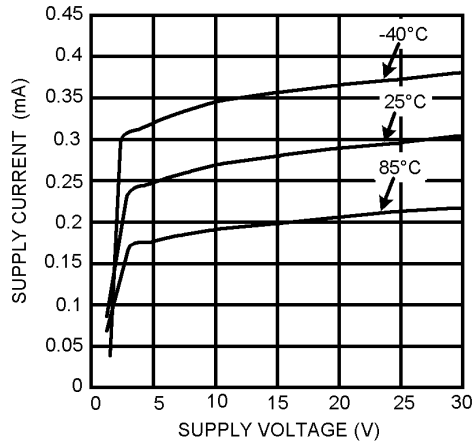

Input Bias Current vs. Supply Current

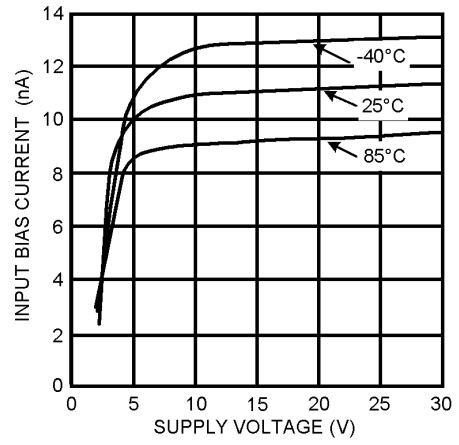

Output Saturation Voltage vs. Output Sink Current

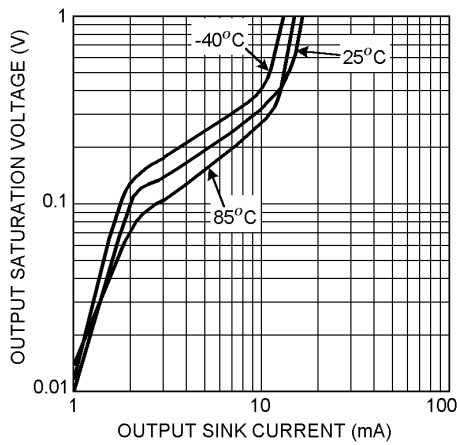

Input Offset Voltage vs. Supply Voltage

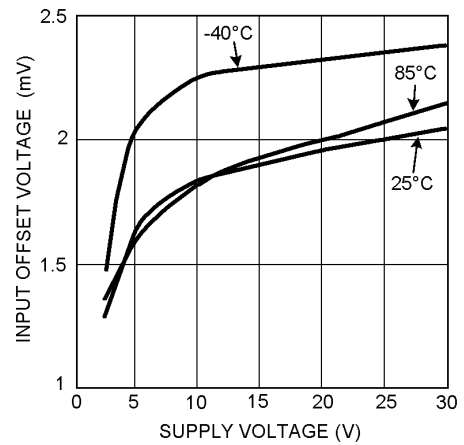

Response Time for Various Input Overdrives – t_{PHL}

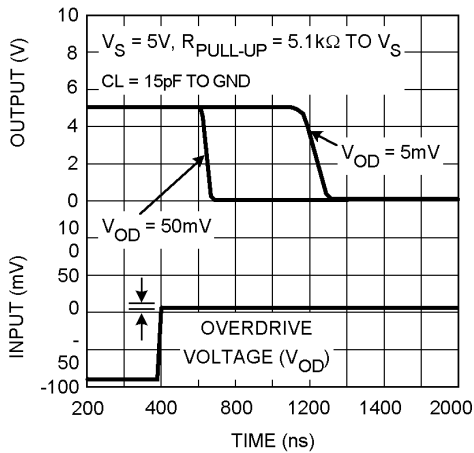

Response Time for Various Input Overdrives – t_{PLH}

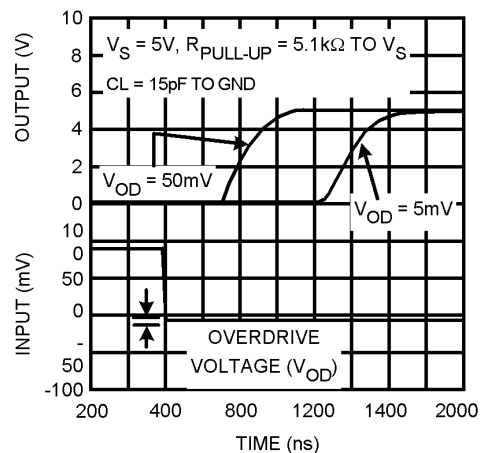

Application Notes

Basic Comparators

A comparator is quite often used to convert an analog signal to a digital signal. The comparator compares an input voltage (V_{IN}) at the non-inverting pin to the reference voltage (V_{REF}) at the inverting pin. If V_{IN} is less than V_{REF} the output (V_O) is low (V_{OL}). However, if V_{IN} is greater than V_{REF} , the output voltage (V_O) is high (V_{OH}). Refer to *Figure 2*.

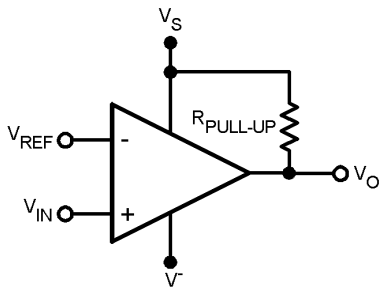

20022110

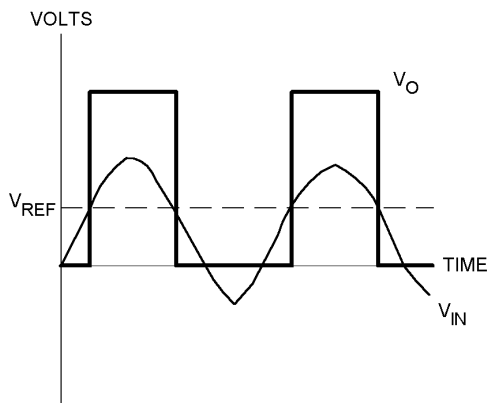

20022111

FIGURE 2. Basic Comparator

Hysteresis

The basic comparator configuration may oscillate or produce a noisy output if the applied differential input is near the comparator's input offset voltage. This tends to occur when the voltage on the input is equal or very close to the other input voltage. Adding hysteresis can prevent this problem. Hysteresis creates two switching thresholds (one for the rising input voltage and the other for the falling input voltage). Hysteresis is the voltage difference between the two switching thresholds. When both inputs are nearly equal, hysteresis causes one input to effectively move quickly pass the other. Thus, effectively moving the input out of region that oscillation may occur.

For an inverting configured comparator, hysteresis can be added with a three resistor network and positive feedback. When input voltage (V_{IN}) at the inverting node is less than non-inverting node (V_T), the output is high. The equivalent circuit for the three resistor network is R_1 in parallel with R_3 and in series with R_2 . The lower threshold voltage V_{T1} is calculated by:

$$V_{T1} = ((V_S R_2) / (((R_1 R_3) / (R_1 + R_3)) + R_2))$$

When V_{IN} is greater than V_T , the output voltage is low. The equivalent circuit for the three resistor network is R_2 in parallel with R_3 and in series with R_1 . The upper threshold voltage V_{T2} is calculated by:

$$V_{T2} = V_S ((R_2 R_3) / (R_2 + R_3)) / (R_1 + ((R_2 R_3) / (R_2 + R_3)))$$

The hysteresis is defined as

$$\Delta V_{IN} = V_{T1} - V_{T2}$$

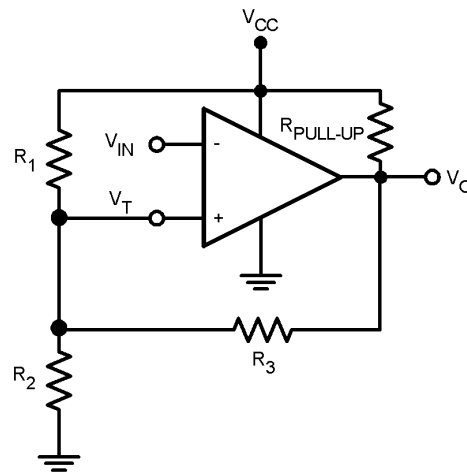

20022112

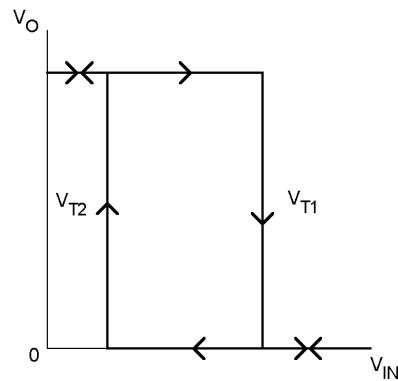

20022113

FIGURE 3. Inverting Configured Comparator – LM397

Application Notes (Continued)

Input Stage

The LM397 has a bipolar input stage. The input common mode voltage range is from 0 to $(V_S - 1.5V)$.

Output Stage

The LM397 has an open collector grounded-emitter NPN output transistor for the output stage. This requires an external pull-up resistor connected between the positive supply voltage and the output. The external pull-up resistor should be high enough resistance so to avoid excessive power dissipation. In addition, the pull-up resistor should be low enough resistance to enable the comparator to switch with the load circuitry connected. Because it is an open collector output stage, several comparator outputs can be connected together to create an OR'ing function output. With an open collector, the output can be used as a simple SPST switch to ground. The amount of current which the output can sink is approximately 10mA. When the maximum current limit is reached, the output transistor will saturate and the output will rise rapidly (*Figure 4*).

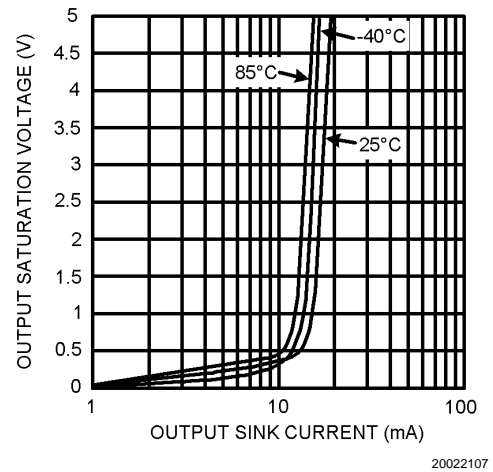

20022107

FIGURE 4. Output Saturation Voltage vs. Output Sink Current

SOT23-5 Tape and Reel Specification

Tape Format

Tape Section	# Cavities	Cavity Status	Cover Tape Status
Leader (Start End)	0 (min)	Empty	Sealed
	75 (min)	Empty	Sealed
Carrier	3000	Filled	Sealed
	1000	Filled	Sealed
Trailer (Hub End)	125 (min)	Empty	Sealed
	0 (min)	Empty	Sealed

TAPE DIMENSIONS

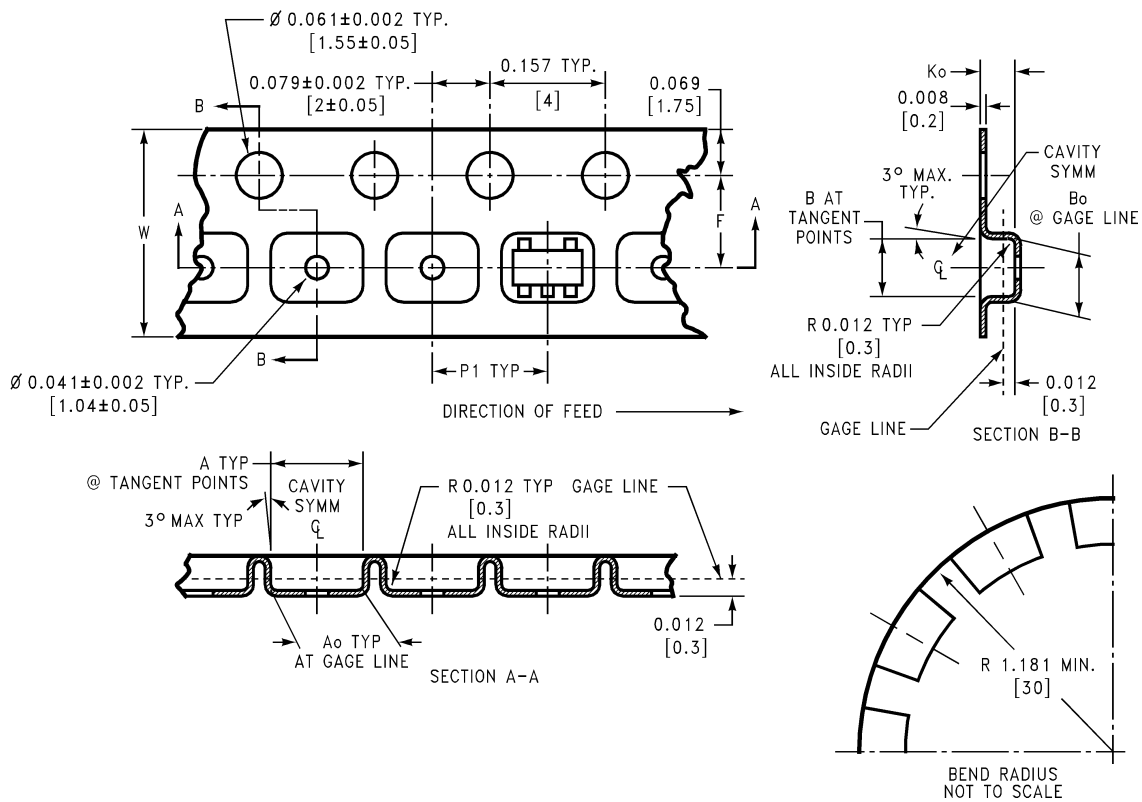

20022115

8mm	0.130 (3.3)	0.124 (3.15)	0.130 (3.3)	0.126 (3.2)	0.138 ± 0.002 (3.5 ± 0.05)	0.055 ± 0.004 (1.4 ± 0.11)	0.157 (4)	0.315 ± 0.012 (8 ± 0.3)
Tape Size	DIM A	DIM A ₀	DIM B	DIM B ₀	DIM F	DIM K ₀	DIM P1	DIM W

SOT23-5 Tape and Reel Specification (Continued)

REEL DIMENSIONS

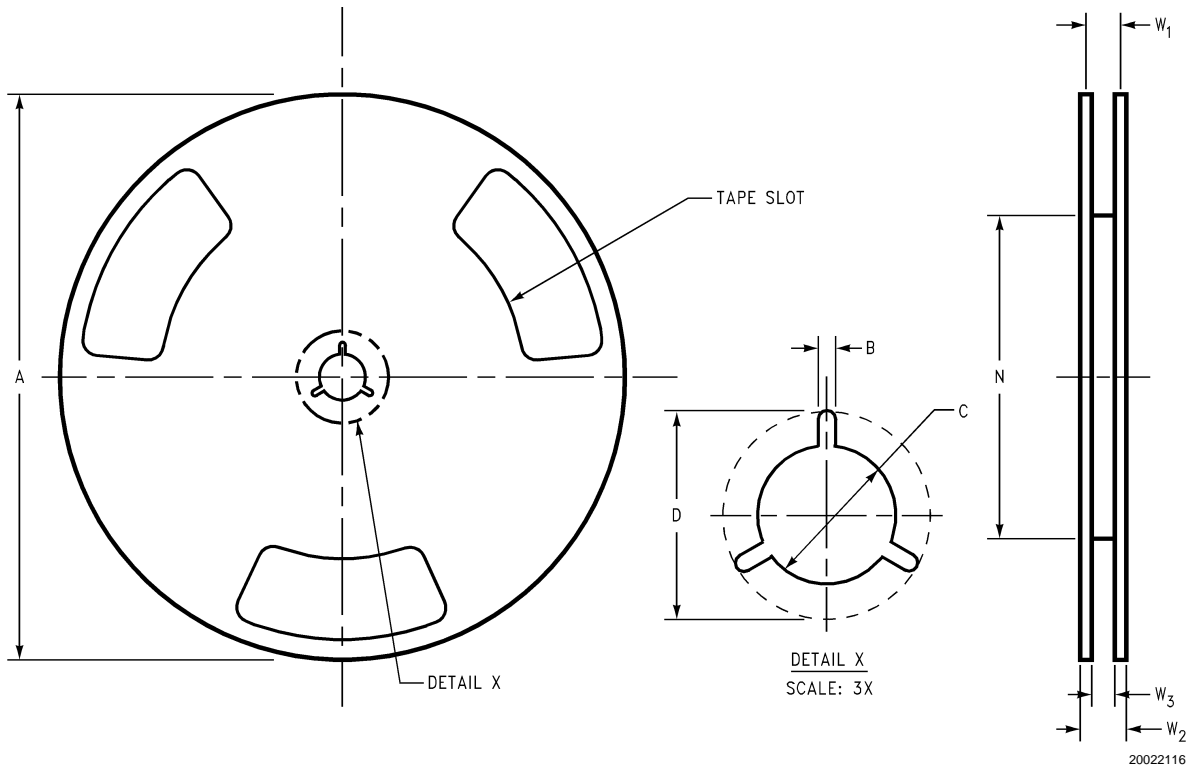

8mm	7.00 330.00	0.059 1.50	0.512 13.00	0.795 20.20	2.165 55.00	$0.331 + 0.059/-0.000$ $8.40 + 1.50/-0.00$	0.567 14.40	$W1 + 0.078/-0.039$ $W1 + 2.00/-1.00$
Tape Size	A	B	C	D	N	W1	W2	W3

Physical Dimensions inches (millimeters) unless otherwise noted

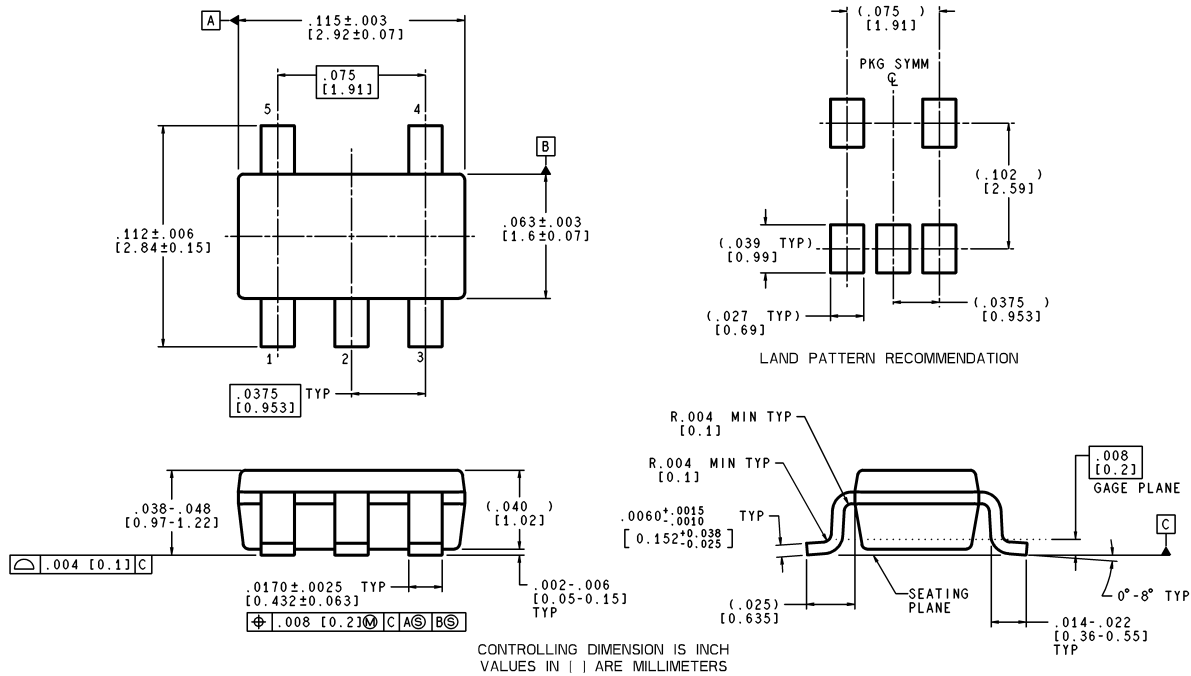

MF05A (Rev A)

**5-Pin SOT23
NS Package Number MF05A**

LIFE SUPPORT POLICY

NATIONAL'S PRODUCTS ARE NOT AUTHORIZED FOR USE AS CRITICAL COMPONENTS IN LIFE SUPPORT DEVICES OR SYSTEMS WITHOUT THE EXPRESS WRITTEN APPROVAL OF THE PRESIDENT AND GENERAL COUNSEL OF NATIONAL SEMICONDUCTOR CORPORATION. As used herein:

1. Life support devices or systems are devices or systems which, (a) are intended for surgical implant into the body, or (b) support or sustain life, and whose failure to perform when properly used in accordance with instructions for use provided in the labeling, can be reasonably expected to result in a significant injury to the user.
2. A critical component is any component of a life support device or system whose failure to perform can be reasonably expected to cause the failure of the life support device or system, or to affect its safety or effectiveness.



National Semiconductor Corporation
Americas
Email: support@nsc.com

www.national.com

National Semiconductor Europe

Fax: +49 (0) 180-530 85 86
Email: europe.support@nsc.com
Deutsch Tel: +49 (0) 69 9508 6208
English Tel: +44 (0) 870 24 0 2171
Français Tel: +33 (0) 1 41 91 8790

National Semiconductor Asia Pacific Customer Response Group

Tel: 65-2544466
Fax: 65-2504466
Email: ap.support@nsc.com

National Semiconductor Japan Ltd.

Tel: 81-3-5639-7560
Fax: 81-3-5639-7507