



DDA (LO-R1) U

PNP PRE-BIASED SMALL SIGNAL SOT-363 DUAL SURFACE MOUNT TRANSISTOR

NEW PRODUCT

Features

- Epitaxial Planar Die Construction
- Complementary NPN Types Available (DDC)
- Built-In Biasing Resistors
- Lead-Free/RoHS Compliant (Note 3)

Mechanical Data

- Case: SOT-363
- Case Material: Molded Plastic, UL Flammability Classification Rating 94V-0
- Moisture Sensitivity: Level 1 per J-STD-020C
- Terminals: Finish - Matte Tin Solderable per MIL-STD-202, Method 208
- Lead Free Plating (Matte Tin Finish annealed over Alloy 42 leadframe).
- Terminal Connections: See Diagram
- Marking: Date Code and Marking Code (See Diagrams & Page 2)
- Ordering Information (See Page 2)
- Weight: 0.006 grams (approx.)

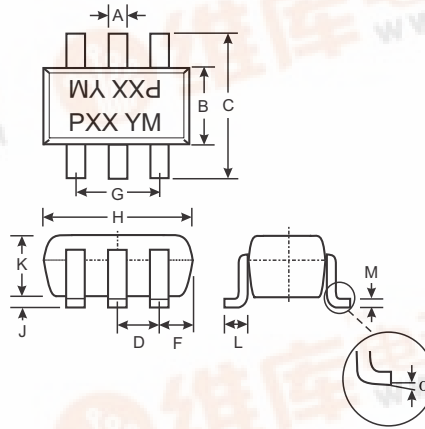

SOT-363		
Dim	Min	Max
A	0.10	0.30
B	1.15	1.35
C	2.00	2.20
D	0.65 Nominal	
F	0.30	0.40
H	1.80	2.20
J	—	0.10
K	0.90	1.00
L	0.25	0.40
M	0.10	0.25
α	0°	8°
All Dimensions in mm		

P/N	R1 (NOM)	R2 (NOM)	MARKING
DDA122LU	0.22K	10K	P81
DDA142JU	0.47K	10K	P82
DDA122TU	0.22K	OPEN	P83
DDA142TU	0.47K	OPEN	P84

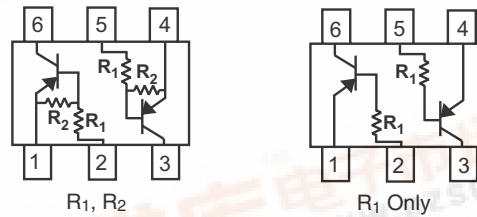

SCHEMATIC DIAGRAM

Maximum Ratings @ T_A = 25°C unless otherwise specified

Characteristic	Symbol	Value	Unit
Supply Voltage (1) to (6) and (4) to (3)	V _{CC}	-50	V
Input Voltage (1) to (2) and (4) to (5)	V _{IN}	+5 to -6	V
Input Voltage (1) to (2) and (4) to (5)	V _{EBO (MAX)}	-5	V
Output Current	I _C	-100	mA
Power Dissipation (Note 2)	P _d	200	mW
Thermal Resistance, Junction to Ambient Air (Note 2)	R _{θJA}	625	°C/W
Operating and Storage and Temperature Range	T _j , T _{STG}	-55 to +150	°C

- Note:
1. Mounted on FR4 PC Board with recommended pad layout at <http://www.diodes.com/datasheets/ap02001.pdf>.
 2. 150mW per element must not be exceeded.
 3. No purposefully added lead.



Electrical Characteristics @ T_A = 25°C unless otherwise specified **R1, R2 Types**

Characteristic		Symbol	Min	Typ	Max	Unit	Test Condition
Input Voltage	DDA122LU DDA142JU	V _{I(off)}	-0.3 -0.3	—	—	V	V _{CC} = -5V, I _O = -100μA
	DDA122LU DDA142JU	V _{I(on)}	—	—	-2.0 -2.0	V	V _O = -0.3V, I _O = -20mA V _O = -0.3V, I _O = -20mA
Output Voltage		V _{O(on)}	—	—	-0.3V	V	I _O /I _I = -5mA/-0.25mA
Input Current	DDA122LU DDA142JU	I _I	—	—	-28 -13	mA	V _I = -5V
Output Current		I _{O(off)}	—	—	-0.5	μA	V _{CC} = -50V, V _I = 0V
DC Current Gain	DDA122LU DDA142JU	G _I	56 56	—	—	—	V _O = -5V, I _O = -10mA
Gain-Bandwidth Product*		f _T	—	200	—	MHz	V _{CE} = -10V, I _E = -5mA, f = 100MHz

* Transistor - For Reference Only

Electrical Characteristics @ T_A = 25°C unless otherwise specified **R1 Only Types**

Characteristic		Symbol	Min	Typ	Max	Unit	Test Condition
Collector-Base Breakdown Voltage		BV _{CBO}	-50	—	—	V	I _C = -50μA
Collector-Emitter Breakdown Voltage		BV _{CEO}	-40	—	—	V	I _C = -1mA
Emitter-Base Breakdown Voltage	DDA122TU DDA142TU	BV _{EBO}	-5	—	—	V	I _E = -50μA I _E = -50μA
Collector Cutoff Current		I _{CBO}	—	—	-0.5	μA	V _{CB} = -50V
Emitter Cutoff Current	DDA122TU DDA142TU	I _{EBO}	—	—	-0.5 -0.5	μA	V _{EB} = -4V
Collector-Emitter Saturation Voltage		V _{CE(sat)}	—	—	-0.3	V	I _C = -5mA, I _B = -0.25mA
DC Current Transfer Ratio	DDA122TU DDA142TU	h _{FE}	100 100	250 250	600 600	—	I _C = -1mA, V _{CE} = -5V
Gain-Bandwidth Product*		f _T	—	200	—	MHz	V _{CE} = -10V, I _E = 5mA, f = 100MHz

* Transistor - For Reference Only

Ordering Information (Note 4)

Device	Packaging	Shipping
DDA122LU-7-F	SOT-363	3000/Tape & Reel
DDA142JU-7-F	SOT-363	3000/Tape & Reel
DDA122TU-7-F	SOT-363	3000/Tape & Reel
DDA142TU-7-F	SOT-363	3000/Tape & Reel

Notes: 4. For Packaging Details, go to our website at <http://www.diodes.com/datasheets/ap02007.pdf>.

Marking Information

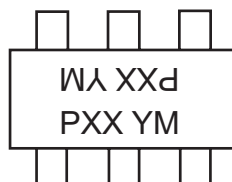

PXX = Product Type Marking Code
See Sheet 1 Diagrams
YM = Date Code Marking
Y = Year ex: T = 2006
M = Month ex: 9 = September

Date Code Key

Year	2006	2007	2008	2009	2010	2011	2012
Code	T	U	V	W	X	Y	Z

Month	Jan	Feb	Mar	Apr	May	Jun	Jul	Aug	Sep	Oct	Nov	Dec
Code	1	2	3	4	5	6	7	8	9	O	N	D

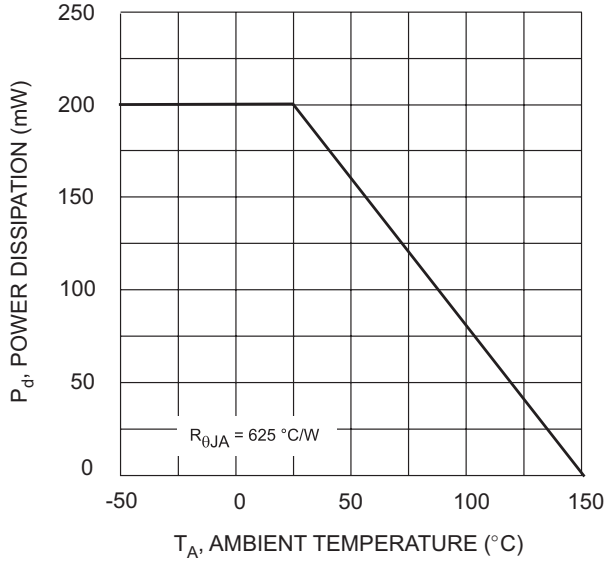

Fig. 1 Power Derating Curve

(150mW per element must not be exceeded).

IMPORTANT NOTICE

Diodes Incorporated and its subsidiaries reserve the right to make modifications, enhancements, improvements, corrections or other changes without further notice to any product herein. Diodes Incorporated does not assume any liability arising out of the application or use of any product described herein; neither does it convey any license under its patent rights, nor the rights of others. The user of products in such applications shall assume all risks of such use and will agree to hold Diodes Incorporated and all the companies whose products are represented on our website, harmless against all damages.

LIFE SUPPORT

Diodes Incorporated products are not authorized for use as critical components in life support devices or systems without the expressed written approval of the President of Diodes Incorporated.