



DG381B/384B/387B/390B

Vishay Siliconix

CMOS Analog Switches

FEATURES

- ± 15-V Input Range
- Low $r_{DS(on)}$: 30 Ω
- Single Supply Operation
- Pin and Function Compatible with the JFET DG180 Family

BENEFITS

- Full Rail-to-Rail Analog Signal Range
- Minimizes Signal Error
- Low Power Dissipation

APPLICATIONS

- Low Level Switching Circuits
- Programmable Gain Amplifiers
- Portable and Battery Powered Systems

DESCRIPTION

The DG381B–DG390B series of monolithic CMOS analog switches was designed for applications in instrumentation, communications, and process control. This series is suited for applications requiring fast switching and nearly flat on-resistance over the entire voltage range.

switches are ideal for battery powered applications, without sacrificing switching speed. Break-before-make switching action is guaranteed, and an epitaxial layer prevents latchup. Single supply operation is allowed by connecting the V– rail to 0 V.

Designed on Vishay Siliconix' PLUS-40 CMOS process, these devices achieve low power consumption (3.5 mW typical) and excellent on/off switch performance. These

Each switch conducts equally well in both directions when on, and blocks up to the supply voltage when off. These switches are CMOS and quasi TTL logic compatible.

FUNCTIONAL BLOCK DIAGRAM AND PIN CONFIGURATION

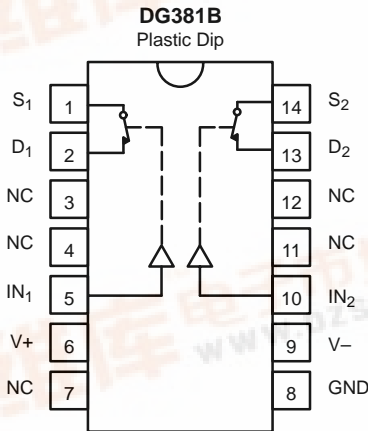

Top View

TRUTH TABLE	
Logic	Switch
0	ON
1	OFF

Logic "0" \leq 0.8 V
 Logic "1" \geq 4 V



DG381B/384B/387B/390B

Vishay Siliconix



FUNCTIONAL BLOCK DIAGRAM AND PIN CONFIGURATION

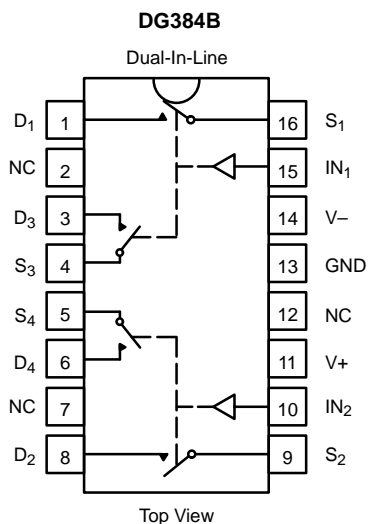

TRUTH TABLE	
Logic	Switch
0	OFF
1	ON

Logic "0" ≤ 0.8 V
Logic "1" ≥ 4 V

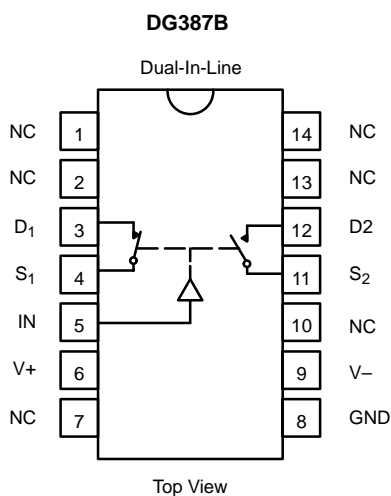

TRUTH TABLE		
Logic	SW ₁	SW ₂
0	ON	OFF
1	OFF	ON

Logic "0" ≤ 0.8 V
Logic "1" ≥ 4 V

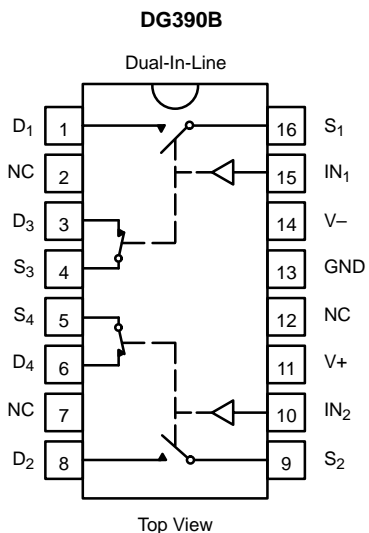

TRUTH TABLE		
Logic	SW ₁ , SW ₂	SW ₃ , SW ₄
0	OFF	ON
1	ON	OFF

Logic "0" ≤ 0.8 V
Logic "1" ≥ 4 V



ORDERING INFORMATION		
Temp Range	Package	Part Number
DG381B		
-40 to 85°C	14-Pin Plastic DIP	DG381BDJ
DG384B		
-40 to 85°C	16-Pin Plastic DIP	DG384BDJ
DG387B		
-40 to 85°C	14-Pin Plastic DIP	DG387BDJ
DG390B		
-40 to 85°C	16-Pin Plastic DIP	DG390BDJ

ABSOLUTE MAXIMUM RATINGS

Voltages Referenced to V-
 V+ 44 V
 GND 25 V
 Digital Inputs^a, V_S, V_D (V-) -2 V to (V+) +2V or 30 mA, whichever occurs first
 Current, Any Terminal Except S or D 30 mA
 Continuous Current, S or D 30 mA
 (Pulsed at 1 ms, 10% duty cycle max) 100 mA

Storage Temperature -65 to 150°C
 Power Dissipation^b
 14-Pin Plastic DIP^d 470 mW

- Notes:
 a. Signals on S_X, D_X, or IN_X exceeding V+ or V- will be clamped by internal diodes. Limit forward diode current to maximum current ratings.
 b. All leads welded or soldered to PC Board.
 c. Derate 11 mW/°C above 75°C
 d. Derate 6.5 mW/°C above 25°C

SCHEMATIC DIAGRAM (TYPICAL CHANNEL)

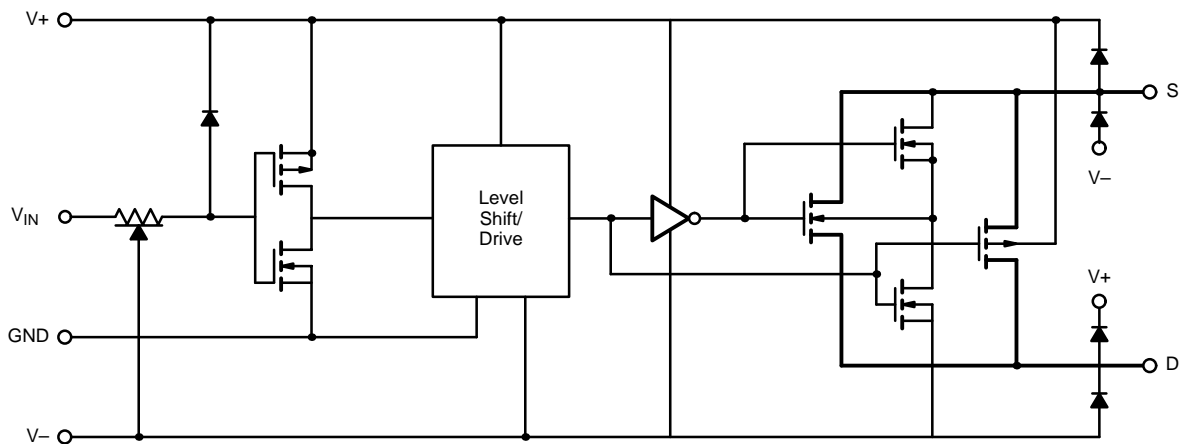

FIGURE 1.

DG381B/384B/387B/390B



Vishay Siliconix

SPECIFICATIONS ^a							
Parameter	Symbol	Test Conditions Unless Specified $V_+ = 15\text{ V}$, $V_- = -15\text{ V}$ $V_{IN} = 0.8\text{ V}$ or 4 V^f	Temp ^b	Limits -40 to 85°C			Unit
				Min ^d	Typ ^c	Max ^d	
Analog Switch							
Analog Signal Range ^e	V_{ANALOG}		Full	-15		15	V
Drain-Source On-Resistance	$r_{DS(on)}$	$V_D = \pm 10\text{ V}$, $I_S = -10\text{ mA}$	Room Full		30	50 75	Ω
Source Off Leakage Current	$I_{S(off)}$	$V_S = \pm 14\text{ V}$, $V_D = \mp 14\text{ V}$	Room Hot	-5 -100	± 0.1	5 100	nA
Drain Off Leakage Current	$I_{D(off)}$	$V_S = \pm 14\text{ V}$, $V_D = \mp 14\text{ V}$	Room Hot	-5 -100	± 0.1	5 100	
Drain On Leakage Current	$I_{D(on)}$	$V_D = V_S = \pm 14\text{ V}$	Room Hot	-5 -100	± 0.1	5 100	
Digital Control							
Input Current with Input Voltage High	I_{INH}	$V_{IN} = 5\text{ V}$	Room Full	-1	-0.001		μA
		$V_{IN} = 15\text{ V}$	Room Full		0.001	1	
Input Current with Input Voltage Low	I_{INL}	$V_{IN} = 0\text{ V}$	Room Full	-1	-0.001		
Dynamic Characteristics							
Turn-On Time	t_{ON}	See Figure 2	Room		150		ns
Turn-Off Time	t_{OFF}		Room		130		
Break-Before-Make Time	t_{OPEN}	See Figure 3	Room		50		
Charge Injection	Q	$C_L = 0.01\ \mu\text{F}$, $R_{gen} = 0\ \Omega$, $V_{gen} = 0\text{ V}$	Room		10		pC
Source-Off Capacitance	$C_{S(off)}$	$f = 1\text{ MHz}$; V_S , $V_D = 0\text{ V}$	Room		14		pF
Drain-Off Capacitance	$C_{D(off)}$		Room		14		
Channel-On Capacitance	$C_{D(on)}$		Room		40		
Input Capacitance	C_{IN}		$f = 1\text{ MHz}$	$V_{IN} = 0\text{ V}$	Room		
		$V_{IN} = 15\text{ V}$		Room		7	
Off-Isolation	OIRR	$V_{IN} = 0\text{ V}$, $R_L = 1\text{ k}\Omega$ $V_S = 1\text{ V}_{rms}$, $f = 500\text{ kHz}$	Room		62		dB
Crosstalk (Channel-to-Channel)	XTALK		Room		74		
Power Supplies							
Positive Supply Current	I+	$V_{IN} = 4\text{ V}$ (One Input) (All Others = 0)	Room Full		0.23	1	mA
Negative Supply Current	I-		Room Full	-100	-0.001		
Positive Supply Current	I+	$V_{IN} = 0.8\text{ V}$ (All Inputs)	Room Full		0.001	100	μA
Negative Supply Current	I-		Room Full	-100	-0.001		

Notes:

- Refer to PROCESS OPTION FLOWCHART.
- Room = 25°C, Full = as determined by the operating temperature suffix.
- Typical values are for DESIGN AID ONLY, not guaranteed nor subject to production testing.
- The algebraic convention whereby the most negative value is a minimum and the most positive a maximum, is used in this data sheet.
- Guaranteed by design, not subject to production test.
- V_{IN} = input voltage to perform proper function.



TYPICAL CHARACTERISTICS (25°C UNLESS NOTED)

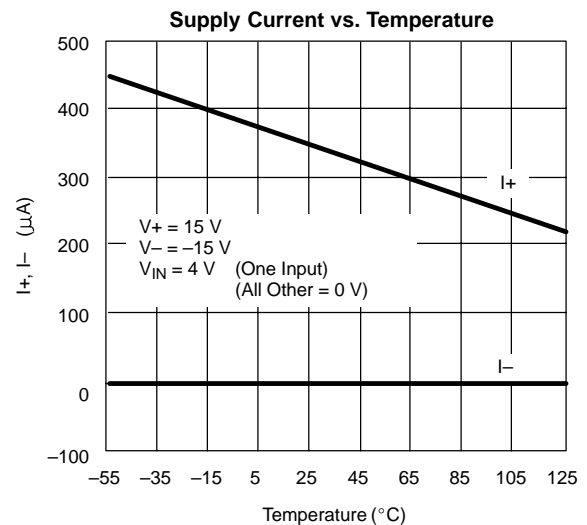
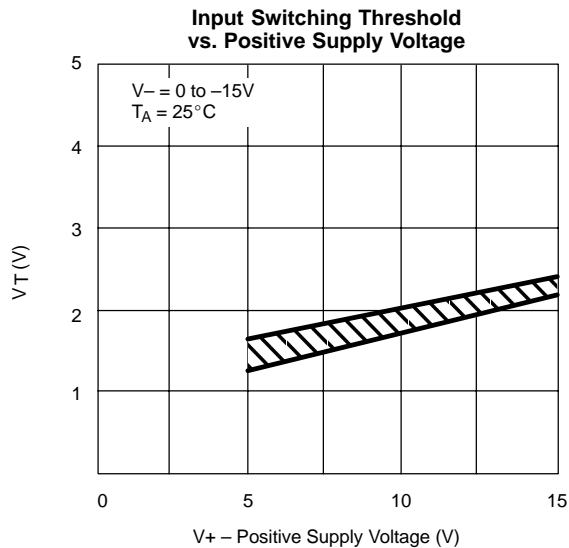
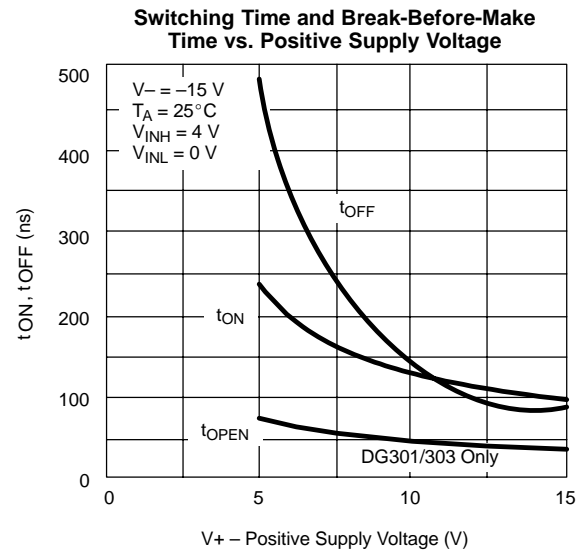
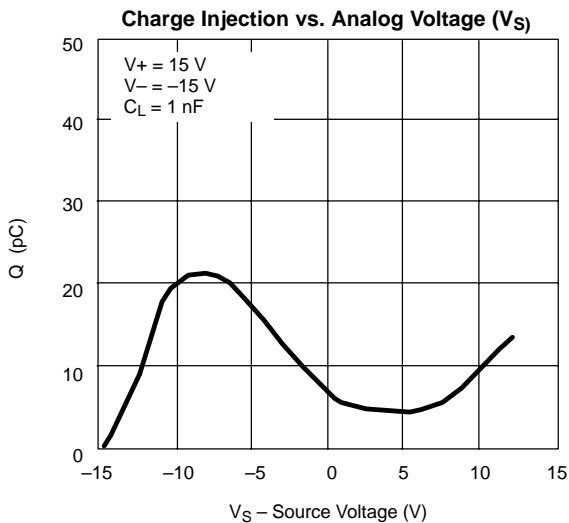
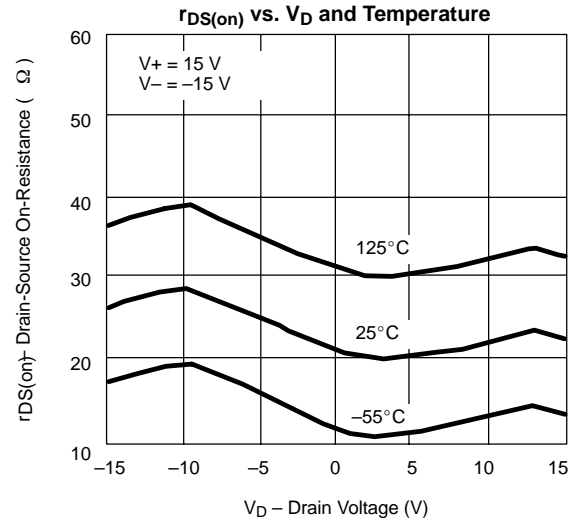
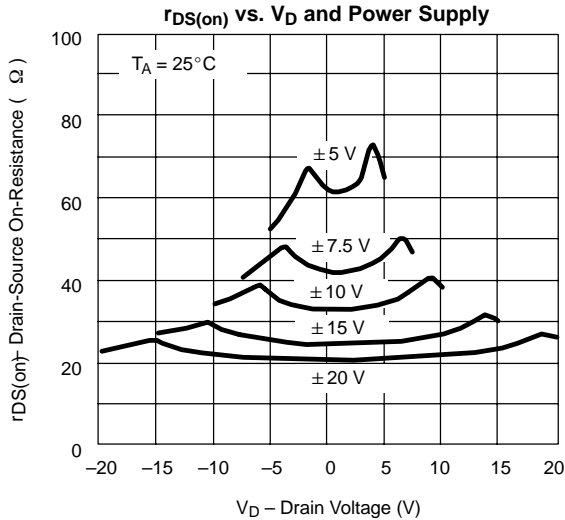



TYPICAL CHARACTERISTICS (25°C UNLESS NOTED)

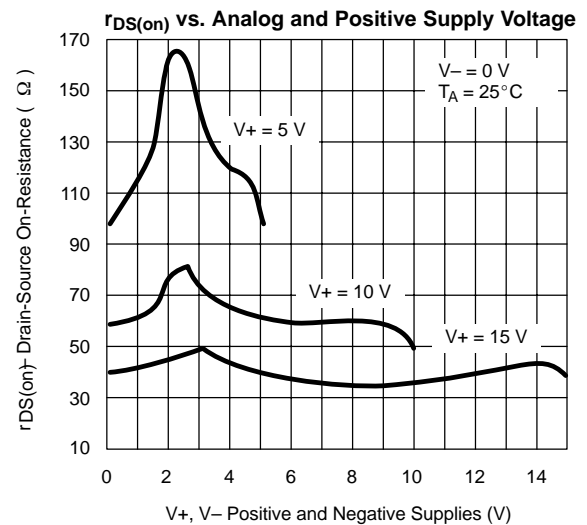
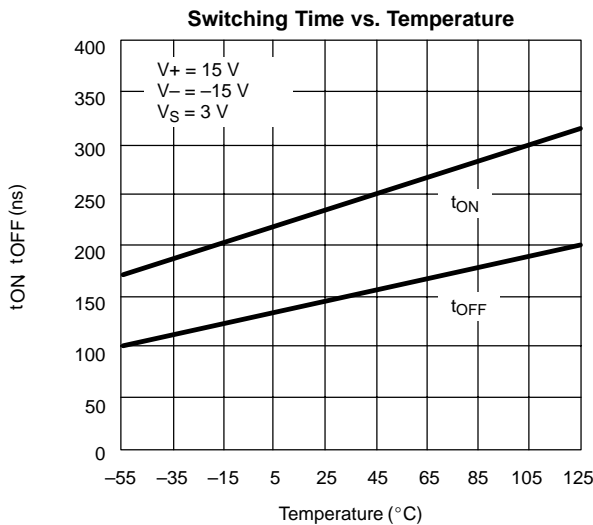
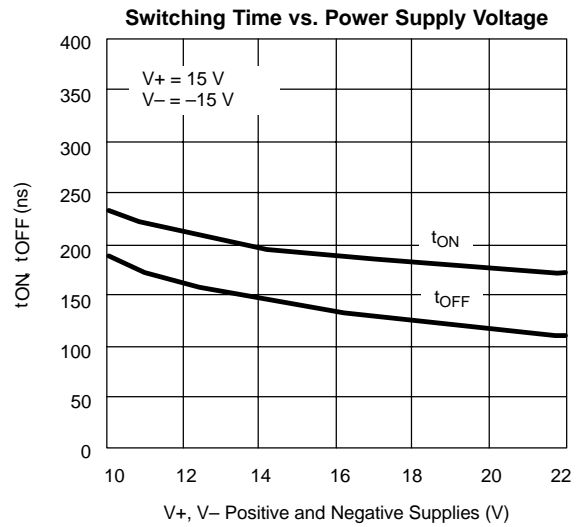
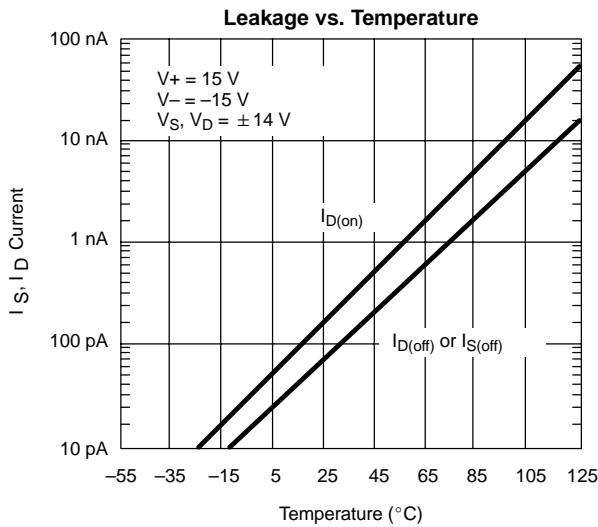
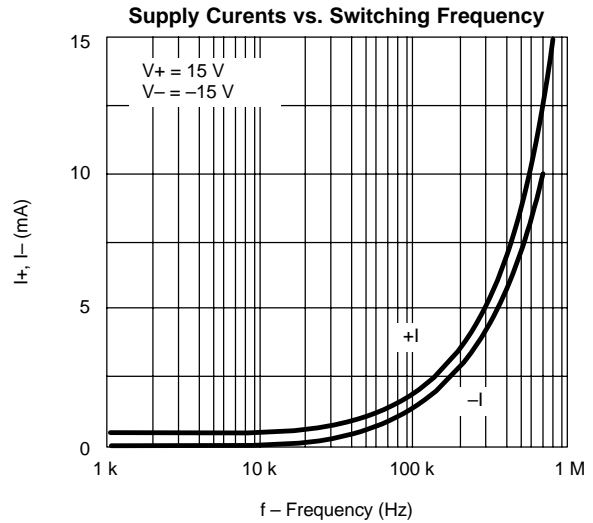
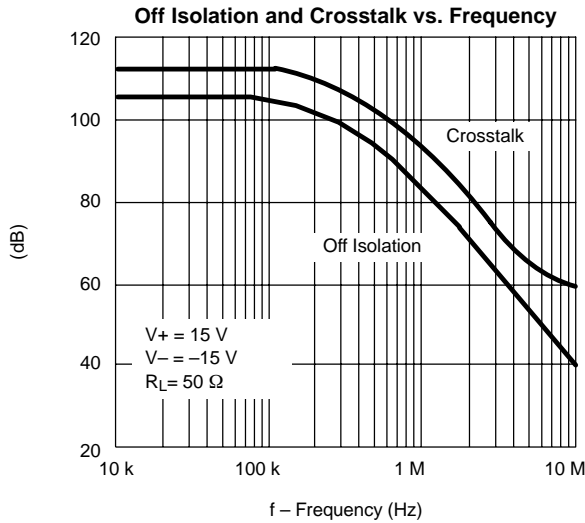

TEST CIRCUITS

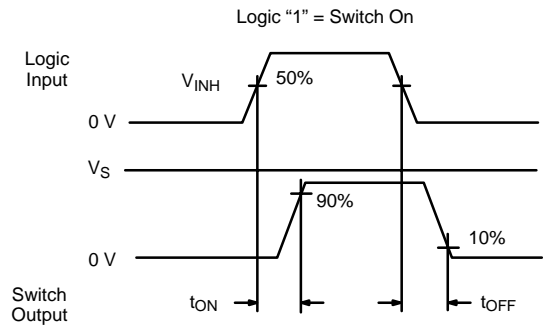
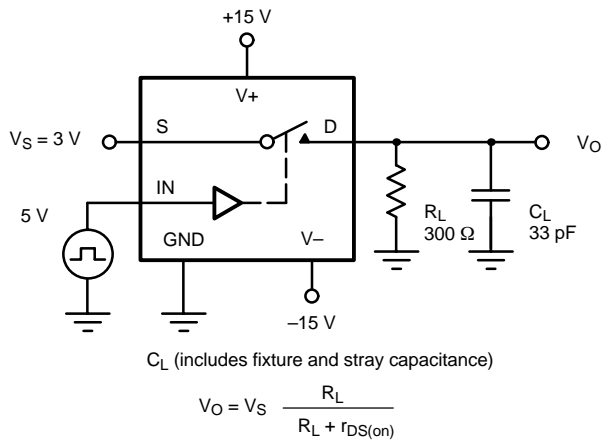

FIGURE 2. Switching Time

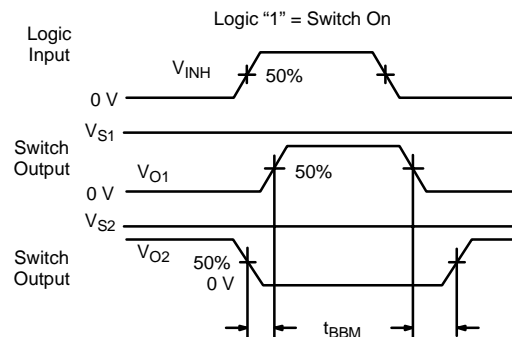
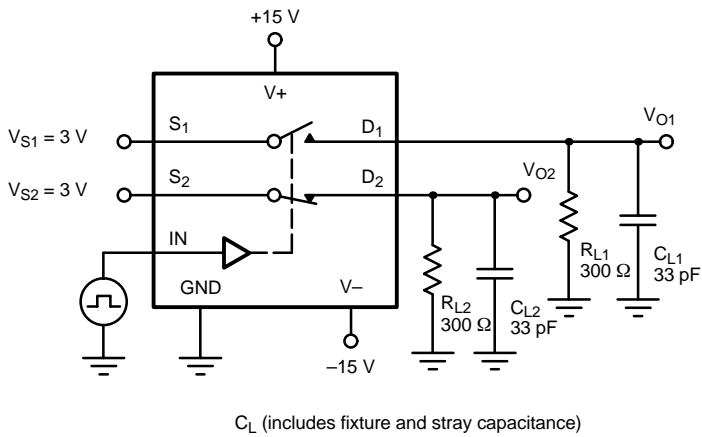

FIGURE 3. Break-Before-Make SPDT (DG387B, DG390B)

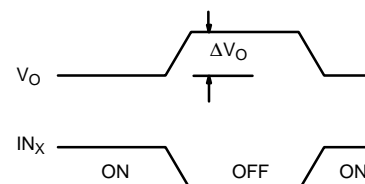
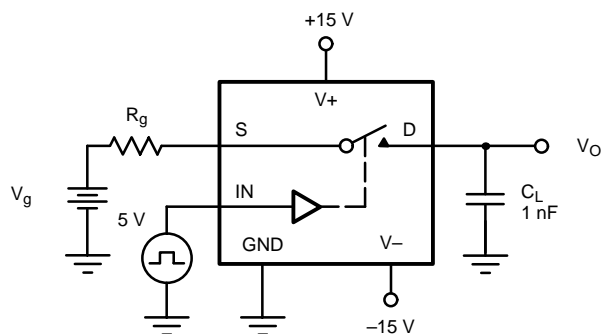

FIGURE 4. Charge Injection

APPLICATIONS

The DG381B series of analog switches will switch positive analog signals while using a single positive supply. This allows their use in applications where only one supply is available. The trade-offs or performance given up while using single supplies are: 1) increased $r_{DS(on)}$, 2) slower switching speed. Typical curves for aid in designing with single supplies are supplied (see Typical Characteristics). The analog voltage should not go above or below the supply voltages which in single operation are $V+$ and 0 V.

In the integrator of Figure 4, R_D controls the discharge rate of the capacitor so that the pulsed or continuous current ratings are not exceeded. During reset SW_1 is closed and SW_2 is open. Opening SW_2 with SW_1 also open will hold the integrator output at its present value.

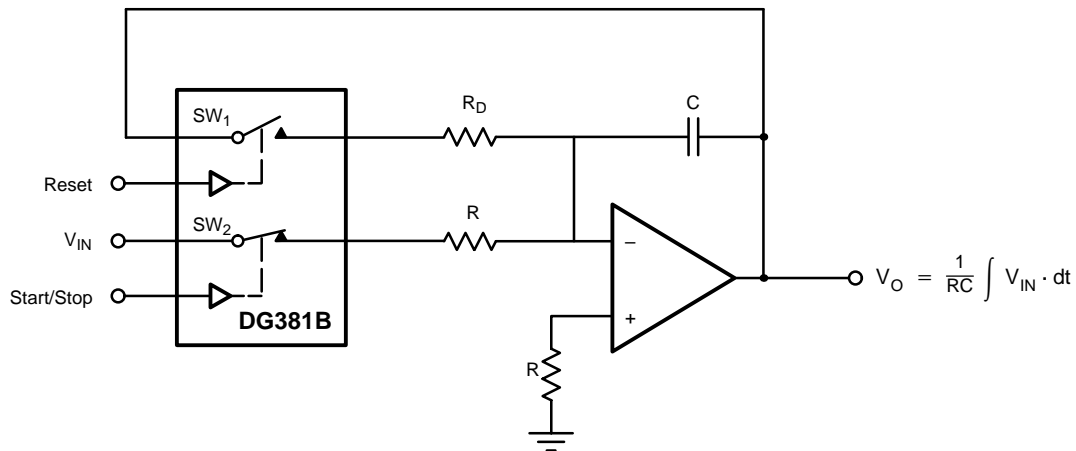

FIGURE 5. Integrator with Reset and Start/Stop



Notice

Specifications of the products displayed herein are subject to change without notice. Vishay Intertechnology, Inc., or anyone on its behalf, assumes no responsibility or liability for any errors or inaccuracies.

Information contained herein is intended to provide a product description only. No license, express or implied, by estoppel or otherwise, to any intellectual property rights is granted by this document. Except as provided in Vishay's terms and conditions of sale for such products, Vishay assumes no liability whatsoever, and disclaims any express or implied warranty, relating to sale and/or use of Vishay products including liability or warranties relating to fitness for a particular purpose, merchantability, or infringement of any patent, copyright, or other intellectual property right.

The products shown herein are not designed for use in medical, life-saving, or life-sustaining applications. Customers using or selling these products for use in such applications do so at their own risk and agree to fully indemnify Vishay for any damages resulting from such improper use or sale.