



Low Power, High Voltage SPST Analog Switches

DESCRIPTION

The DG467 and DG468 are dual supply single-pole/single-throw (SPST) switches. On resistance is 10 Ω maximum and flatness is 2 Ω max over the specified analog signal range. These analog switches were designed to provide high speed, low error switching of precision analog signals. The primary application areas are in the routing and switching in telecommunications and test equipment. Combining low power, low leakages, low on-resistance and small physical size, the DG467/468 are also ideally suited for portable and battery powered industrial and military equipment.

The DG467 has one normally closed switch, while the DG468 switch is normally open. They operate either from a single + 7 V to 36 V supply or from dual ± 4.5 V to ± 20 V supplies. They are offered in the very popular, small TSOP6 package.

FEATURES

- ± 15 V Analog Signal Range
- On-Resistance - $r_{DS(on)}$: 10 Ω max
- Fast Switching Action - T_{ON} : 100 ns
- V_L Logic Supply Not Required
- TTL CMOS Input Compatible
- Rail To Rail Signal Handling
- Dual Or Single Supply Operation



RoHS
COMPLIANT

BENEFITS

- Wide Dynamic Range
- Low Signal Errors and Distortion
- Break-Before-Make Switching Action
- Simple Interfacing
- Reduced Board Space
- Improved Reliability

APPLICATIONS

- Precision Test Equipment
- Precision Instrumentation
- Communications Systems
- PBX, PABX Systems
- Audio Equipment
- Redundant Systems
- PC Multimedia Boards
- Hard Disc Drives

FUNCTIONAL BLOCK DIAGRAM AND PIN CONFIGURATION

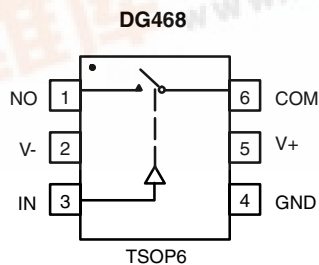
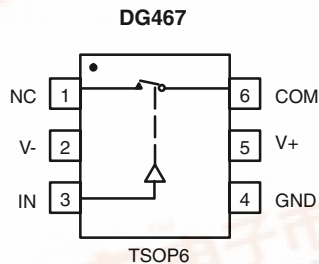

TRUTH TABLE

| Logic | DG467 | DG468 |
|-------|-------|-------|
| 0 | ON | OFF |
| 1 | OFF | ON |

Logic "0" ≤ 0.8 V

Logic "1" ≥ 2.4 V

Device Marking:

DG467DV = G7xxx

DG468DV = G8xxx



DG467/DG468

Vishay Siliconix



| ORDERING INFORMATION | | |
|----------------------|------------|---------------|
| Temp Range | Package | Part Number |
| DG467/DG468 | | |
| - 40 to 85 °C | 6-Pin TSOP | DG467DV-T1-E3 |
| | | DG468DV-T1-E3 |

| ABSOLUTE MAXIMUM RATINGS $T_A = 25\text{ }^\circ\text{C}$, unless otherwise noted | | | |
|------------------------------------------------------------------------------------|-------------------------|--------------------------------------------------------------|------|
| Parameter Referenced To V- | Symbol | Limit | Unit |
| V+ | | 44 | V |
| GND | | 25 | |
| Digital Inputs ^a , $V_{NO/NC}$, V_{COM} | | (V-) - 2 V to (V+) + 2 V or 30 mA, whichever occurs first | |
| Current, (Any Terminal) Continuous | | 30 | mA |
| Current (NO or NC or COM) Pulsed at 1 ms, 10 % duty cycle | | 100 | |
| Storage Temperature | | - 65 to 150 | °C |
| Power Dissipation (Package) ^b | 6-Pin TSOP ^c | 570 | mW |

Notes:

- a. Signals on NO, NC, COM, or IN exceeding V+ or V- will be clamped by internal diodes. Limit forward diode current to maximum current ratings.
- b. All leads welded or soldered to PC Board.
- c. Derate 7 mW/°C above 70 °C.



| SPECIFICATIONS^a ($V_{\pm} = \pm 15\text{ V}$) | | | | | | | |
|----------------------------------------------------------------------------|----------------------|-----------------------------------------------------------------------------------------------------------------------------------------------|-------------------|---------------------------|------------------|------------------|---------------|
| Parameter | Symbol | Test Conditions Unless Otherwise Specified $V_{+} = 15\text{ V}$, $V_{-} = -15\text{ V}$ $V_{IN} = 2.4\text{ V}$, 0.8 V^f | Temp ^b | D Suffix - 40 to 85 °C | | | Unit |
| | | | | Min ^d | Typ ^c | Max ^d | |
| Analog Switch | | | | | | | |
| Analog Signal Range ^e | V_{ANALOG} | | Full | - 15 | | 15 | V |
| Drain-Source On-Resistance | r_{ON} | $I_{NO/NC} = 10\text{ mA}$, $V_{COM} = 10\text{ V}$ $V_{+} = 13.5\text{ V}$, $V_{-} = -13.5\text{ V}$ | Room Full | | 7 | 9 10 | Ω |
| On-Resistance Flatness | r_{ON} Flatness | $I_{NO/NC} = 10\text{ mA}$, $V_{COM} = \pm 5\text{ V}$, 0 V $V_{+} = 13.5\text{ V}$, $V_{-} = -13.5\text{ V}$ | Room Full | | 0.7 | 1 2 | |
| Switch Off Leakage Current | $I_{NO/NC(off)}$ | $V_{+} = 16.5\text{ V}$, $V_{-} = -16.5\text{ V}$ $V_{COM} = \pm 15.5\text{ V}$ $V_{NO/NC} = -/+ 15.5\text{ V}$ | Room Full | - 1 - 10 | - 0.1 | 1 10 | nA |
| | $I_{COM(off)}$ | | Room Full | - 1 - 10 | - 0.1 | 1 10 | |
| Channel On Leakage Current | $I_{COM(on)}$ | $V_{+} = 16.5\text{ V}$, $V_{-} = -16.5\text{ V}$ $V_{COM} = V_{NO/NC} = \pm 15.5\text{ V}$ | Room Full | - 1 - 10 | - 0.1 | 1 10 | |
| Digital Control | | | | | | | |
| Input, High Voltage | I_{INH} | | Full | 2.4 | | | V |
| Input, Low Voltage | I_{INL} | | Full | | | 0.8 | |
| Input Capacitance ^e | C_{IN} | | Room | | 5 | | pF |
| Input Current | I_{IN} | $V_{IN} = 0\text{ or }5\text{ V}$ | | - 1 | | 1 | μA |
| Dynamic Characteristics | | | | | | | |
| Turn-On Time | t_{ON} | $R_L = 300\ \Omega$, $C_L = 35\text{ pF}$ $V_{NO/NC} = \pm 10\text{ V}$ | Room Full | | 100 | 140 160 | ns |
| Turn-Off Time | t_{OFF} | | Room Full | | 50 | 80 100 | |
| Charge Injection ^e | Q | $C_L = 1\text{ nF}$, $V_{gen} = 0\text{ V}$, $R_{gen} = 0\ \Omega$ | Room | | 21 | | pC |
| Off-Isolation ^e | OIRR | $C_L = 5\text{ pF}$, $R_L = 50\ \Omega$, $f = 1\text{ MHz}$ | Room | | - 61 | | dB |
| Source Off Capacitance ^e | $C_{S(off)}$ | $f = 1\text{ MHz}$ | Room | | 30 | | pF |
| Drain Off Capacitance ^e | $C_{D(off)}$ | | Room | | 15 | | |
| Channel On Capacitance ^e | $C_{D(on)}$ | | Room | | 76 | | |
| Power Supplies | | | | | | | |
| Positive Supply Current | I+ | $V_{+} = 16.5\text{ V}$, $V_{-} = -16.5\text{ V}$ $V_{IN} = 0\text{ or }5\text{ V}$ | Room Full | | 5 | 15 20 | μA |
| Negative Supply Current | I- | | Room Full | - 1 - 10 | - 0.02 | | |



| SPECIFICATIONS ^a (V ₊ = 12 V) | | | | | | | |
|-----------------------------------------------------|-----------------------------|---------------------------------------------------------------------------------------------------------------------------------------------|-------------------|---------------------------|------------------|------------------|------|
| Parameter | Symbol | Test Conditions Unless Otherwise Specified V ₊ = 12 V, V ₋ = 0 V V _{IN} = 2.4 V, 0.8 V ^f | Temp ^b | D Suffix - 40 to 85 °C | | | Unit |
| | | | | Min ^d | Typ ^c | Max ^d | |
| Analog Switch | | | | | | | |
| Analog Signal Range ^e | V _{ANALOG} | | Full | 0 | | 12 | V |
| Drain-Source On-Resistance | r _{ON} | I _{NO/NC} = -10 mA, V _{COM} = 8 V V ₊ = 10.8 V | Room Full | | 12 | 16 20 | Ω |
| On-Resistance Flatness | r _{ON} Flatness | I _{NO/NC} = 10 mA, V _{COM} = 2, 6, 8 V V ₊ = 10.8 V | Room Full | | 1.5 | 3 4 | Ω |
| Dynamic Characteristics | | | | | | | |
| Turn-On Time | t _{ON} | V _{NO, NC} = ± 10 V, R _L = 300 Ω, C _L = 35 pF | Room Full | | 130 | 160 200 | nS |
| Turn-Off Time | t _{OFF} | | Room Full | | 50 | 80 100 | |
| Charge Injection ^e | Q | C _L = 1 nF, V _{gen} = 0 V, R _{gen} = 0 Ω | Room | | 8 | | pC |
| Power Supplies | | | | | | | |
| Positive Supply Current | I ₊ | V ₊ = 13.2 V, V _{IN} = 0 V, 5 V | Room Full | | 3 | 7 10 | μA |

Notes:

- a. Refer to PROCESS OPTION FLOWCHART.
- b. Room = 25 °C, Full = as determined by the operating temperature suffix.
- c. Typical values are for DESIGN AID ONLY, not guaranteed nor subject to production testing.
- d. The algebraic convention whereby the most negative value is a minimum and the most positive a maximum, is used in this data sheet.
- e. Guaranteed by design, not subject to production test.
- f. V_{IN} = input voltage to perform proper function.

Stresses beyond those listed under "Absolute Maximum Ratings" may cause permanent damage to the device. These are stress ratings only, and functional operation of the device at these or any other conditions beyond those indicated in the operational sections of the specifications is not implied. Exposure to absolute maximum rating conditions for extended periods may affect device reliability.



TYPICAL CHARACTERISTICS $T_A = 25\text{ }^\circ\text{C}$, unless otherwise noted

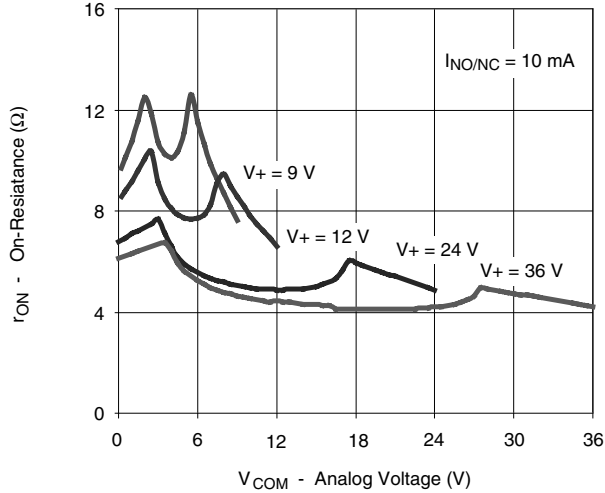

r_{ON} vs. V_{COM} and Single Supply Voltage

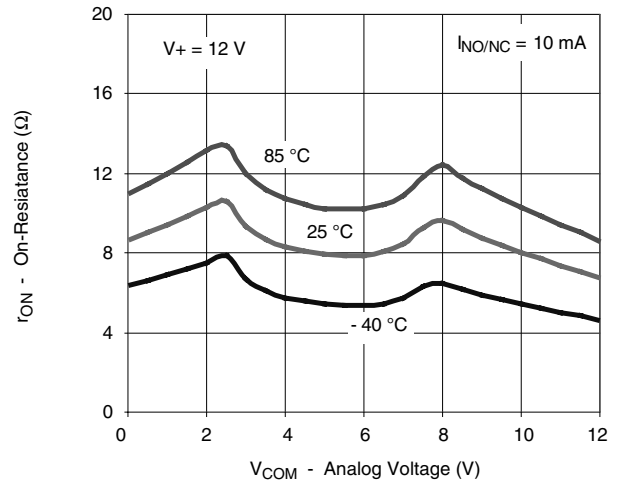

r_{ON} vs. Analog Voltage and Temperature

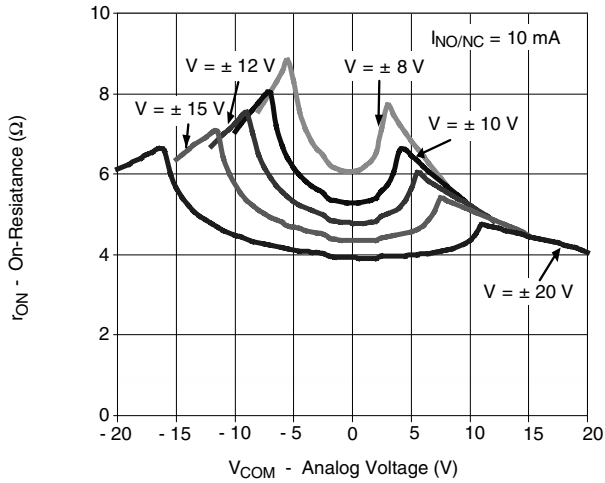

r_{ON} vs. V_{COM} and Dual Supply Voltage

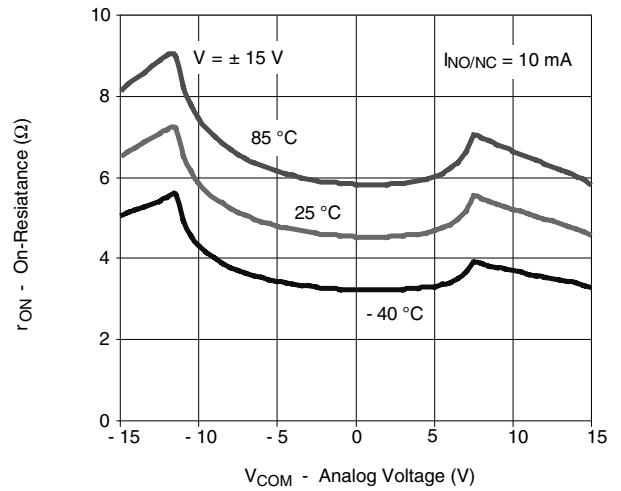

r_{ON} vs. Analog Voltage and Temperature

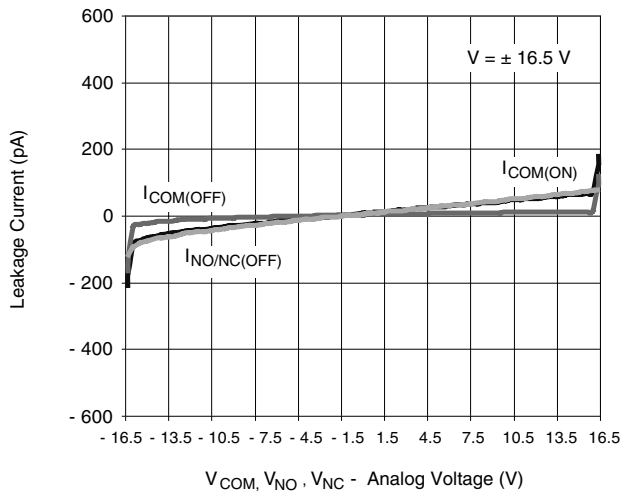

Leakage vs. Analog Voltage

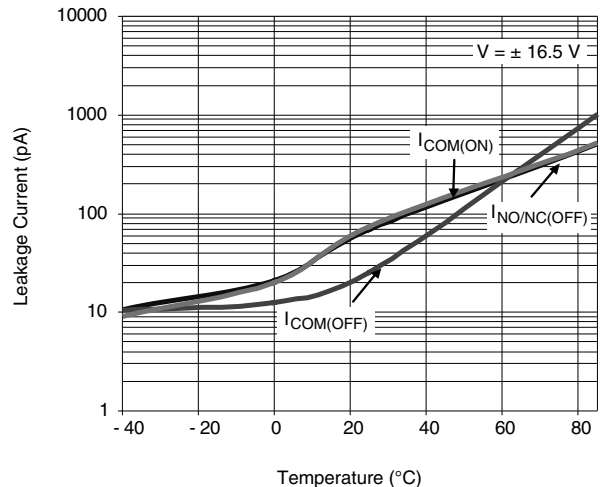

Leakage Current vs. Temperature

DG467/DG468

Vishay Siliconix



TYPICAL CHARACTERISTICS $T_A = 25\text{ }^\circ\text{C}$, unless otherwise noted

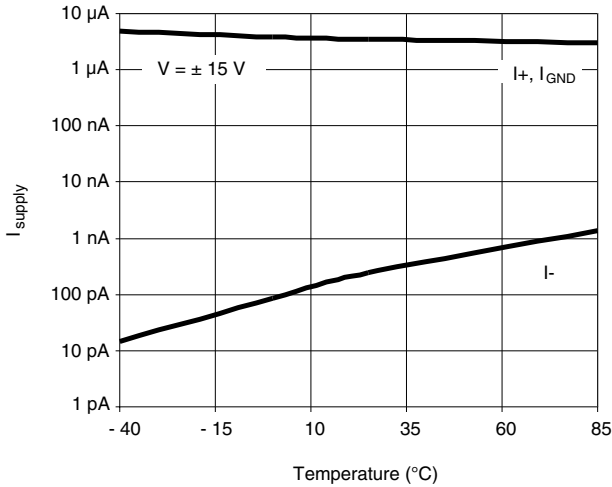

Supply Current vs. Temperature

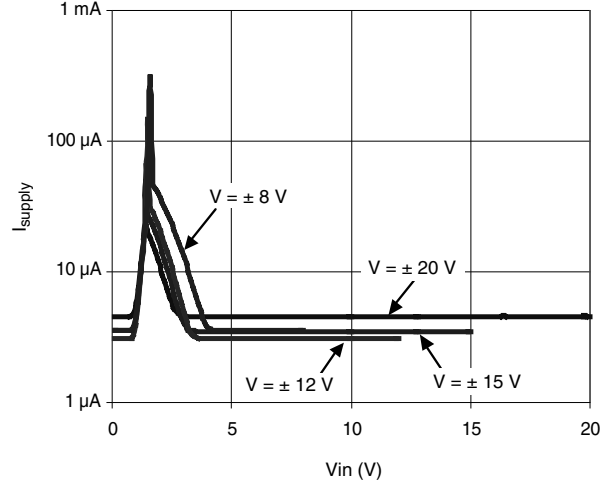

Supply Current vs. V_{IN}

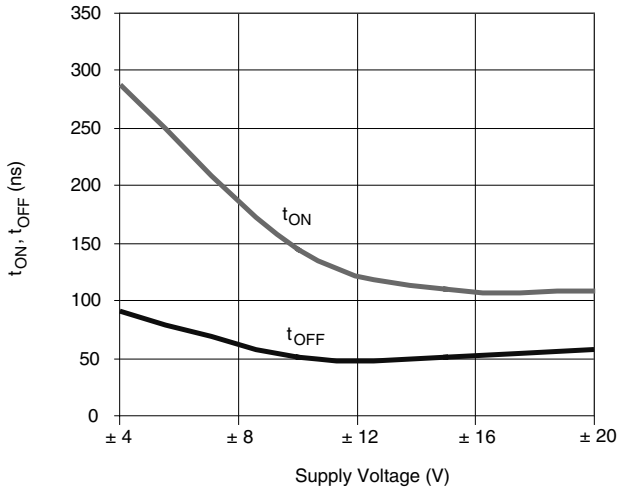

Switching Time vs. Supply Voltages

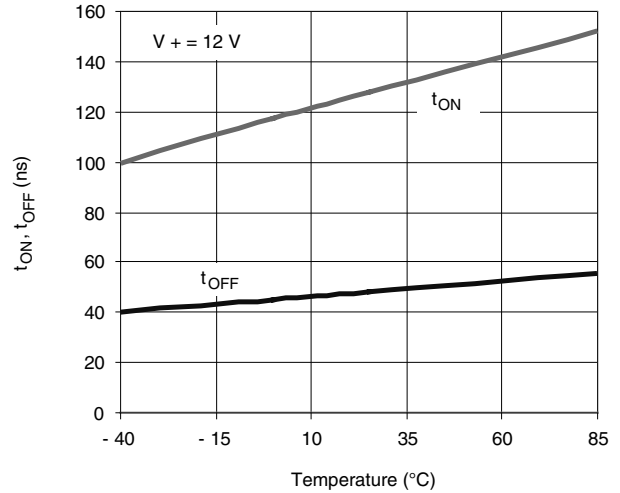

Switching Time vs. Temperature

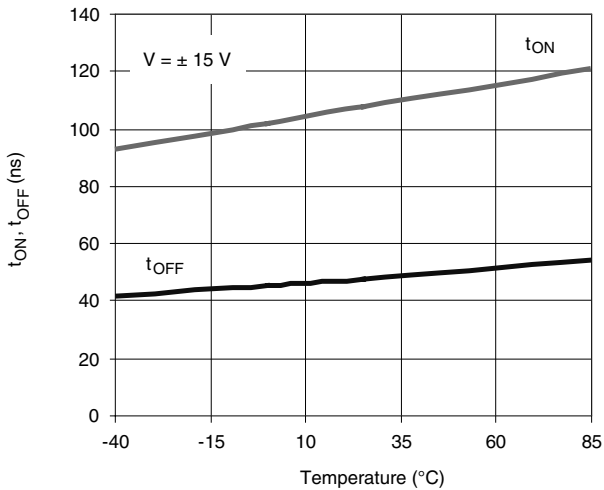

Switching Time vs. Temperature

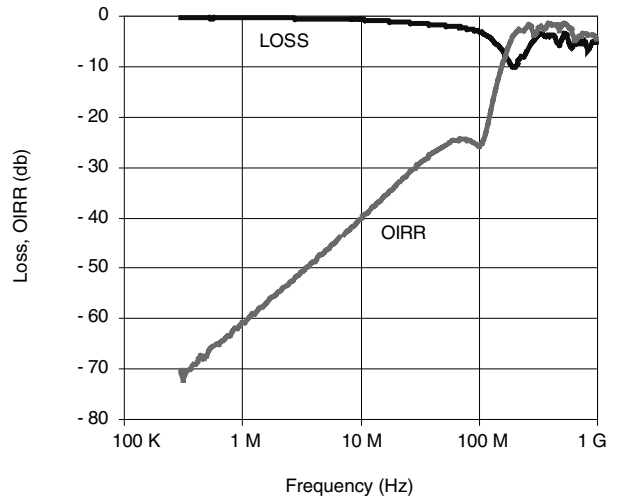

Off Isolation and Insertion Loss vs. Frequency

TYPICAL CHARACTERISTICS $T_A = 25\text{ }^\circ\text{C}$, unless otherwise noted

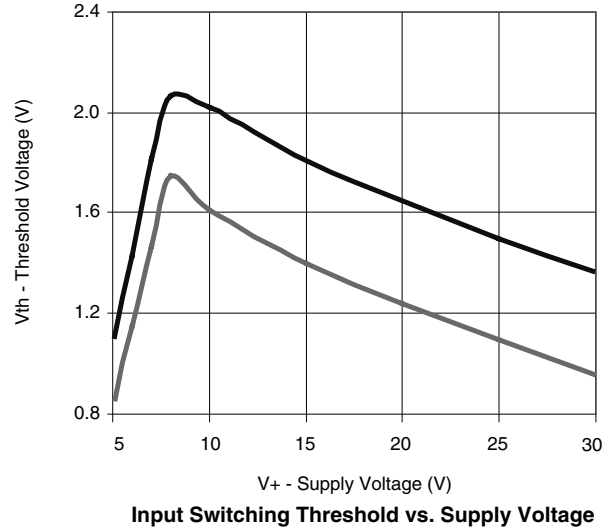
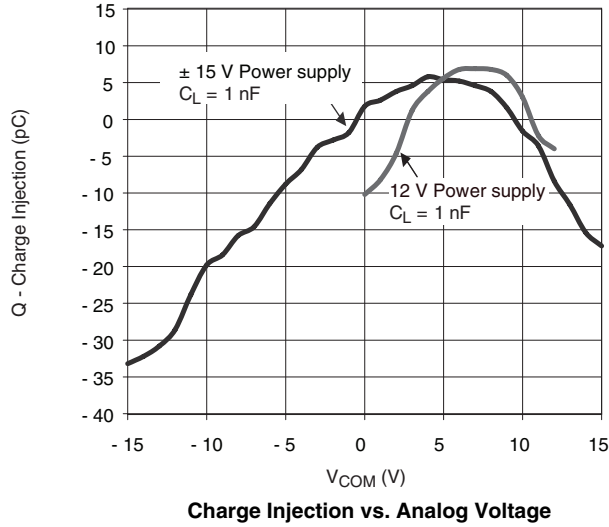

TEST CIRCUITS

V_O is the steady state output with the switch on.

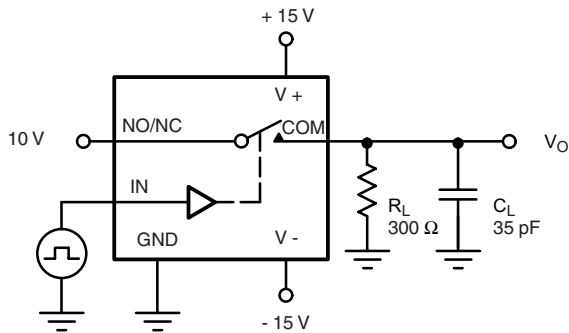

C_L (includes fixture and stray capacitance)

$$V_O = V_S \frac{R_L}{R_L + r_{ON}}$$

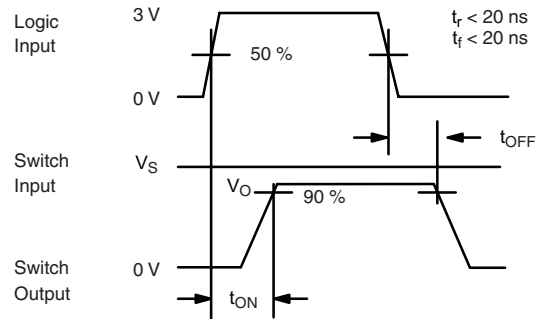

Note: Logic input waveform is inverted for switches that have the opposite logic sense.

Figure 1. Switching Time

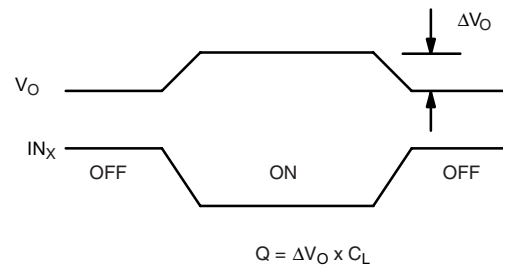
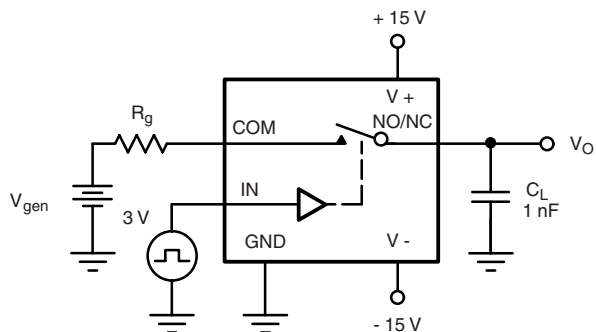

Figure 2. Charge Injection

TEST CIRCUITS

V_O is the steady state output with the switch on.

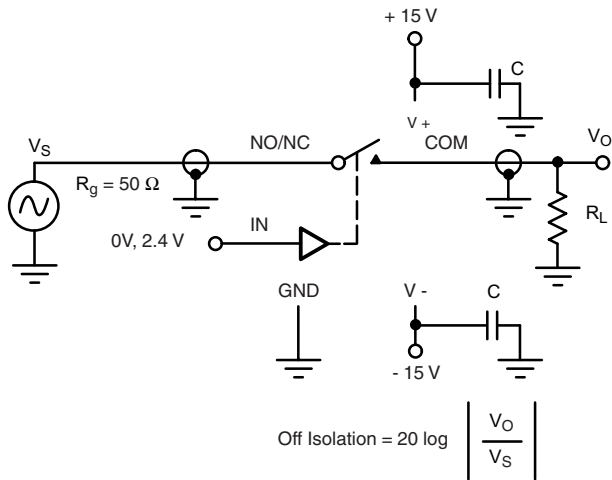

Figure 3. Off Isolation

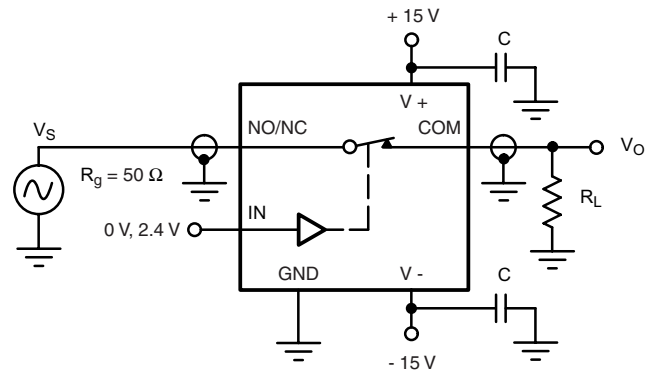

Figure 4. Insertion Loss

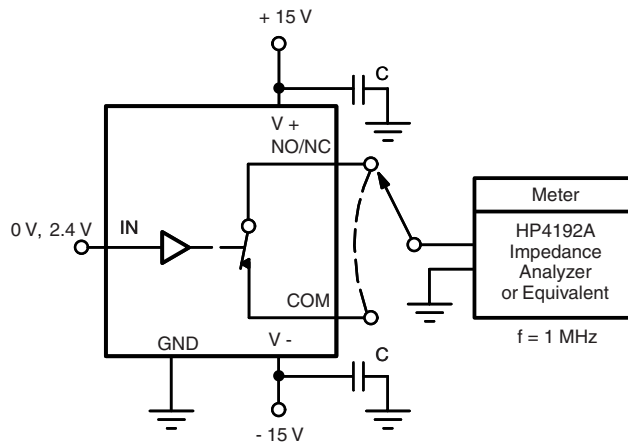

Figure 5. Source/Drain Capacitances



Disclaimer

All product specifications and data are subject to change without notice.

Vishay Intertechnology, Inc., its affiliates, agents, and employees, and all persons acting on its or their behalf (collectively, "Vishay"), disclaim any and all liability for any errors, inaccuracies or incompleteness contained herein or in any other disclosure relating to any product.

Vishay disclaims any and all liability arising out of the use or application of any product described herein or of any information provided herein to the maximum extent permitted by law. The product specifications do not expand or otherwise modify Vishay's terms and conditions of purchase, including but not limited to the warranty expressed therein, which apply to these products.

No license, express or implied, by estoppel or otherwise, to any intellectual property rights is granted by this document or by any conduct of Vishay.

The products shown herein are not designed for use in medical, life-saving, or life-sustaining applications unless otherwise expressly indicated. Customers using or selling Vishay products not expressly indicated for use in such applications do so entirely at their own risk and agree to fully indemnify Vishay for any damages arising or resulting from such use or sale. Please contact authorized Vishay personnel to obtain written terms and conditions regarding products designed for such applications.

Product names and markings noted herein may be trademarks of their respective owners.