

Preliminary



DLBM-CF120

DLBM-CF120 Bluetooth™ Module Class 2

A Class 2 Bluetooth module suitable for various applications.

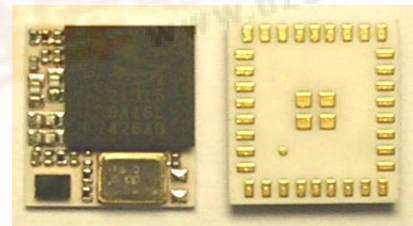

1. FEATURES:

- **Built-in 4M Flash memory.**
- **Suitable for Cellular, PDA, PC, GPS... applications.**
- **Reducing the size and thickness greatly using high-density packaging technology.**
- **High sensitivity to achieve better performance.**
- **Compliant to various interfaces: UART, USB, PCM, PIO...**
- **Wide operating temperature range: -30~+80 °C.**

2. Device diagram

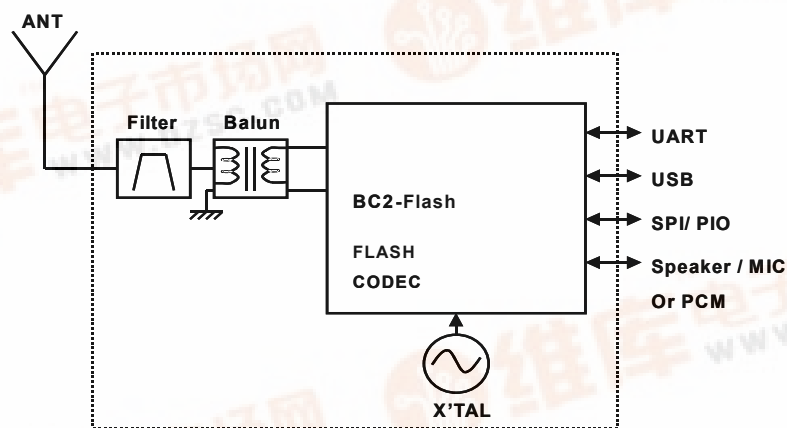

Figure 1. DLBM-CF120 Block Diagram





3. General Specification

Bluetooth™ Specification	Version 1.1
Frequency	2402~2480MHz
Modulation	FHSS/GFSK
Transmission rate	721kbps
Receive sensitivity	-83dBm
Maximum output power	+4dBm(Class 2)
Operating Voltage	1.8V or 2.2~3.6V
Operating temperature	-30~+80°C
Antenna Impedance	50 ohm
Flash memory	4M bit
Package size	9.1*7.9*1.6mm
Operating range	Up to 10 meters

4. Rating

	Min	Max	Unit
Storage Temperature	-40	+85	°C
VDD_1.8V	-0.4	+1.9	V
VDD_IO	-0.4	+3.6	V
VREG_IN	-0.4	+3.6	V



5.Interface

Interface	Description
Antenna	External Antenna 50 ohm
UART Interface	TX,RX,RTS,CTS(9600bps~1.5Mbps)
SPI Interface	Synchronous Serial Interface for firmware download
PIO Interface	8 terminals

6.Power Supply Diagram

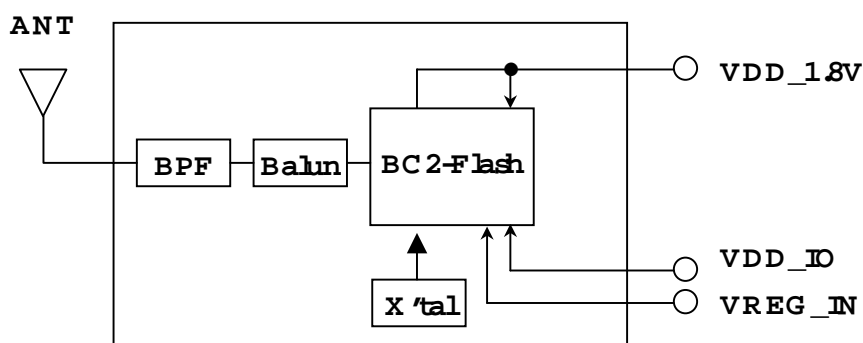

Figure 2. Power Supply Diagram

Terminal	3.0V Power Supply	1.8V Power Supply
VDD_1.8V	NC	1.7 to 1.9V
VDD_IO	1.7 to 3.6V	1.7 to 1.9V
VREG_IN	2.2 to 3.6V	NC



7. RF Characteristics

Operating Condition: +25°C, VDD=1.8V

RF Characteristics	Min.	Typ.	Max.	Unit
1. Frequency Range	2400 ~ 2483.5			MHz
2. Output Power	-6	1.5	4	dBm
3. Sensitivity at 0.1% BER				
1) 2402MHz	-70	-82		dBm
2) 2441MHz	-70	-82		dBm
3) 2480MHz	-70	-82		dBm
4. Maximum Input Level (BER≤0.1%)	-20	0		dBm
5. Adjacent channel selectivity				
1) C/I F=F ₀ + 1MHz		-4	0	dB
2) C/I F=F ₀ - 1MHz		-4	0	dB
3) C/I F=F ₀ + 2MHz		-35	-30	dB
4) C/I F=F ₀ - 2MHz		-21	-20	dB
5) C/I F≥F ₀ + 3MHz		-45		dB
6) C/I F≤F ₀ - 5MHz		-45		dB
7) C/I F=F _{Image}		-18	-9	dB
6. Adjacent channel transmit power				
1) F=F ₀ ± 2MHz		-35	-20	dBc
2) F=F ₀ ± 3MHz		-55	-40	dBc
7. Modulation Characteristics				
1) Modulation Δf _{1avg}	140	165	175	kHz
2) Modulation Δf _{2max}	115	155		kHz
8. Initial Carrier Frequency Tolerance				
1) 2402MHz	-75	16	75	kHz
2) 2441MHz	-75	13	75	kHz
3) 2480MHz	-75	14	75	kHz

Preliminary



DLBM-CF120

9. Carrier Frequency Drift				
1) 1slot	-20	9	20	kHz
2) 5slot	-25	10	25	kHz
4) Drift rate	-20	6.5	20	KHz/50us
10. 20dB Bandwidth for modulated carrier				
1) 2402MHz		879	1000	KHz
2) 2441MHz		816	1000	KHz
3) 2480MHz		819	1000	KHz
11.C/I co - channel		9	11	dB

8 Application Circuit

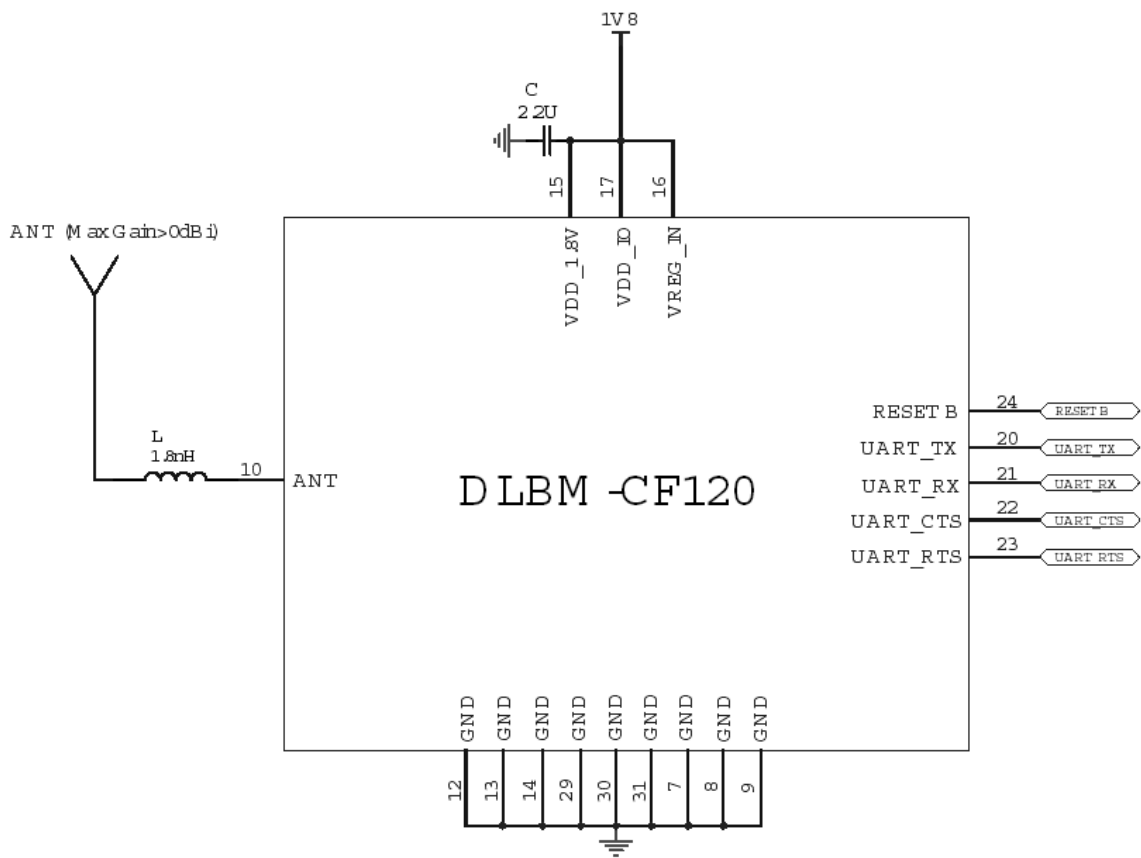

Figure 3. Application circuit by 1.8V supply

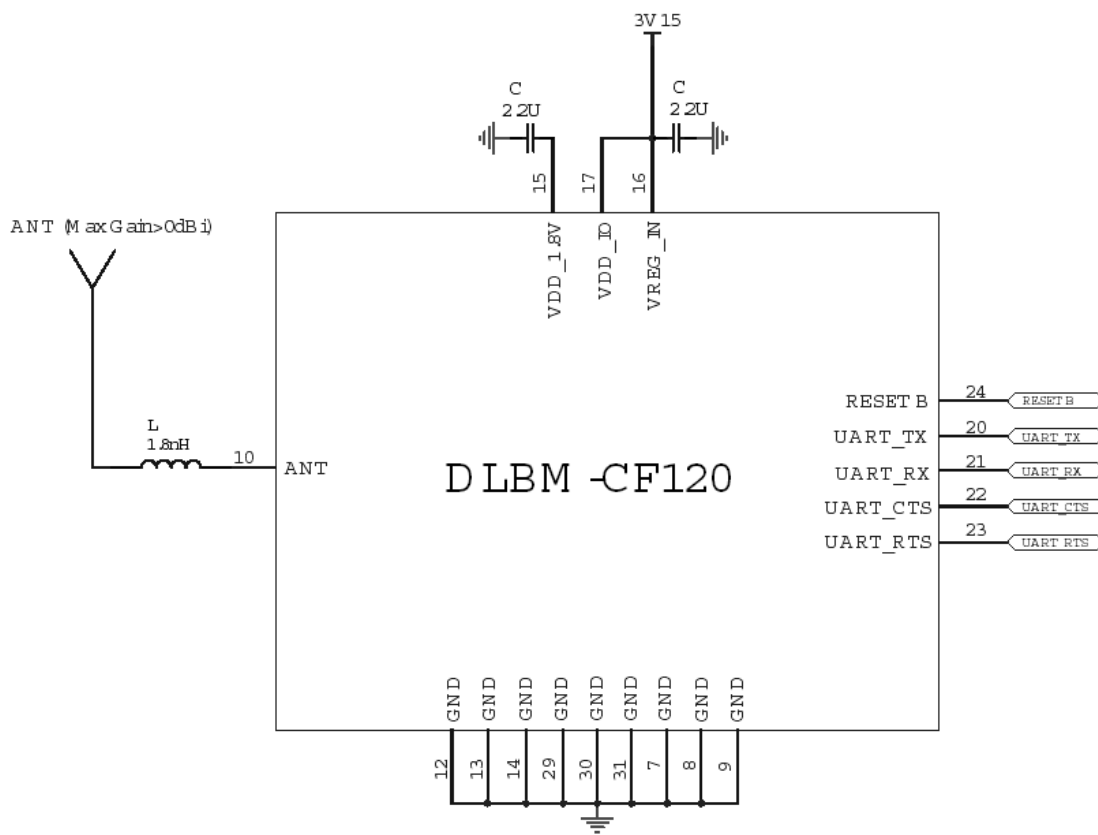

Figure 4. Application circuit by 3.15V supply



9. RECOMMENDED REFLOW PROFILE

The temperature rise to 150°C for preliminary heating shall be made for 30 seconds or longer. The preliminary heating shall be done at the temperature of 160°C±10°C for 60 ~ 90 seconds. The heating shall be at the temperature of 200°C or higher for 20 ~ 40 seconds and the peak temperature shall be 230°C±5°C.

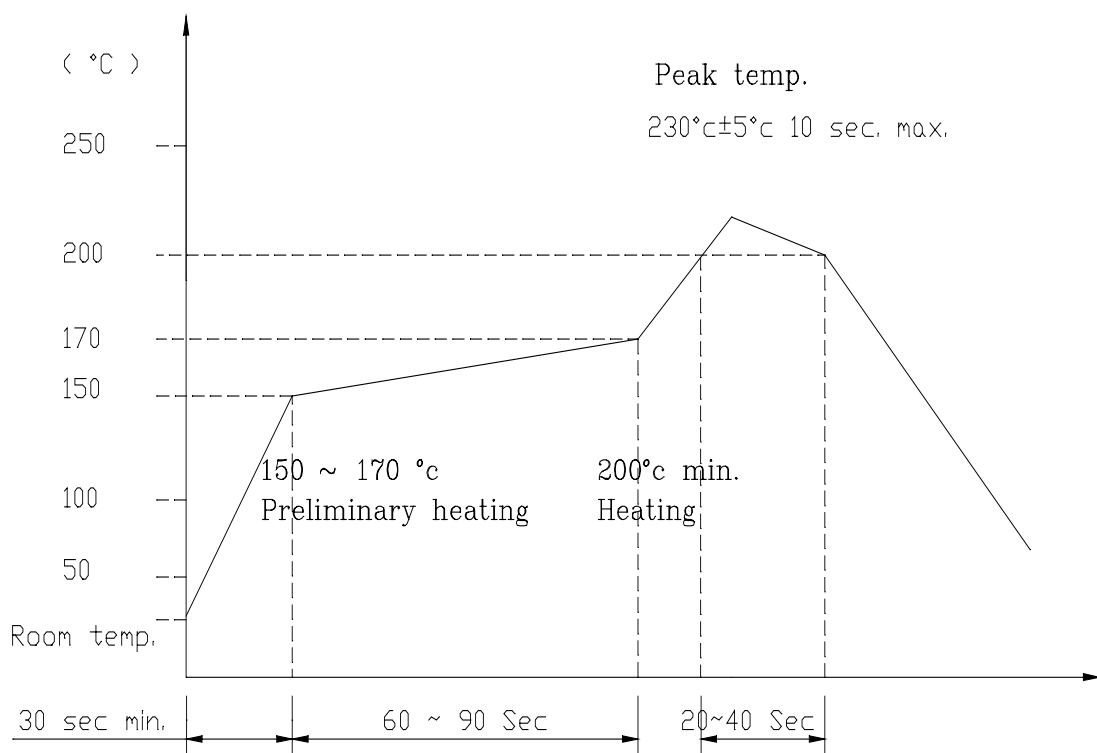

Figure 5. REFLOW PROFILE



10.Pin description

Pin No.	Name		Description
	DLBM-CF120	DLBM-CF121	
1	PIO_11		Programmable I/O terminal
2	PIO_9		Programmable I/O terminal
3	*SP+	PCM_OUT	/Speaker output positive (With Audio Profile) /Synchronous data output
4	*SP-	PCM_SYNC	/Speaker output negative (With Audio Profile) /Synchronous data sync
5	*MIC+	PCM_CLK	/Microphone input positive (With Audio Profile) /Synchronous data clock
6	*MIC-	PCM_IN	/Microphone input negative (With Audio Profile) /Synchronous data input
7	Gnd		
8	Gnd		
9	Gnd		
10	ANT		RF input/output
11	AIO_0		Programmable input/output
12	Gnd		
13	Gnd		
14	Gnd		
15	Vdd_1.8V		Refer to Power supply diagram

Preliminary



DLBM-CF120

16	VREG_IN	Refer to Power supply diagram
17	VDD_IO	Refer to Power supply diagram
18	USB_DN	USB data minus
19	USB_DP	USB data plus with selectable internal 1.5kohm pull-up resistor
20	UART_TX	UART data output active high
21	UART_RX	UART data input active high
22	UART_CTS	UART clear to send active low
23	UART_RTS	UART request to send active low
24	Reset_B	Reset if low
25	PIO_4	Programmable input/output line
26	PIO_5	Programmable input/output line
27	PIO_10	Programmable input/output line
28	PIO_3	Programmable input/output line
29	Gnd	
30	Gnd	
31	Gnd	
32	PIO_2	Programmable input/output line
33	PIO_1	Programmable input/output line
34	PIO_0	Programmable input/output line



DLBM-CF120

11. Dimensions (mm)

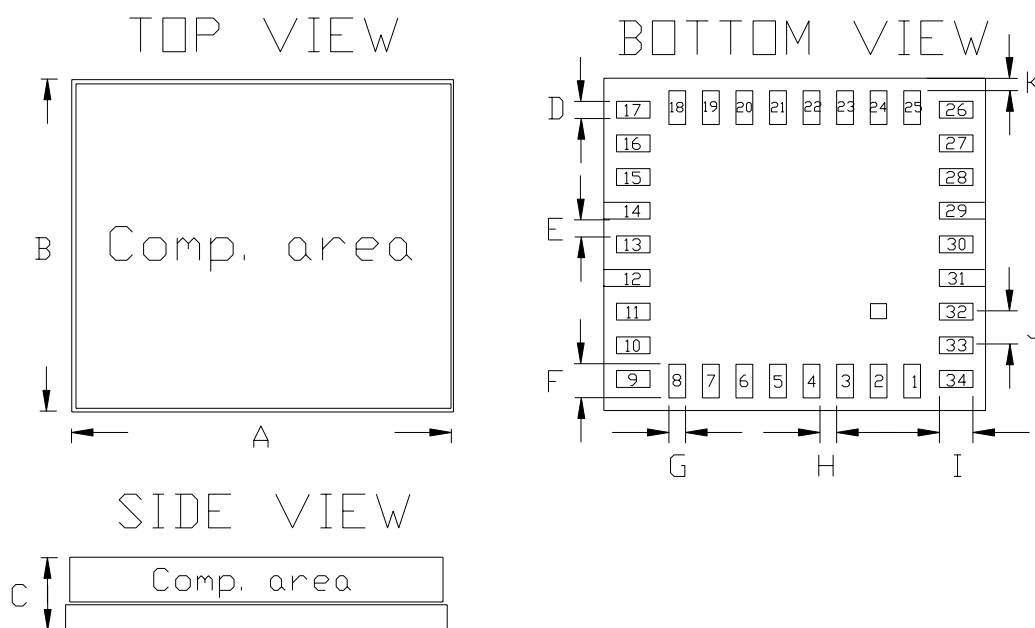

Unit:mm

A	9.1 ± 0.2	E	0.4	I	0.8
B	7.9 ± 0.2	F	0.8	J	0.8
C	1.6 ± 0.2	G	0.4	K	0.3
D	0.4	H	0.4		

Figure 6. Output pin dimensions

12. Layout Guide

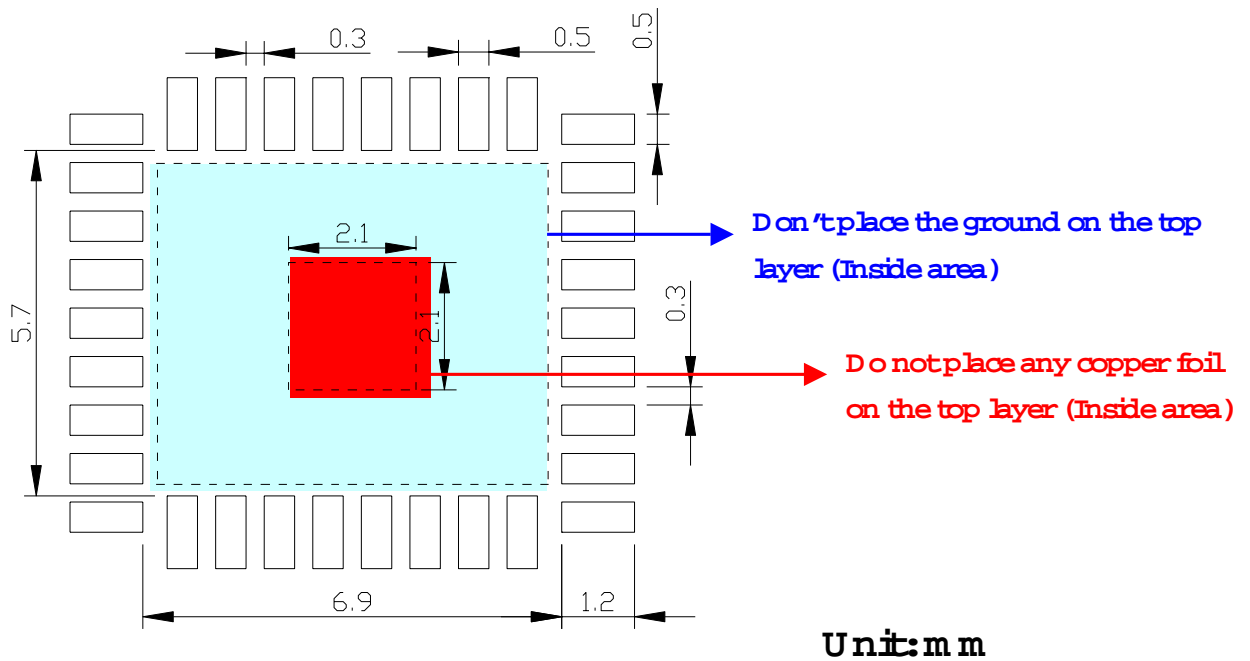

Figure 7. Land Pattern

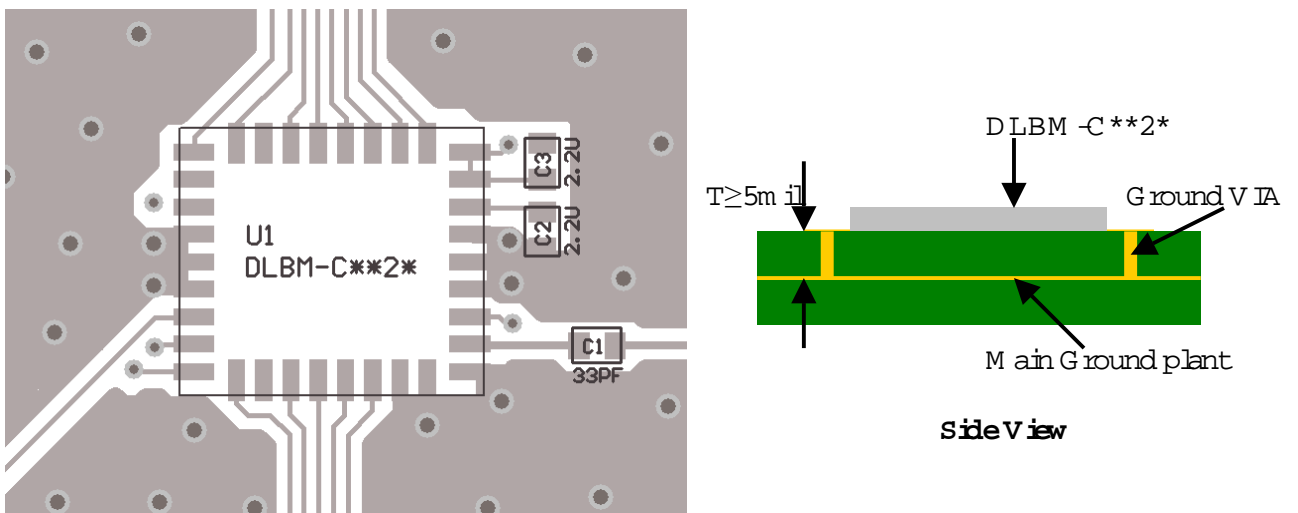
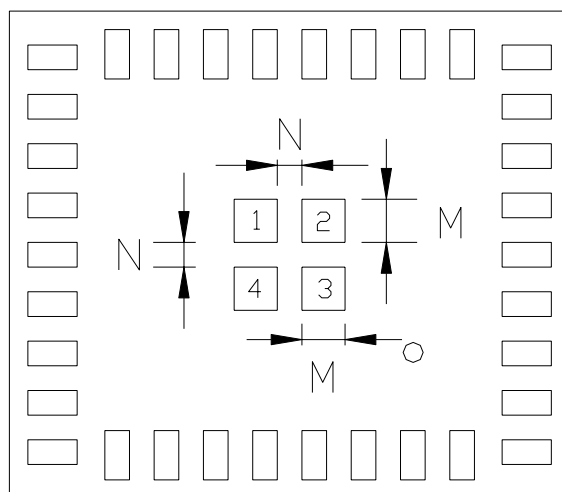

Figure 8. Layout Example



13. SPI Interface

BOTTOM VIEW



Unit:mm

M	0.7	1	SPI_CLK
N	0.4	2	SPI_CSB
		3	SPI_MOSI
		4	SPI_MISO

Contact information:

Website: <http://www.deltaww.com>

Email: Jonathan.Chen@delta.com.tw

Tel No.: 886-3-3591968#2925