

DATA SHEET

DN511

SUBMINIATURE PROPORTIONALLY CONTROLLED HEATER

GENERAL DESCRIPTION

The DN511 is a subminiature proportionally controlled heater, whose temperature can be programmed with a single external resistor. A unique design allows this device to operate over a large voltage range from 15volts to +60 Volts D.C. without drawing excessive current at turn-on. Temperature of the DN511 can be set at the factory upon request. The DN511 is in a ceramic package and can supply up to 3.5 watts of power from an unregulated power supply.

FEATURES

- BERYLLIA BASE FOR GOOD THERMAL CONDUCTION
- REGULATION TEMPERATURE FROM 5°C ABOVE AMBIENT TO 100°C
- 15 TO 70 VOLT OPERATION
- ELECTRICALLY ISOLATED FROM THE CASE

MAXIMUM RATINGS

Rating	Symbol	Value	Unit
Supply Voltage	VDD	70	VDC
Power Dissipation	PD	4	Watts
Operating Temperature	TMAX	120	°C
Storage Temperature	TMIN	-65 to +150	°C

OPERATING CHARACTERISTICS

Characteristic	Symbol	Min	Max	Unit
Supply Voltage (Pin 1 to Pin 2)	VDD	+15	+60	VDC
Supply Current at Turn on vs. Power Supply Voltage	ION	See Figure 2		mADC
Supply Current at Turn-on VDD = +30 Volts	ION	90	110	mADC
Temperature Variation over Operating Voltage	ΔT_v		2	°C
Temperature Variation with Load	ΔT_L		3	°C
Control Resistor Value Pin 3 to Pin 4 (See Table 1)	Rc	0		Ω
Control Temperature Range See Table 1	Tc	Ambient	120	°C
Turn on power at start-up	PON	See Figure 3		Watts

HEATER BLOCK DIAGRAM

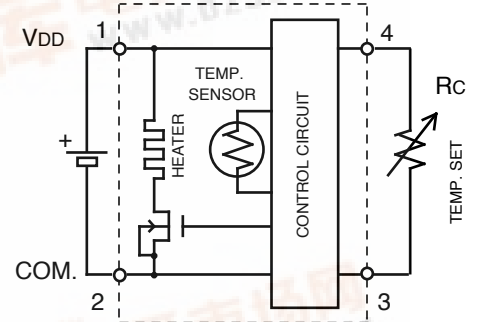

OUTLINE DIMENSIONS

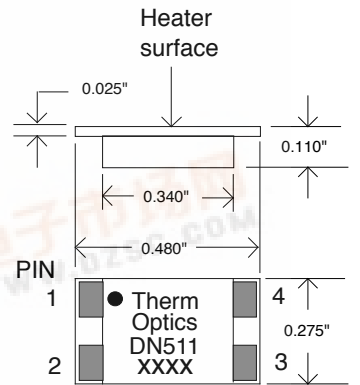

The DN511 electrical output pads are Pd-Pt-Ag and can be soldered. The solder used, such as SN-62, should contain silver to prevent leaching of the pads from the substrate.

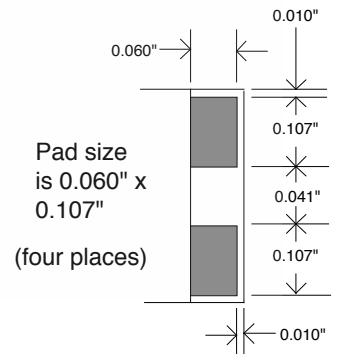

DN511

TYPICAL CASE TEMPERATURE VS CONTROL RESISTOR

RS KΩ	T °C	TOL. ±°C	RS KΩ	T °C	TOL. ±°C	RS KΩ	T °C	TOL. ±°C	RS KΩ	T °C	TOL. ±°C
360.1	0	3.0	79.6	29	2.5	20.2	58	3.0	4.6	87	3.5
340.6	1	3.0	75.8	30	2.5	19.3	59	3.0	4.4	88	3.5
322.3	2	3.0	72.2	31	2.5	18.4	60	3.0	4.1	89	3.5
305.0	3	3.0	68.8	32	2.5	17.5	61	3.5	3.9	90	3.5
288.7	4	3.0	65.5	33	2.5	16.7	62	3.5	3.6	91	3.5
273.4	5	3.0	62.5	34	2.5	15.9	63	3.5	3.4	92	3.5
259.0	6	3.0	59.5	35	2.5	15.2	64	3.5	3.2	93	3.5
245.4	7	3.0	56.8	36	2.5	14.5	65	3.5	3.0	94	3.5
232.5	8	3.0	54.1	37	2.5	13.8	66	3.5	2.8	95	3.5
220.4	9	3.0	51.6	38	2.5	13.2	67	3.5	2.6	96	3.5
209.0	10	3.0	49.2	39	2.5	12.5	68	3.5	2.4	97	3.5
198.3	11	2.5	46.9	40	2.5	11.9	69	3.5	2.2	98	3.5
188.1	12	2.5	44.8	41	3.0	11.4	70	3.5	2.0	99	3.5
178.5	13	2.5	42.7	42	3.0	10.8	71	3.5	1.8	100	3.5
169.4	14	2.5	40.7	43	3.0	10.3	72	3.5	1.68	101	3.5
160.8	15	2.5	38.9	44	3.0	9.8	73	3.5	1.52	102	3.5
152.7	16	2.5	37.1	45	3.5	9.3	74	3.5	1.37	103	3.5
145.1	17	2.5	35.4	46	3.0	8.9	75	3.5	1.23	104	3.5
137.8	18	2.5	33.8	47	3.0	8.4	76	3.5	1.09	105	3.5
131.0	19	2.5	33.8	47	3.0	8.0	77	3.5	0.95	106	3.5
124.5	20	2.5	30.8	49	3.0	7.6	78	3.5	0.82	107	3.5
118.3	21	2.5	29.4	50	3.0	7.2	79	3.5	0.70	108	3.5
112.5	22	2.5	28.1	51	3.0	6.8	80	3.5	0.58	109	3.5
107.0	23	2.5	26.8	52	3.0	6.5	81	3.5	0.46	110	3.5
101.8	24	2.5	25.5	53	3.0	6.1	82	3.5	0.35	111	3.5
96.9	25	2.5	24.4	54	3.0	5.8	83	3.5	0.25	112	3.5
92.2	26	2.5	23.2	55	3.0	5.5	84	3.5	0.14	113	3.5
87.8	27	2.5	22.2	56	3.0	5.2	85	3.5	0.04	114	3.5
83.6	28	2.5	21.2	57	3.0	4.9	86	3.5			

TYPICAL HEATER POWER AT TURN ON vs. POWER SUPPLY VOLTAGE

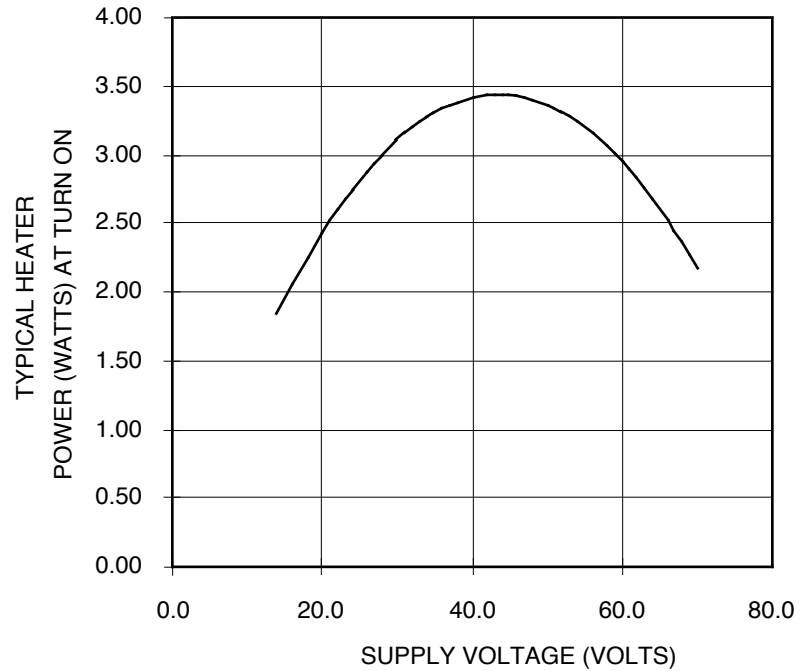

The temperature of the DN511 is supplied with four 3 inch #32 gage magnet wire as shown below. Temperature of the DN511 can be set at the factory on request

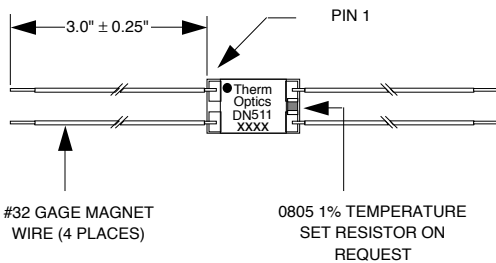

It is recommended that the DN511 heater be attached to the device being heated with a thermally conductive adhesive such as Loctite® 384. This will insure that there is minimum thermal resistance between the two surfaces.

MAXIMUM HEATER TURN ON CURRENT vs. POWER SUPPLY VOLTAGE

