



COMPOSANTS ÉLECTRONIQUES
ELECTRONIC COMPONENTS

DRA18 SERIES



AC - DC DIN RAIL MOUNTABLE
18W CLASS 2 POWER SUPPLY
INDUSTRIAL CONTROL EQUIPMENT

FEATURES

- UL / cUL / TUV / CE
- UNIVERSAL INPUT 90~265VAC
- HIGH EFFICIENCY UP TO 77%
- SHORT CIRCUIT PROTECTION
- INTERNAL INPUT FILTER
- 2 YEARS WARRANTY

MODEL LIST

MODEL NO.	INPUT VOLTAGE	OUTPUT WATTAGE	OUTPUT VOLTAGE	OUTPUT CURRENT	EFF. (typ.)	EFF. (min.)
Single Output Models						
DRA18-05	90~265 VAC	15 WATTS	+ 5 VDC	3000 mA	75%	73%
DRA18-12	90~265 VAC	18 WATTS	+ 12 VDC	1500 mA	77%	75%
DRA18-15	90~265 VAC	18 WATTS	+ 15 VDC	1200 mA	77%	75%
DRA18-24	90~265 VAC	18 WATTS	+ 24 VDC	750 mA	77%	75%

SPECIFICATION

All Specifications Typical At Nominal Line, Full Load, 25°C Unless Otherwise Noticed

GENERAL						
Characteristics	Conditions	min.	typ.	max.	unit	
Switching frequency	Vi nom, Io nom	100			KHz	
Isolation voltage	Input / Output	3,000			VAC	
Isolation resistance	Input / Output, @ 500VDC	100			MΩ	
Ambient temperature	Operating at Vi nom, Io 70%...100%	-10		+ 50	°C	
Derating	Vi nom, Io nom +51 to +71°C			2	% / °C	
Storage temperature	Non operational	-25		+ 85	°C	
M.T.B.F	According to MIL-HDBK-217F, GF40		195,000		Hrs	
Relative humidity	Vi nom, Io nom	20		95	% RH	
Dimension	L90 x W22.5 x D115				mm	
Cooling	Free air convection					
Case material	Plastic					

INPUT SPECIFICATIONS						
Characteristics	Conditions	min.	typ.	max.	unit	
Rated input voltage	Io nom	100		240	VAC	
Input voltage range	Ta min ... Ta max, Io nom	AC in		265	VAC	
		DC in	120		370	VDC
Line frequency	Vi nom, Io nom	47		63	Hz	
Inrush current	Io nom	Vi : 115VAC		10	A	
		Vi : 230VAC		18	A	





SPECIFICATION

All Specifications Typical At Nominal Line, Full Load, 25°C Unless Otherwise Noticed

OUTPUT SPECIFICATIONS

Characteristics	Conditions	min.	typ.	max.	unit
Output voltage accuracy	V_i nom, lo min ...lo nom			± 1	%
Minimum load	V_i nom	0			%
Line regulation	lo nom, V_i min ... V_i max			± 1	%
Load regulation	V_i nom, lo min ...lo nom			± 2	%
Transient recovery time	50% load step changed		300		μ S
Temperature coefficient	V_i nom, lo min			± 0.02	% / °C
Ripple & noise	V_i nom, lo nom, BW = 20MHz			50	mV
Hold up time	lo nom	$V_i = 115VAC$	20		ms
		$V_i = 230VAC$	75		ms
Voltage trim range	V_i nom, lo nom	5V ...15V models	- 10	+ 15	%
		24V model	- 10	+ 20	%
DC ON indicator threshold at start up	V_i nom, lo nom	5V model	4.5		VDC
		12V model	10.8		VDC
		15V model	13.5		VDC
		24V model	21.6		VDC
DC LOW indicator threshold after start up	V_i nom, lo nom	5V model	3.75	4.5	VDC
		12V model	9	10.8	VDC
		15V model	11.25	13.5	VDC
		24V model	18	21.6	VDC
Efficiency	V_i nom, lo nom, P_o / P_i	Up to 77%, See model list			

CONTROL AND PROTECTION

Characteristics	Conditions	min.	typ.	max.	unit
Input fuse		T2A / 250VAC internal			
Rated over load protection	V_i nom	110		135	%
Over voltage protection	V_i nom, lo nom	125		145	%
Output short circuit	V_i nom, lo nom	Hiccup mode			

APPROVALS AND STANDARDS

UL / cUL	UL508 / UL1310 Listed, Class 2 Power Supply
TUV	EN60950
CE	EN50081-1 / EN55022 for EMI
	EN50082-1 / EN55024 for EMS
FCC	Class B

CIRCUIT SCHEMATIC

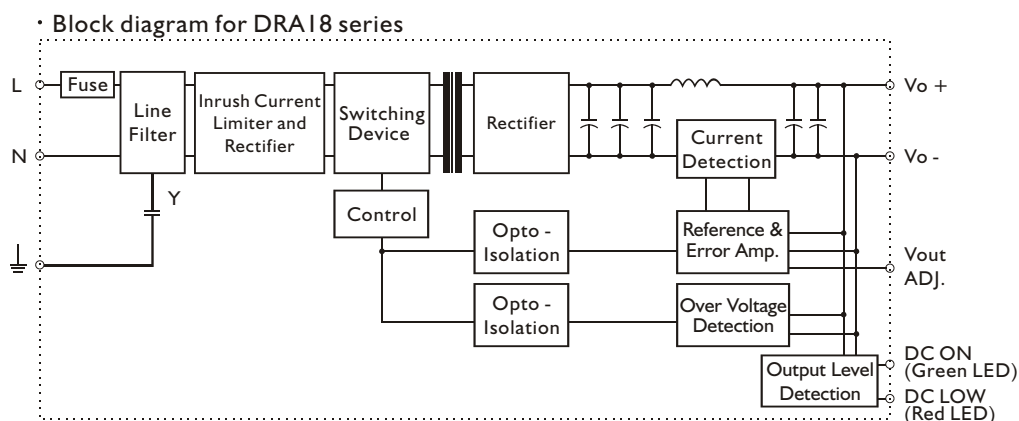



MECHANISM & PIN CONFIGURATION

mm [inch]

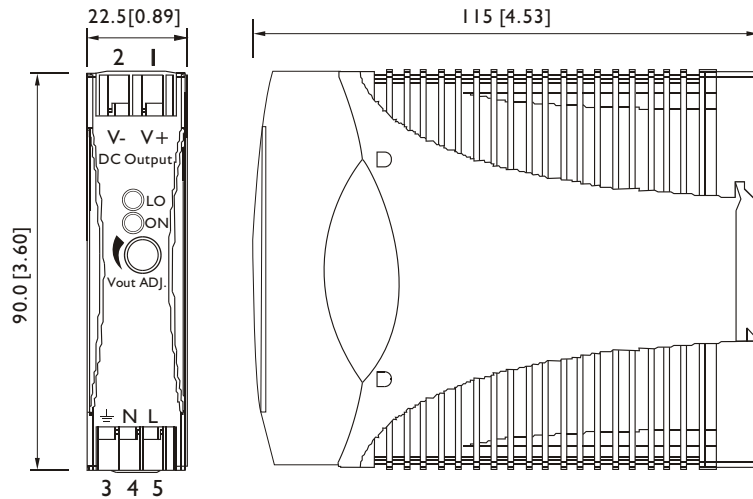

CONSTRUCTION

Easy snap-on mounting onto the DIN-Rail (TS35/7.5 or TS35/15), unit sits safely and firmly on the rail; no tools required even to remove

INSTALLATION

Ventilation / Cooling
Normal convection
Above/below 25m/m free space
For cooling recommended
Connector size range
Solid:0.2-2.0mm²(AWG24-14)
(use copper conductors only)

PHYSICAL CHARACTERISTICS

CASE SIZE	90 x 22.5 x 115 mm 3.6 x 0.89 x 4.53 inches
CASE MATERIAL	Plastic
WEIGHT	150 g

PIN ASSIGNMENT

PIN NO.		Designation	Description
1	OUT	V +	Positive output terminal
2		V -	Negative output terminal
3	IN	⊥	Ground this terminal to minimize high-frequency emissions
4		N	Input terminals (neutral conductor, no polarity at DC input)
5		L	Input terminals (phase conductor, no polarity at DC input)
	OTHER	ON	Operation indicator LED
		LO	DC LOW indicator LED
		Vout ADJ.	Trimmer-potentiometer for Vout adjustment

DERATING

