



DRV8800
DRV8801

DMOS FULL-BRIDGE MOTOR DRIVERS

FEATURES

- Low ON-Resistance [$R_{ds(ON)}$] Outputs
- Overcurrent Protection
- Motor Lead Short-to-Supply Protection
- Short-to-Ground Protection
- Low-Power Mode
- Synchronous Rectification
- Diagnostic Output
- Internal Undervoltage Lockout (UVLO)

- Crossover-Current Protection
- 16-Pin QFN With PowerPAD™ Package

APPLICATIONS

- Printers
- Industrial Automation

DESCRIPTION/ORDERING INFORMATION

Designed to control dc motors by using pulse width modulation (PWM), the DRV8800/DRV8801 is capable of peak output currents up to ± 2.8 A and operating voltages up to 36 V.

The PHASE and ENABLE inputs provide dc motor speed and direction control by applying external pulse-width modulation (PWM) and control signals. Internal synchronous rectification control circuitry provides lower power dissipation during PWM operation.

Internal circuit protection includes motor lead short-to-supply/short-to-ground, thermal shutdown with hysteresis, undervoltage monitoring of VBB and VCP, and crossover-current protection.

The DRV8800/DRV8801 is supplied in a thin-profile 16-pin QFN (RTY) PowerPAD™ package, providing enhanced thermal dissipation. The devices are lead free (Pb free).

ORDERING INFORMATION

T _A	PACKAGE ⁽¹⁾⁽²⁾	ORDERABLE PART NUMBER	TOP-SIDE MARKING
–20°C to 80°C	Plastic QFN 16 (S-PQFP-16) – RTY	DRV8800RTYR	DRV8800A0RTY
		DRV8800RTYT	DRV8800A0RTY
		DRV8801RTYR	DRV8801A0RTY
		DRV8801RTYT	DRV8801A0RTY

(1) For the most current package and ordering information, see the Package Option Addendum at the end of this document, or see the TI website at www.ti.com.

(2) Package drawings, thermal data, and symbolization are available at www.ti.com/packaging.

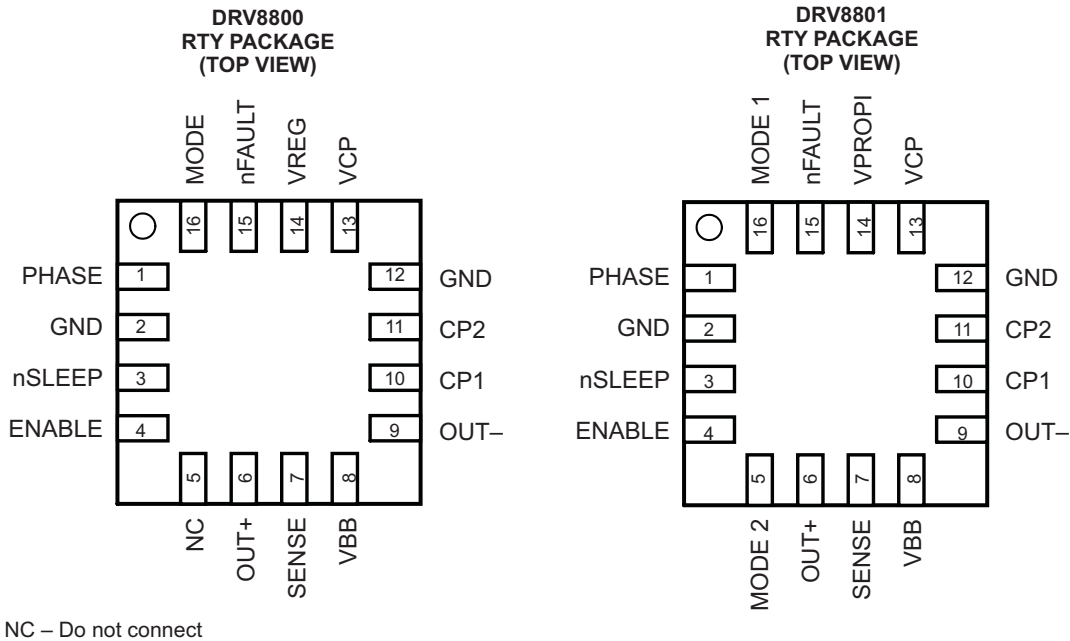

TERMINAL FUNCTIONS

NO.	TERMINAL		DESCRIPTION
	NAME		
	DRV8800	DRV8801	
1	PHASE	PHASE	Phase logic input for direction control
2	GND	GND	Ground
3	nSLEEP	nSLEEP	Sleep logic input
4	ENABLE	ENABLE	Enable logic input
5	NC	MODE 2	No connect (DRV8800), Mode 2 logic input (DRV8801)
6	OUTA	OUTA	DMOS full-bridge output A
7	SENSE	SENSE	Sense power return
8	VBB	VBB	Load supply voltage
9	OUTB	OUTB	DMOS full-bridge output B
10	CP1	CP1	Charge-pump capacitor 1
11	CP2	CP2	Charge-pump capacitor 2
12	GND	GND	Ground
13	VCP	VCP	Reservoir capacitor
14	VREG	VPROPI	Regulated voltage (DRV8800), Winding current proportional voltage output (DRV8801)
15	nFAULT	nFAULT	Fault open-drain output
16	MODE	MODE 1	Mode logic input
	PowerPAD	PowerPAD	Exposed pad for thermal dissipation connect to GND pins

DRV8800 TYPICAL APPLICATION DIAGRAM

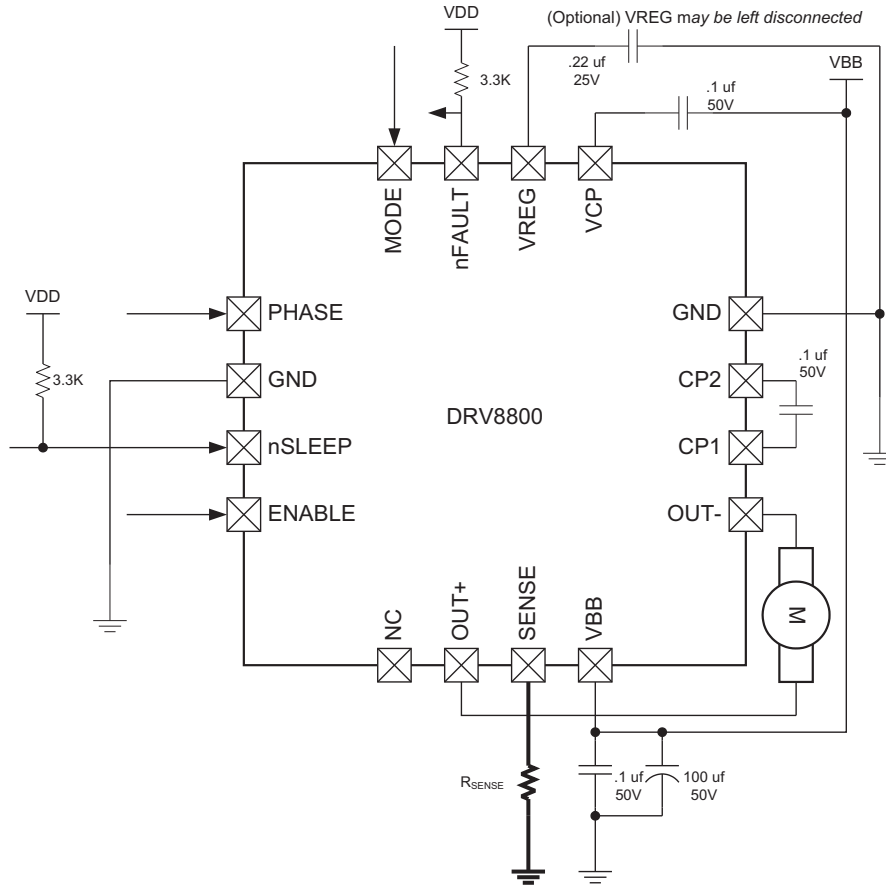

DRV8801 TYPICAL APPLICATION DIAGRAM

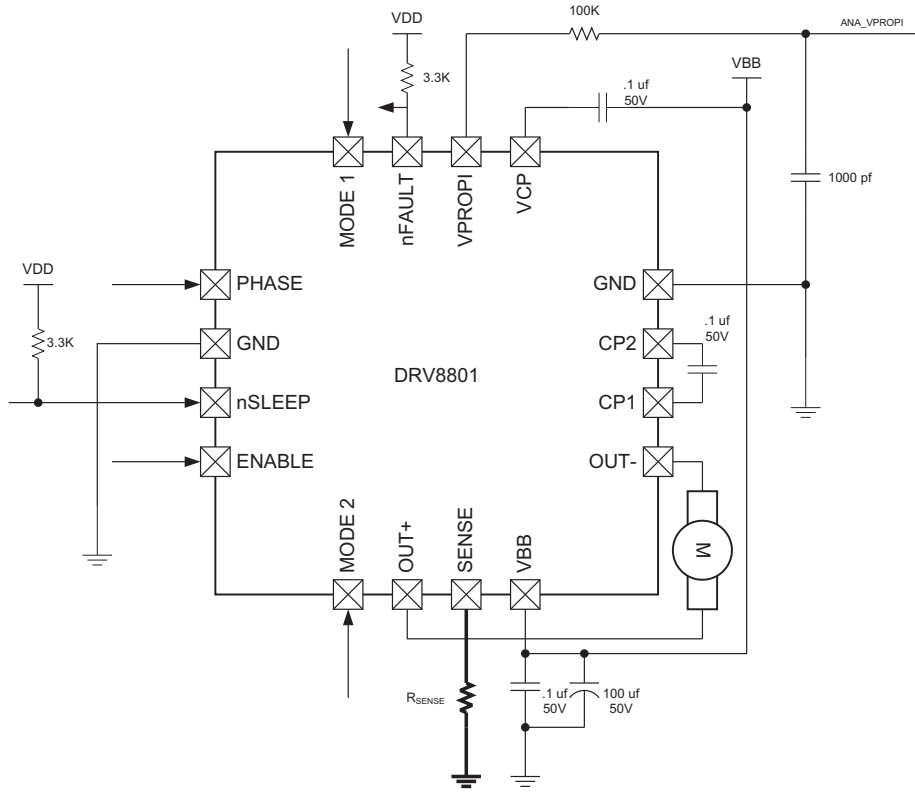

DRV8800 FUNCTIONAL BLOCK DIAGRAM

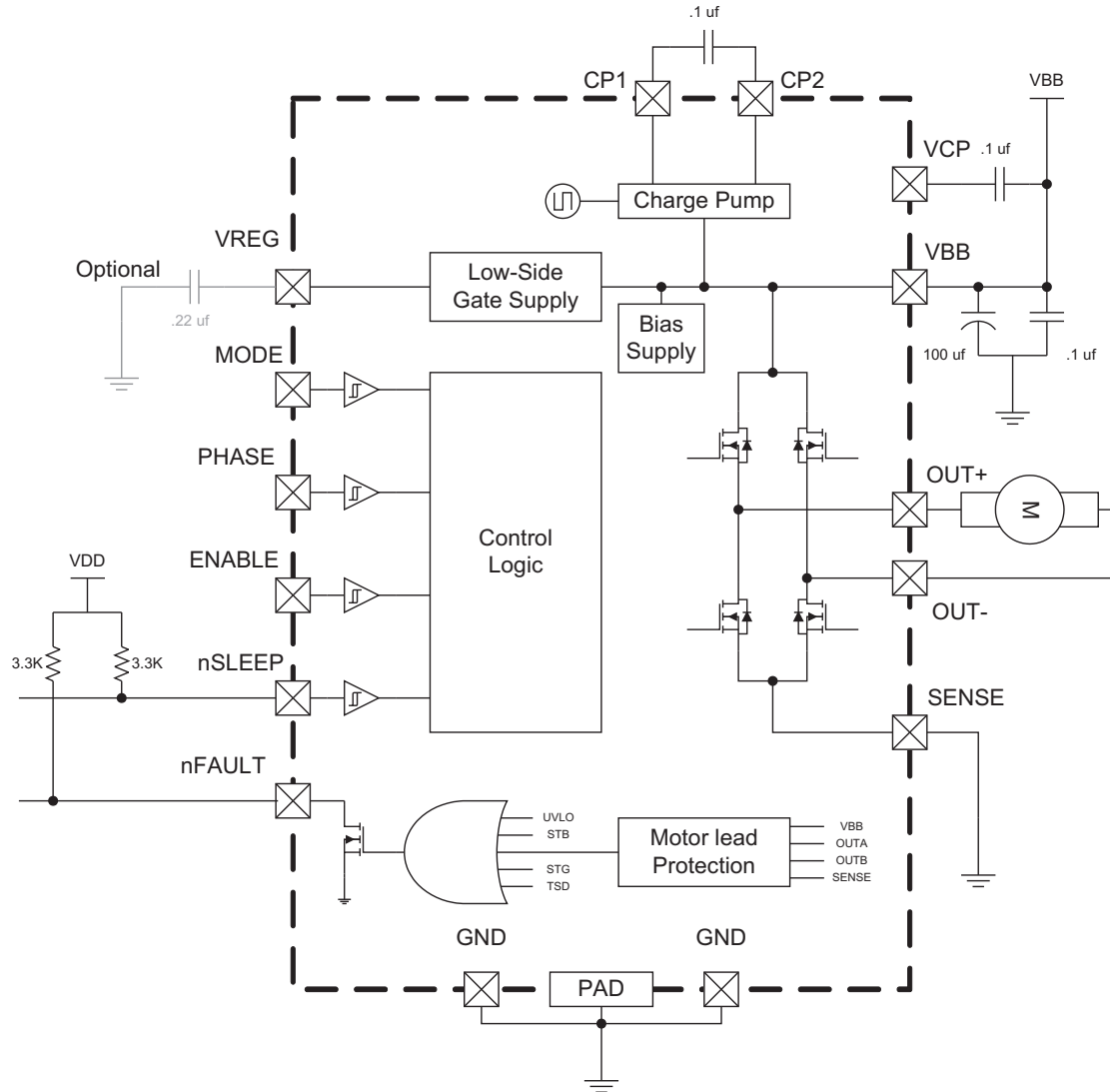

DRV8801 FUNCTIONAL BLOCK DIAGRAM

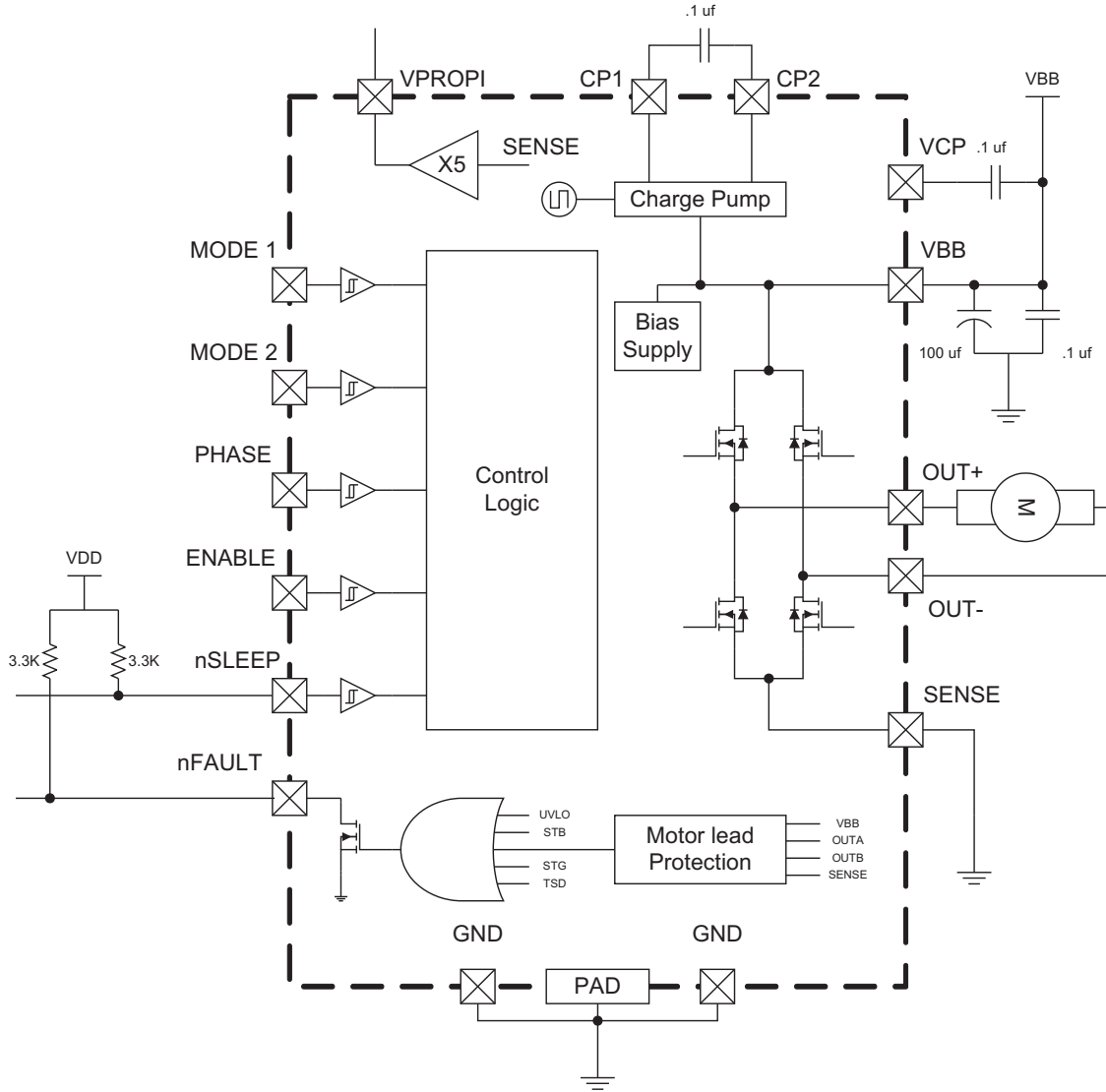

ABSOLUTE MAXIMUM RATINGS⁽¹⁾

over operating free-air temperature range (unless otherwise noted)

		MIN	MAX	UNIT
V _{BB}	Load supply voltage ⁽²⁾		40	V
	Output current		2.8	A
V _{Sense}	Sense voltage		±500	mV
	V _{BB} to OUTx		36	V
	OUTx to SENSE		36	V
V _{DD}	Logic input voltage ⁽²⁾	−0.3	7	V
ESD rating	Human-Body Model (HBM)		±2	kV
	Charged-Device Model (CDM)		500	V
	Continuous total power dissipation	See Dissipation Rating Table		
T _A	Operating free-air temperature range	−20	80	°C
T _J	Maximum junction temperature		190	°C
T _{stg}	Storage temperature range	−40	125	°C

- (1) Stresses beyond those listed under “absolute maximum ratings” may cause permanent damage to the device. These are stress ratings only, and functional operation of the device at these or any other conditions beyond those indicated under “recommended operating conditions” is not implied. Exposure to absolute-maximum-rated conditions for extended periods may affect device reliability.
- (2) All voltage values are with respect to network ground terminal.

DISSIPATION RATINGS

PACKAGE	θ_{JA}	T _A = 25°C POWER RATING	DERATING FACTOR ABOVE T _A = 25°C
RTY	41.6	3 W	24 mW/C

RECOMMENDED OPERATING CONDITIONS

		MIN	NOM	MAX	UNIT
V _{IN}	Input voltage, V _{BB}	8	32	38	V
T _A	Operating free-air temperature	−20	25	80	°C

ELECTRICAL CHARACTERISTICS

over recommended operating conditions (unless otherwise noted)

PARAMETER		TEST CONDITIONS	MIN	TYP	MAX	UNIT
IBB	Motor supply current	$f_{PWM} < 50 \text{ kHz}$		6		mA
		Charge pump on, Outputs disabled		3.2		
		Sleep mode				10
V_{IH}	PHASE, ENABLE, MODE input voltage		2			V
V_{IL}				0.8		
V_{IH}	nSLEEP input voltage		2.7			V
V_{IL}				0.8		
I_{IH}	PHASE, MODE input current 1	$V_{IN} = 2 \text{ V}$		<1.0	20	μA
I_{IL}		$V_{IN} = 0.8 \text{ V}$	-20	≤ -2.0	20	
I_{IH}	ENABLE input current	$V_{IN} = 2 \text{ V}$		40	100	μA
I_{IL}		$V_{IN} = 0.8 \text{ V}$		16	40	
I_{IH}	nSLEEP input current	$V_{IN} = 2.7 \text{ V}$		27	50	μA
I_{IL}		$V_{IN} = 0.8 \text{ V}$		<1	10	
V_{OL}	nFAULT output voltage	$I_{sink} = 1 \text{ mA}$			0.4	V
VBBNFR	VBB nFAULT release	$8 \text{ V} < V_{BB} < 40 \text{ V}$		12	13.8	V
V_{IHys}	Input hysteresis, except nSLEEP		100	500	800	mV
$R_{ds(ON)}$	Output ON resistance	Source driver, $I_{OUT} = -2.8 \text{ A}$, $T_J = 25^\circ\text{C}$		0.35	0.48	Ω
		Source driver, $I_{OUT} = -2.8 \text{ A}$, $T_J = 125^\circ\text{C}$		0.55	0.8	
		Sink driver, $I_{OUT} = 2.8 \text{ A}$, $T_J = 25^\circ\text{C}$		0.3	0.43	
		Sink driver, $I_{OUT} = 2.8 \text{ A}$, $T_J = 125^\circ\text{C}$		0.45	0.7	
VTRP	RSENSE/ISense voltage trip	SENSE connected to ground through some resistance		500		mV
V_f	Body diode forward voltage 1	Source diode, $I_f = -2.8 \text{ A}$			1.4	V
		Sink diode, $I_f = 2.8 \text{ A}$			1.4	
t_{pd}	Propagation delay time	PWM, Change to source or sink ON		600		ns
		PWM, Change to source or sink OFF		100		
t_{COD}	Crossover delay			500		ns
DAGain	Differential AMP gain	Sense = 0.1 V to 0.4 V		5		V/V
Protection Circuitry						
VUV	UVLO threshold	VBB increasing		6.5	8	V
IOCP	Overcurrent threshold 2		3			A
t_{OCP}	Overcurrent protection period			1.2		ms
TJW	Thermal warning temperature	Temperature increasing		160		$^\circ\text{C}$
TJWHys	Thermal warning hysteresis	Recovery = TJW – TJWHys		15		$^\circ\text{C}$
TJTSD	Thermal shutdown temperature	Temperature increasing		175		$^\circ\text{C}$
TJTSDHys	Thermal shutdown hysteresis	Recovery = TJTSD – TJTSDHys		15		$^\circ\text{C}$

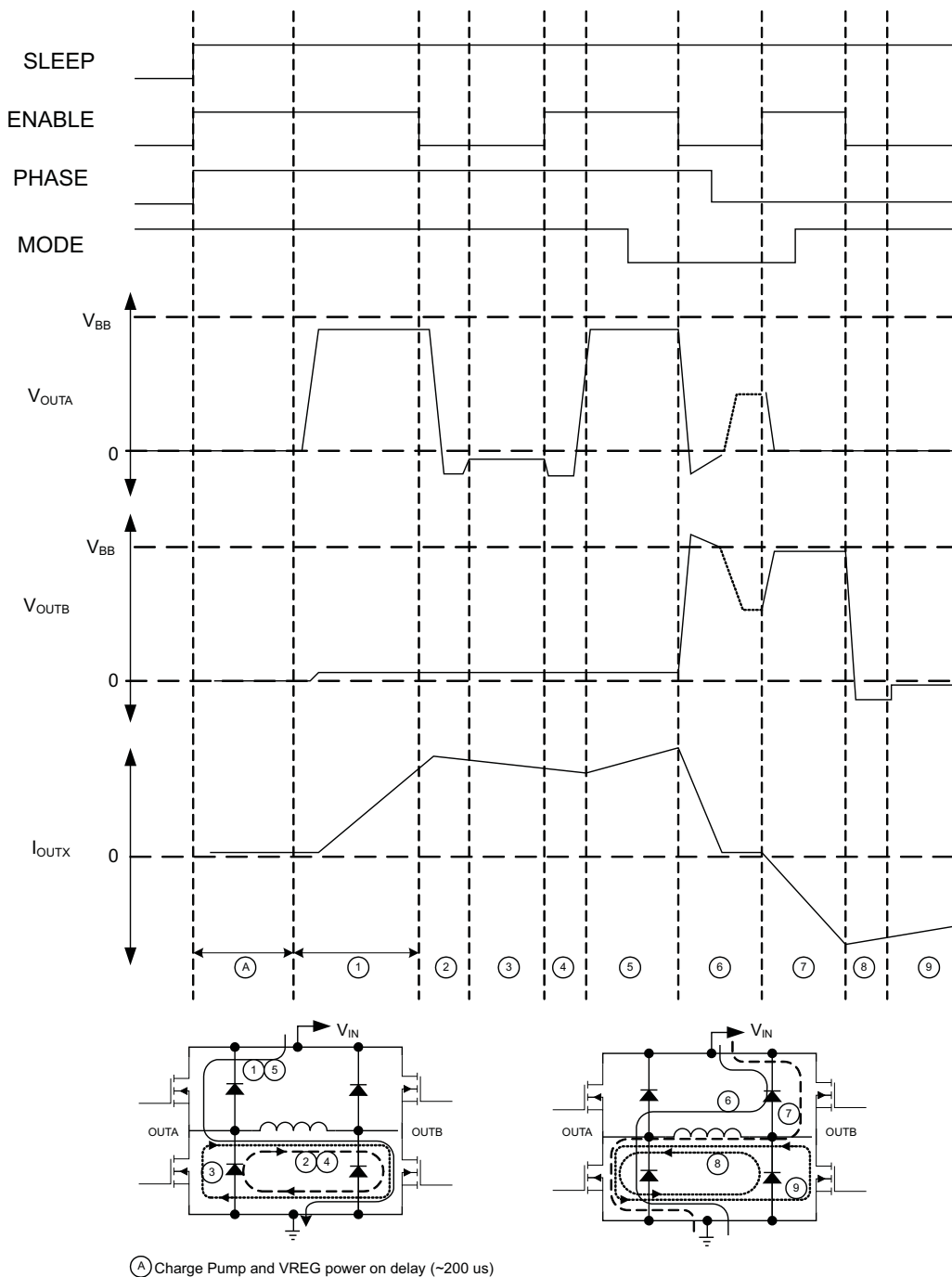

Figure 1. PWM Control Timing

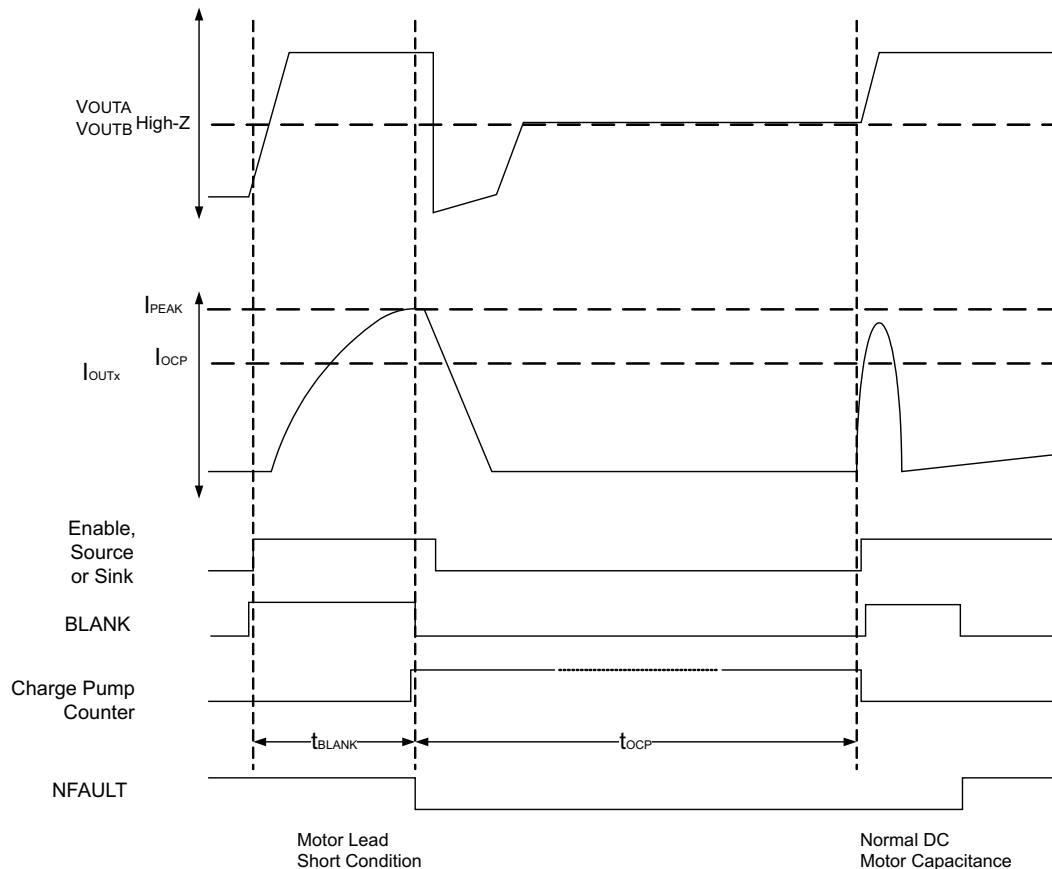

Figure 2. Overcurrent Control Timing

FUNCTIONAL DESCRIPTION

Device Operation

The DRV8800/DRV8801 is designed to drive one dc motor. The current through the output full-bridge switches and all N-channel DMOS are regulated with a fixed off-time PWM control circuit.

Logic Inputs

It is recommended to use a high-value pullup resistor when logic inputs are pulled up to V_{DD} . This resistor limits the current to the input in case an overvoltage event occurs. Logic inputs are nSLEEP, MODE, PHASE, and ENABLE. Voltages higher than 7 V on any logic input can cause damage to the input structure.

VREG (DRV8800 Only)

This output represents a measurement of the internal regulator voltage. This pin should be left disconnected. A voltage of approximately 7.5 V can be measured at this pin.

VPROPI (DRV8801 Only)

This output offers an analog voltage proportional to the winding current. Voltage at this terminal is five times greater than the motor winding current ($V_{PROPI} = 5 \times I$). VPROPI is meaningful only if there is a resistor connected to the SENSE pin. If SENSE is connected to ground, VPROPI measures 0 V. During slow decay, VPROPI outputs 0 V. VPROPI can output a maximum of 2.5 V, since at 500 mV on SENSE, the H-bridge is disabled.

Charge Pump

The charge pump is used to generate a supply above VBB to drive the source-side DMOS gates. A 0.1- μ F ceramic monolithic capacitor should be connected between CP1 and CP2 for pumping purposes. A 0.1- μ F ceramic monolithic capacitor, CStorage, should be connected between VCP and VBB to act as a reservoir to run the high-side DMOS devices. The VCP voltage level is internally monitored and, in the case of a fault condition, the outputs of the device are disabled.

Shutdown

As a measure to protect the device, faults caused by very high junction temperatures or low voltage on VCP disable the outputs of the device until the fault condition is removed. At power on, the UVLO circuit disables the drivers.

Low-Power Mode

Control input nSLEEP is used to minimize power consumption when the DRV8800/DRV8801 is not in use. This disables much of the internal circuitry, including the internal voltage rails and charge pump. nSLEEP is asserted low. A logic high on this input pin results in normal operation. When switching from low to high, the user should allow a 1-ms delay before applying PWM signals. This time is needed for the charge pump to stabilize.

- MODE 1 (MODE on the DRV8800)
Input MODE 1 is used to toggle between fast-decay mode and slow-decay mode. A logic high puts the device in slow-decay mode.
- MODE 2 (DRV8801 only)
MODE 2 is used to select which set of drivers (high side versus low side) is used during the slow-decay recirculation. MODE 2 is meaningful only when MODE 1 is asserted high. A logic high on MODE 2 has current recirculation through the high-side drivers. A logic low has current recirculation through the low-side drivers.

Braking

The braking function is implemented by driving the device in slow-decay mode (MODE 1 pin is high) and deasserting the enable to low. Because it is possible to drive current in both directions through the DMOS switches, this configuration effectively shorts out the motor-generated BEMF as long as the ENABLE chop mode is asserted. The maximum current can be approximated by V_{BEMF}/R_L . Care should be taken to ensure that the maximum ratings of the device are not exceeded in worse-case braking situations – high-speed and high-inertia loads.

Diagnostic Output

The nFAULT pin signals a problem with the chip via an open-drain output. A motor fault, undervoltage condition, or $T_J > 160^\circ\text{C}$ drives the pin active low. This output is not valid when nSLEEP puts the device into minimum power dissipation mode (i.e., nSLEEP is low). nFAULT stays asserted (nFAULT = L) until VBB reaches VBBNFR to give the charge pump headroom to reach its undervoltage threshold. nFAULT is a status-only signal and does not affect any device functionality. The H-bridge portion still operates normally down to $V_{BB} = 8\text{ V}$ with nFAULT asserted.

Thermal Shutdown (TSD)

Two die-temperature monitors are integrated on the chip. As die temperature increases toward the maximum, a thermal warning signal is triggered at 160°C . This fault drives the nFAULT low, but does not disable the operation of the chip. If the die temperature increases further, to approximately 175°C , the full-bridge outputs are disabled until the internal temperature falls below a hysteresis of 15°C .

Control Logic Table⁽¹⁾

PHASE	ENABLE	PINS					OPERATION
		MODE 1	MODE 2	nSLEEP	OUTA	OUTB	
1	1	X	X	1	H	L	Forward
0	1	X	X	1	L	H	Reverse
X	0	1	0	1	L	L	Brake (slow decay)
1	0	0	1	1	L	H	Fast-decay synchronous rectification ⁽²⁾
0	0	0	X	1	H	L	Fast-decay synchronous rectification ⁽²⁾
X	X	X	X	0	Z	Z	Sleep mode

(1) X = Don't care, Z = high impedance

(2) To prevent reversal of current during fast-decay synchronous rectification, outputs go to the high-impedance state as the current approaches 0 A.

Overcurrent Protection

The current flowing through the high-side and low-side drivers is monitored to ensure that the motor lead is not shorted to supply or ground. If a short is detected, the full-bridge outputs are turned off, flag nFAULT is driven low, and a 1.2-ms fault timer is started. After this 1.2-ms period, t_{OCP} , the device is then allowed to follow the input commands and another turnon is attempted (nFAULT becomes high again during this attempt). If there is still a fault condition, the cycle repeats. If after t_{OCP} expires it is determined the short condition is not present, normal operation resumes and nFAULT is deasserted.

APPLICATION INFORMATION

Power Dissipation

First-order approximation of power dissipation in the DRV8800/DRV8801 can be calculated by examining the power dissipation in the full-bridge during each of the operation modes. DRV8800/DRV8801 utilize synchronous rectification. During the decay cycle, the body diode is shorted by the low- $R_{ds(ON)}$ driver, which in turn reduces power dissipation in the full-bridge. In order to prevent shoot through (high-side and low-side drivers on the same side are ON at the same time), DRV8800/DRV8801 implement a 500-ns typical crossover delay time. During this period, the body diode in the decay current path conducts the current until the DMOS driver turns on. High current and high ambient temperature applications should take this into consideration. In addition, motor parameters and switching losses can add power dissipation that could affect critical applications.

Drive Current

This current path is through the high-side sourcing DMOS driver, motor winding, and low-side sinking DMOS driver. Power dissipation I^2R losses in one source and one sink DMOS driver, as shown in Equation 1.

$$P_D = I^2 (R_{DS(on)Source} + R_{DS(on)Sink}) \quad (1)$$

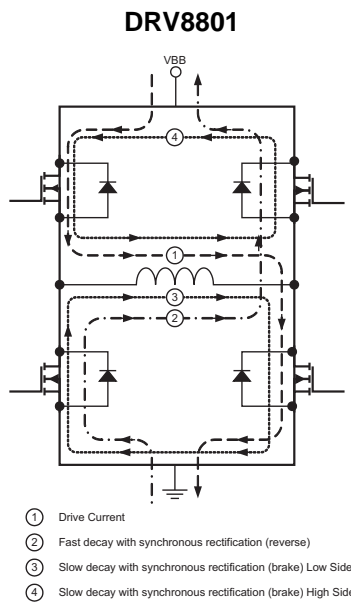
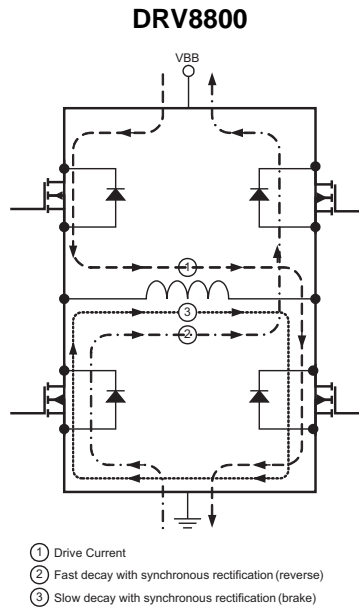

Figure 3. Current Path

Fast Decay With Synchronous Rectification

This decay mode is equivalent to a phase change where the opposite drivers are switched on. When in fast decay, the motor current is not allowed to go negative (direction change). Instead, as the current approaches zero, the drivers turn off. The power calculation is the same as the drive current calculation (see Equation 1).

Slow-Decay SR (Brake Mode)

In slow-decay mode, both low-side sinking drivers turn on, allowing the current to circulate through the H-bridge's low side (two sink drivers) and the load. Power dissipation I^2R losses in the two sink DMOS drivers:

$$P_D = I^2(2 \times R_{DS(on)Sink}) \quad (2)$$

SENSE

A low-value resistor can be placed between the SENSE pin and ground for current-sensing purposes. To minimize ground-trace IR drops in sensing the output current level, the current-sensing resistor should have an independent ground return to the star ground point. This trace should be as short as possible. For low-value sense resistors, the IR drops in the PCB can be significant, and should be taken into account.

NOTE:

When selecting a value for the sense resistor, SENSE does not exceed the maximum voltage of ± 500 mV. The H-bridge is disabled and enters recirculation while motor winding current is above a SENSE voltage equal or greater than 500 mV.

Ground

A ground power plane should be located as close to the DRV8800/DRV8801 as possible. The copper ground plane directly under the PowerPAD package makes a good location. This pad can then be connected to ground for this purpose.

Layout

The printed circuit board (PCB) should use a heavy ground plane. For optimum electrical and thermal performance, the DRV8800/DRV8801 must be soldered directly onto the board. On the underside of the DRV8800/DRV8801 is a PowerPAD package, which provides a path for enhanced thermal dissipation. The thermal pad should be soldered directly to an exposed surface on the PCB. Thermal vias are used to transfer heat to other layers of the PCB. For more information on this technique, please refer to document SLMA002.

The load supply pin, VBB, should be decoupled with an electrolytic capacitor (typically 100 μ F) in parallel with a ceramic capacitor placed as close as possible to the device. The ceramic capacitors between VCP and VBB, connected to VREG, and between CP1 and CP2 should be as close to the pins of the device as possible, in order to minimize lead inductance.

PACKAGING INFORMATION

Orderable Device	Status ⁽¹⁾	Package Type	Package Drawing	Pins	Package Qty	Eco Plan ⁽²⁾	Lead/Ball Finish	MSL Peak Temp ⁽³⁾
DRV8800RTYR	ACTIVE	QFN	RTY	16	3000	Green (RoHS & no Sb/Br)	CU NIPDAU	Level-3-260C-168 HR
DRV8800RTYT	ACTIVE	QFN	RTY	16	250	Green (RoHS & no Sb/Br)	CU NIPDAU	Level-3-260C-168 HR
DRV8801RTYR	ACTIVE	QFN	RTY	16	3000	Green (RoHS & no Sb/Br)	CU NIPDAU	Level-3-260C-168 HR
DRV8801RTYT	ACTIVE	QFN	RTY	16	250	Green (RoHS & no Sb/Br)	CU NIPDAU	Level-3-260C-168 HR

⁽¹⁾ The marketing status values are defined as follows:

ACTIVE: Product device recommended for new designs.

LIFEBUY: TI has announced that the device will be discontinued, and a lifetime-buy period is in effect.

NRND: Not recommended for new designs. Device is in production to support existing customers, but TI does not recommend using this part in a new design.

PREVIEW: Device has been announced but is not in production. Samples may or may not be available.

OBSELETE: TI has discontinued the production of the device.

⁽²⁾ Eco Plan - The planned eco-friendly classification: Pb-Free (RoHS), Pb-Free (RoHS Exempt), or Green (RoHS & no Sb/Br) - please check <http://www.ti.com/productcontent> for the latest availability information and additional product content details.

TBD: The Pb-Free/Green conversion plan has not been defined.

Pb-Free (RoHS): TI's terms "Lead-Free" or "Pb-Free" mean semiconductor products that are compatible with the current RoHS requirements for all 6 substances, including the requirement that lead not exceed 0.1% by weight in homogeneous materials. Where designed to be soldered at high temperatures, TI Pb-Free products are suitable for use in specified lead-free processes.

Pb-Free (RoHS Exempt): This component has a RoHS exemption for either 1) lead-based flip-chip solder bumps used between the die and package, or 2) lead-based die adhesive used between the die and leadframe. The component is otherwise considered Pb-Free (RoHS compatible) as defined above.

Green (RoHS & no Sb/Br): TI defines "Green" to mean Pb-Free (RoHS compatible), and free of Bromine (Br) and Antimony (Sb) based flame retardants (Br or Sb do not exceed 0.1% by weight in homogeneous material)

⁽³⁾ MSL, Peak Temp. -- The Moisture Sensitivity Level rating according to the JEDEC industry standard classifications, and peak solder temperature.

Important Information and Disclaimer:The information provided on this page represents TI's knowledge and belief as of the date that it is provided. TI bases its knowledge and belief on information provided by third parties, and makes no representation or warranty as to the accuracy of such information. Efforts are underway to better integrate information from third parties. TI has taken and continues to take reasonable steps to provide representative and accurate information but may not have conducted destructive testing or chemical analysis on incoming materials and chemicals. TI and TI suppliers consider certain information to be proprietary, and thus CAS numbers and other limited information may not be available for release.

In no event shall TI's liability arising out of such information exceed the total purchase price of the TI part(s) at issue in this document sold by TI to Customer on an annual basis.

TAPE AND REEL INFORMATION

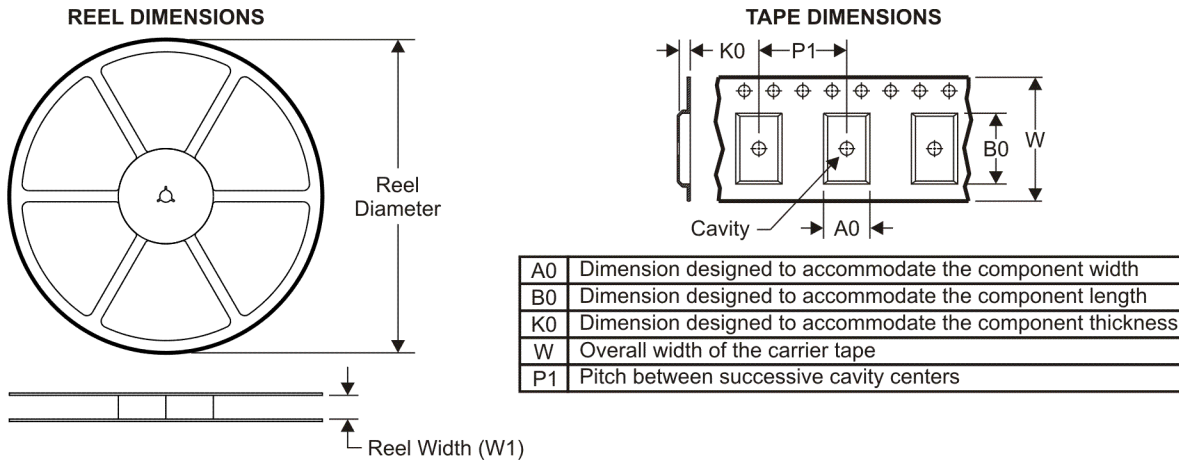

QUADRANT ASSIGNMENTS FOR PIN 1 ORIENTATION IN TAPE

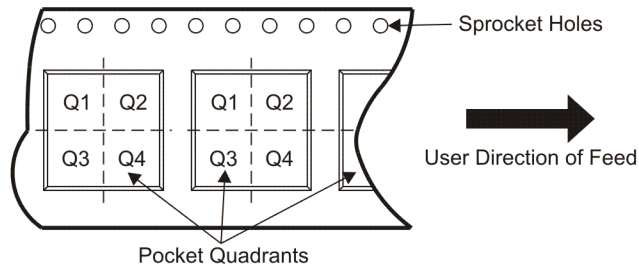

*All dimensions are nominal

Device	Package Type	Package Drawing	Pins	SPQ	Reel Diameter (mm)	Reel Width W1 (mm)	A0 (mm)	B0 (mm)	K0 (mm)	P1 (mm)	W (mm)	Pin1 Quadrant
DRV8800RTYR	QFN	RTY	16	3000	330.0	12.4	4.3	4.3	1.5	8.0	12.0	Q1
DRV8800RTYT	QFN	RTY	16	250	180.0	12.4	4.3	4.3	1.5	8.0	12.0	Q1
DRV8801RTYR	QFN	RTY	16	3000	330.0	12.4	4.3	4.3	1.5	8.0	12.0	Q1
DRV8801RTYT	QFN	RTY	16	250	180.0	12.4	4.3	4.3	1.5	8.0	12.0	Q1

TAPE AND REEL BOX DIMENSIONS

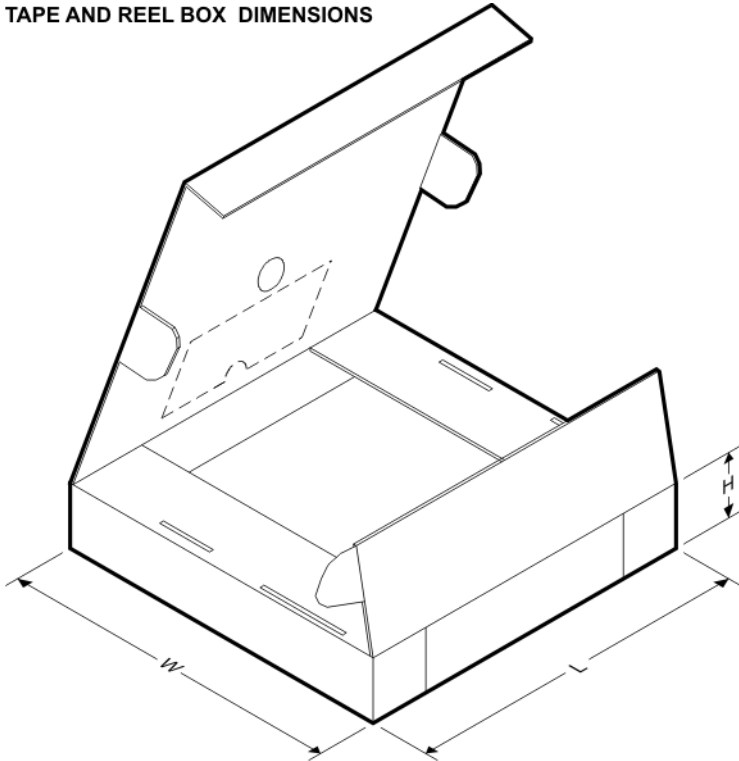

*All dimensions are nominal

Device	Package Type	Package Drawing	Pins	SPQ	Length (mm)	Width (mm)	Height (mm)
DRV8800RTYR	QFN	RTY	16	3000	346.0	346.0	29.0
DRV8800RTYT	QFN	RTY	16	250	190.5	212.7	31.8
DRV8801RTYR	QFN	RTY	16	3000	346.0	346.0	29.0
DRV8801RTYT	QFN	RTY	16	250	190.5	212.7	31.8

IMPORTANT NOTICE

Texas Instruments Incorporated and its subsidiaries (TI) reserve the right to make corrections, modifications, enhancements, improvements, and other changes to its products and services at any time and to discontinue any product or service without notice. Customers should obtain the latest relevant information before placing orders and should verify that such information is current and complete. All products are sold subject to TI's terms and conditions of sale supplied at the time of order acknowledgment.

TI warrants performance of its hardware products to the specifications applicable at the time of sale in accordance with TI's standard warranty. Testing and other quality control techniques are used to the extent TI deems necessary to support this warranty. Except where mandated by government requirements, testing of all parameters of each product is not necessarily performed.

TI assumes no liability for applications assistance or customer product design. Customers are responsible for their products and applications using TI components. To minimize the risks associated with customer products and applications, customers should provide adequate design and operating safeguards.

TI does not warrant or represent that any license, either express or implied, is granted under any TI patent right, copyright, mask work right, or other TI intellectual property right relating to any combination, machine, or process in which TI products or services are used. Information published by TI regarding third-party products or services does not constitute a license from TI to use such products or services or a warranty or endorsement thereof. Use of such information may require a license from a third party under the patents or other intellectual property of the third party, or a license from TI under the patents or other intellectual property of TI.

Reproduction of TI information in TI data books or data sheets is permissible only if reproduction is without alteration and is accompanied by all associated warranties, conditions, limitations, and notices. Reproduction of this information with alteration is an unfair and deceptive business practice. TI is not responsible or liable for such altered documentation. Information of third parties may be subject to additional restrictions.

Resale of TI products or services with statements different from or beyond the parameters stated by TI for that product or service voids all express and any implied warranties for the associated TI product or service and is an unfair and deceptive business practice. TI is not responsible or liable for any such statements.

TI products are not authorized for use in safety-critical applications (such as life support) where a failure of the TI product would reasonably be expected to cause severe personal injury or death, unless officers of the parties have executed an agreement specifically governing such use. Buyers represent that they have all necessary expertise in the safety and regulatory ramifications of their applications, and acknowledge and agree that they are solely responsible for all legal, regulatory and safety-related requirements concerning their products and any use of TI products in such safety-critical applications, notwithstanding any applications-related information or support that may be provided by TI. Further, Buyers must fully indemnify TI and its representatives against any damages arising out of the use of TI products in such safety-critical applications.

TI products are neither designed nor intended for use in military/aerospace applications or environments unless the TI products are specifically designated by TI as military-grade or "enhanced plastic." Only products designated by TI as military-grade meet military specifications. Buyers acknowledge and agree that any such use of TI products which TI has not designated as military-grade is solely at the Buyer's risk, and that they are solely responsible for compliance with all legal and regulatory requirements in connection with such use.

TI products are neither designed nor intended for use in automotive applications or environments unless the specific TI products are designated by TI as compliant with ISO/TS 16949 requirements. Buyers acknowledge and agree that, if they use any non-designated products in automotive applications, TI will not be responsible for any failure to meet such requirements.

Following are URLs where you can obtain information on other Texas Instruments products and application solutions:

Products

Amplifiers	amplifier.ti.com
Data Converters	dataconverter.ti.com
DSP	dsp.ti.com
Clocks and Timers	www.ti.com/clocks
Interface	interface.ti.com
Logic	logic.ti.com
Power Mgmt	power.ti.com
Microcontrollers	microcontroller.ti.com
RFID	www.ti-rfid.com
RF/IF and ZigBee® Solutions	www.ti.com/lprf

Applications

Audio	www.ti.com/audio
Automotive	www.ti.com/automotive
Broadband	www.ti.com/broadband
Digital Control	www.ti.com/digitalcontrol
Medical	www.ti.com/medical
Military	www.ti.com/military
Optical Networking	www.ti.com/opticalnetwork
Security	www.ti.com/security
Telephony	www.ti.com/telephony
Video & Imaging	www.ti.com/video
Wireless	www.ti.com/wireless

Mailing Address: Texas Instruments, Post Office Box 655303, Dallas, Texas 75265
Copyright © 2008, Texas Instruments Incorporated