

PRELIMINARY



# DS2760 High Precision Li-Ion Battery Monitor

www.dalsemi.com

## FEATURES

- Li-Ion safety circuit
  - Overvoltage protection
  - Overcurrent/short circuit protection
  - Undervoltage protection
- Available in two configurations:
  - Internal 25 mΩ sense resistor
  - External user-selectable sense resistor
- Current measurement
  - 12-bit bi-directional measurement
  - Internal sense resistor configuration:  
0.625 mA LSB and ±1.8A dynamic range
  - External sense resistor configuration:  
15.625 μV LSB and ±64 mV dynamic range
- Current accumulation
  - Internal sense resistor: 0.25 mAhr LSB
  - External sense resistor: 6.25 μVhr LSB
- Voltage measurement with 4.88 mV resolution
- Temperature measurement using integrated sensor with 0.125°C resolution
- System power management and control feature support
- 32 bytes of lockable EEPROM
- 16 bytes of general purpose SRAM
- Dallas 1-Wire® interface with unique 64-bit device address
- Low power consumption:
  - Active current: 80 μA max
  - Sleep current: 2 μA max

## PIN ASSIGNMENT

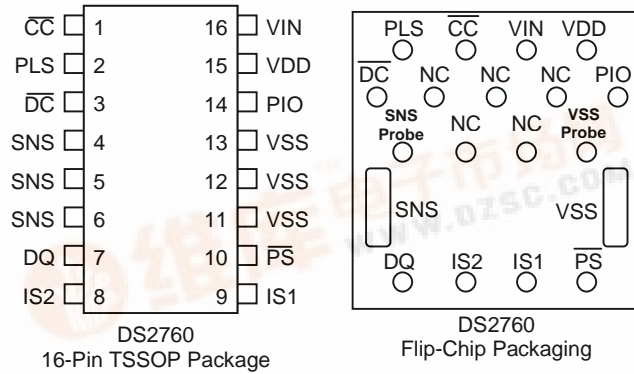

## PIN DESCRIPTION

- CC - Charge control output
- DC - Discharge control output
- DQ - Data input/output
- PIO - Programmable I/O pin
- PLS - Battery pack positive terminal input
- PS - Power switch sense input
- VIN - Voltage sense input
- VDD - Power supply input (2.5V-5.5V)
- VSS - Device ground
- SNS - Sense resistor connection
- IS1 - Current sense input
- IS2 - Current sense input
- NC - Not connected
- SNS Probe - Do not connect
- VSS Probe - Do not connect



## ORDERING INFORMATION

DS2760E	TSSOP, External Sense Res., 4.35V $V_{OV}$	DS2760T-025	DS2760E-025 in Tape & Reel
DS2760EA	TSSOP, External Sense Res., 4.275V $V_{OV}$	DS2760TA-025	DS2760EA-025 in Tape & Reel
DS2760T	DS2760E on Tape & Reel	DS2760X	Flipchip, Ext. Sense Res., T&R, 4.35V $V_{OV}$
DS2760TA	DS2760EA on Tape & Reel	DS2760XA	Flipchip, Ext. Sense Res., T&R, 4.275V $V_{OV}$
DS2760E-025	TSSOP, 25 m $\Omega$ Sense Res., 4.35V $V_{OV}$	DS2760X-025	Flipchip, 25 m $\Omega$ Sense Res., T&R, 4.35V $V_{OV}$
DS2760EA-025	TSSOP, 25 m $\Omega$ Sense Res., 4.275V $V_{OV}$	DS2760XA-025	Flipchip, 25 m $\Omega$ Sense Res., T&R, 4.275V $V_{OV}$

## DESCRIPTION

The DS2760 High Precision Li-Ion Battery Monitor is a data acquisition, information storage, and safety protection device tailored for cost-sensitive battery pack applications. This low-power device integrates precise temperature, voltage, and current measurement, nonvolatile data storage, and Li-Ion protection into the small footprint of either a TSSOP package or flip-chip. The DS2760 is a key component in applications including remaining capacity estimation, safety monitoring, and battery-specific data storage.

Via its 1-Wire interface, the DS2760 gives the host system read/write access to status and control registers, instrumentation registers, and general purpose data storage. Each device has a factory-programmed 64-bit net address which allows it to be individually addressed by the host system, supporting multi-battery operation.

The DS2760 is capable of performing temperature, voltage and current measurement to a resolution sufficient to support process monitoring applications such as battery charge control, remaining capacity estimation, and safety monitoring. Temperature is measured using an on-chip sensor, eliminating the need for a separate thermistor. Bi-directional current measurement and accumulation are accomplished using either an internal 25 m $\Omega$  sense resistor or an external device. The DS2760 also features a programmable I/O pin that allows the host system to sense and control other electronics in the pack, including switches, vibration motors, speakers and LEDs.

Three types of memory are provided on the DS2760 for battery information storage: EEPROM, lockable EEPROM and SRAM. EEPROM memory saves important battery data in true nonvolatile memory that is unaffected by severe battery depletion, accidental shorts or ESD events. Lockable EEPROM becomes ROM when locked to provide additional security for unchanging battery data. SRAM provides inexpensive storage for temporary data.

**BLOCK DIAGRAM – Figure 1**

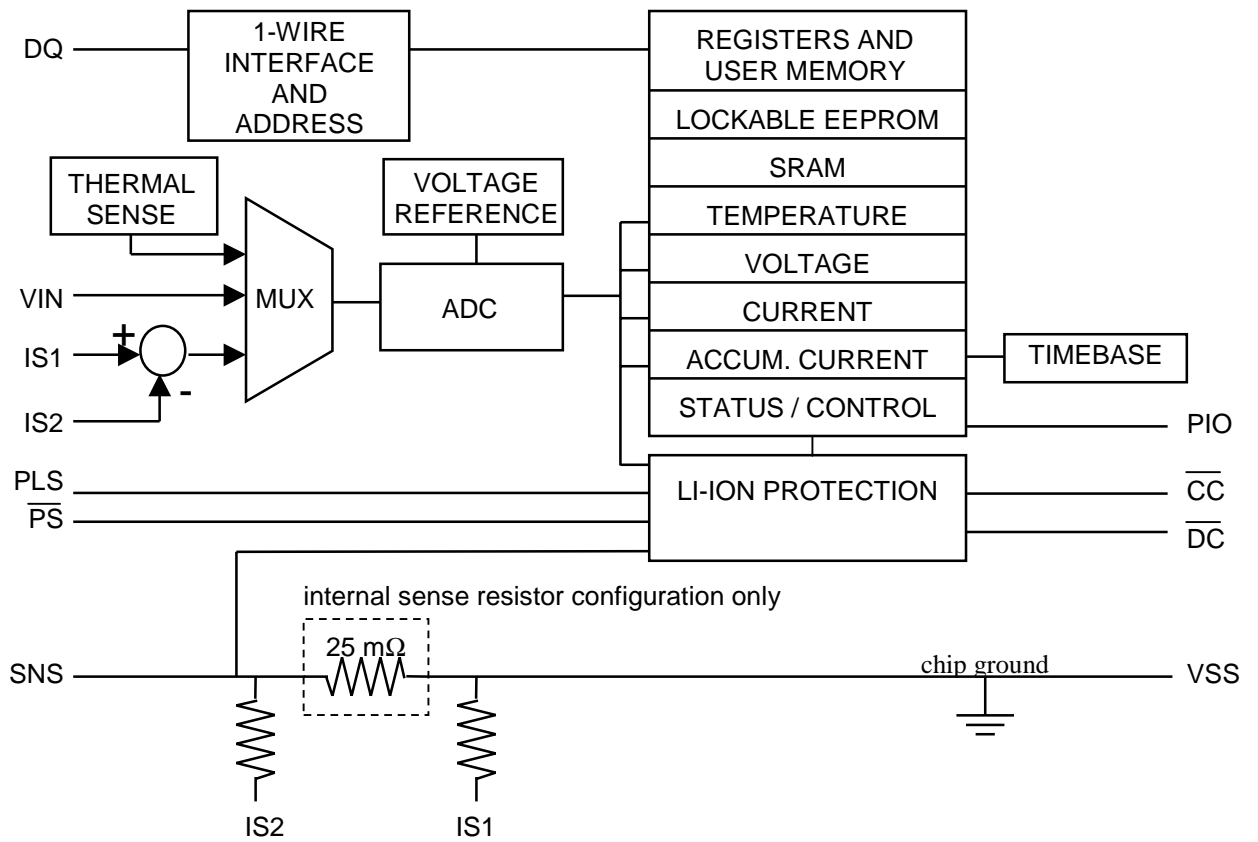

**DETAILED PIN DESCRIPTION – Table 1**

<b>SYMBOL</b>	<b>DESCRIPTION</b>
$\overline{CC}$	<b>Charge Protection Control Output.</b> Controls an external p-channel high-side charge protection FET.
$\overline{DC}$	<b>Discharge Protection Control Output.</b> Controls an external p-channel high-side discharge protection FET.
DQ	<b>Data Input/Out.</b> 1-Wire data line. Open-drain output driver. Connect this pin to the DATA terminal of the battery pack. Pin has an internal 1 $\mu$ A pull-down for sensing disconnection.
PIO	<b>Programmable I/O Pin.</b> Used to control and monitor user-defined external circuitry. Open drain to VSS.
PLS	<b>Battery Pack Positive Terminal Input.</b> The device monitors the state of the battery pack's positive terminal through this pin in order to detect events such as the attachment of a charger or the removal of a short circuit.
$\overline{PS}$	<b>Power Switch Sense Input.</b> The device wakes up from Sleep Mode when it senses the closure of a switch to VSS on this pin. Pin has an internal 1 $\mu$ A pull-up.
VIN	<b>Voltage Sense Input.</b> The voltage of the Li-Ion cell is monitored via this input pin.
VDD	<b>Power Supply Input.</b> Connect to the positive terminal of the Li-Ion cell through a decoupling network.
VSS	<b>Device Ground.</b> Connect directly to the negative terminal of the Li-Ion cell. For the external sense resistor configuration, connect the sense resistor between VSS and SNS.
SNS	<b>Sense Resistor Connection.</b> Connect to the negative terminal of the battery pack. In the internal sense resistor configuration, the sense resistor is connected between VSS and SNS.
IS1	<b>Current Sense Input.</b> This pin is internally connected to VSS through a 4.7 k $\Omega$ resistor. Connect a 0.1 $\mu$ F capacitor between IS1 and IS2 to complete a low-pass input filter.
IS2	<b>Current Sense Input.</b> This pin is internally connected to SNS through a 4.7 k $\Omega$ resistor.

**APPLICATION EXAMPLE – Figure 2**

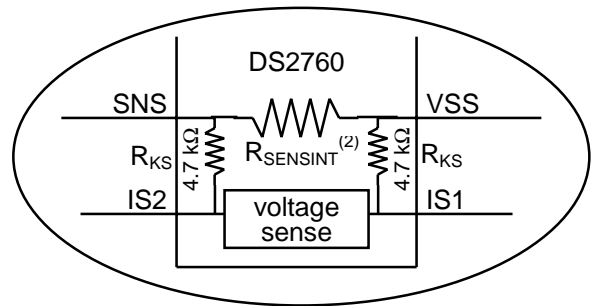
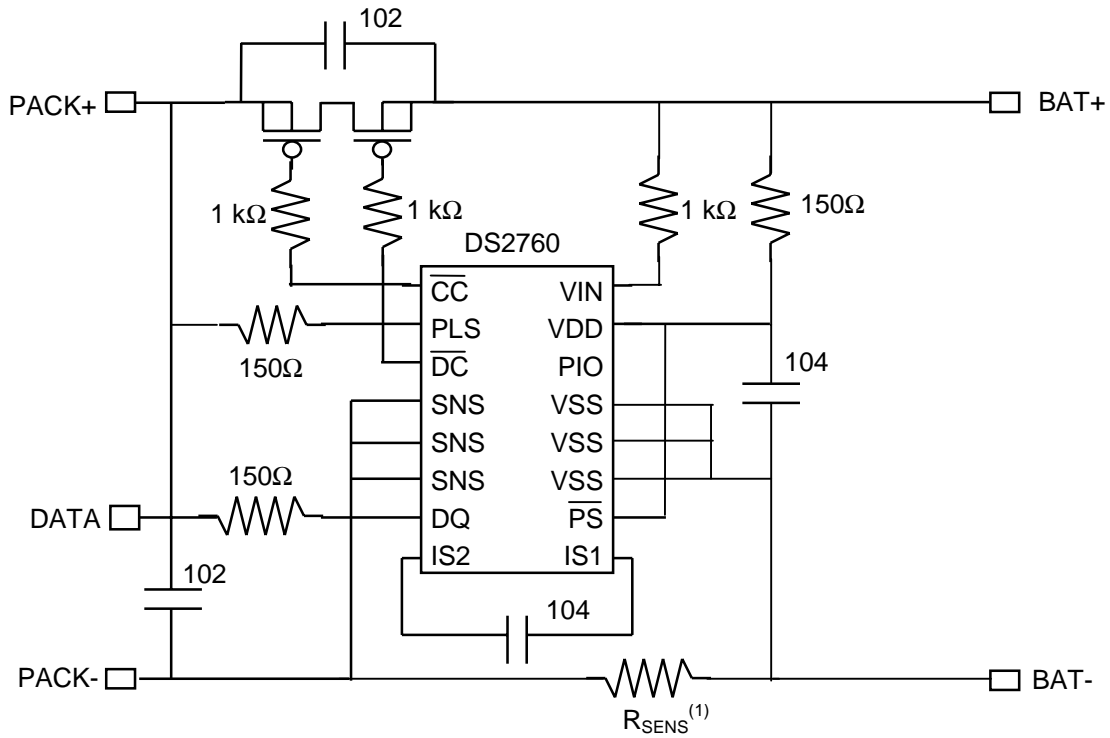

- 1 –  $R_{SENS}$  is present for external sense resistor configurations only
- 2 –  $R_{SENSINT}$  is present for internal sense resistor configurations only

## POWER MODES

The DS2760 has two power modes: Active and Sleep. While in Active Mode, the DS2760 continually measures current, voltage and temperature to provide data to the host system and to support current accumulation and Li-ion safety monitoring. In Sleep Mode, the DS2760 ceases these activities. The DS2760 enters Sleep Mode when either of the following conditions occurs:

- the PMOD bit in the Status Register has been set to 1 and the DQ line is low for longer than 2 seconds (pack disconnection)
- the voltage on VIN drops below undervoltage threshold  $V_{UV}$  for  $t_{UVD}$  (cell depletion)
- the pack is disabled through the issuance of a SWAP command (SWEN bit =1)

The DS2760 returns to Active Mode when any of the following occurs:

- the PMOD bit has been set to 1 and the SWEN bit is set to 0 and the DQ line is pulled high (pack connection)
- the  $\overline{PS}$  pin is pulled low (power switch)
- the voltage on PLS becomes greater than the voltage on VIN (charger connection) with the SWEN bit set to 0
- the pack is enabled through the issuance of a SWAP command (SWEN bit =1)

The DS2760 defaults to Active Mode when power is first applied.

## LI-ION PROTECTION CIRCUITRY

During Active Mode, the DS2760 constantly monitors cell voltage and current to protect the battery from overcharge (overvoltage), overdischarge (undervoltage) and excessive charge and discharge currents (overcurrent, short circuit). Conditions and DS2760 responses are described in the sections below and summarized in Table 2 and Figure 3.

### LI-ION PROTECTION CONDITIONS AND DS2760 RESPONSES – Table 2

Condition Name	Activation			Release Threshold
	Threshold	Delay	Response	
Overvoltage	$V_{IN} > V_{OV}$	$t_{OVD}$	$\overline{CC}$ high	$V_{IN} < V_{CE}$
Undervoltage	$V_{IN} < V_{UV}$	$t_{UVD}$	$\overline{CC}$ , $\overline{DC}$ high, Sleep Mode	$V_{PLS} > VDD$ (charger connected)
Overcurrent, Charge	$V_{IS} > V_{OC}^{(1)}$	$t_{OCD}$	$\overline{CC}$ , $\overline{DC}$ high	$V_{PLS} < VDD - V_{TP}^{(2)}$
Overcurrent, Discharge	$V_{IS} < -V_{OC}^{(1)}$	$t_{OCD}$	$\overline{DC}$ high	$V_{PLS} > VDD - V_{TP}^{(3)}$
Short Circuit	$V_{SNS} > V_{SC}$	$t_{SCD}$	$\overline{DC}$ high	$V_{PLS} > VDD - V_{TP}^{(3)}$

$V_{IS} = V_{IS1} - V_{IS2}$ . Logic high =  $V_{PLS}$  for  $\overline{CC}$  and  $VDD$  for  $\overline{DC}$ . All voltages are with respect to VSS.  $I_{SNS}$  references current delivered from pin SNS.

- (1) for the internal sense resistor configuration, the overcurrent thresholds are expressed in terms of current:  $I_{SNS} > I_{OC}$  for charge direction and  $I_{SNS} < -I_{OC}$  for discharge direction
- (2) with test current  $I_{TST}$  current flowing from PLS to VSS (pull-down on PLS)
- (3) with test current  $I_{TST}$  current flowing from VDD to PLS (pull-up on PLS)

**Overvoltage.** If the voltage of the cell exceeds overvoltage threshold  $V_{OV}$  for a period longer than overvoltage delay  $t_{OVD}$ , the DS2760 shuts off the external charge FET and sets the OV flag in the Protection Register. When the cell voltage falls below charge enable threshold  $V_{CE}$ , the DS2760 turns the charge FET back on (unless another protection condition prevents it). Discharging remains enabled during overvoltage.

**Undervoltage.** If the voltage of the cell drops below undervoltage threshold  $V_{UV}$  for a period longer than undervoltage delay  $t_{UVD}$ , the DS2760 shuts off the charge and discharge FETs, sets the UV flag in the Protection Register, and enters Sleep Mode.

**Overcurrent, Charge Direction.** The voltage difference between the IS1 pin and the IS2 pin ( $V_{IS} = V_{IS1} - V_{IS2}$ ) is the filtered voltage drop across the current sense resistor. If  $V_{IS}$  exceeds overcurrent threshold  $V_{OC}$  for a period longer than overcurrent delay  $t_{OCD}$ , the DS2760 shuts off both external FETs and sets the COC flag in the Protection Register. The charge current path is not re-established until the voltage on the PLS pin drops below  $V_{DD} - V_{TP}$ . The DS2760 provides a test current of value  $I_{TST}$  from PLS to VSS to pull PLS down when the offending charge current source has been removed.

**Overcurrent, Discharge Direction.** If  $V_{IS}$  is less than  $-V_{OC}$  for a period longer than  $t_{OCD}$ , the DS2760 shuts off the external discharge FET and sets the DOC flag in the Protection Register. The discharge current path is not re-established until the voltage on PLS rises above  $V_{DD} - V_{TP}$ . The DS2760 provides a test current of value  $I_{TST}$  from VDD to PLS to pull PLS up when the offending low-impedance load has been removed.

**Short Circuit.** If the voltage on the SNS pin with respect to VSS exceeds short circuit threshold  $V_{SC}$  for a period longer than short circuit delay  $t_{SCD}$ , the DS2760 shuts off the external discharge FET and sets the DOC flag in the Protection Register. The discharge current path is not re-established until the voltage on PLS rises above  $V_{DD} - V_{TP}$ . The DS2760 provides a test current of value  $I_{TST}$  from VDD to PLS to pull PLS up when the short circuit has been removed.

### LITHIUM-ION PROTECTION CIRCUITRY EXAMPLE WAVEFORMS – Figure 3

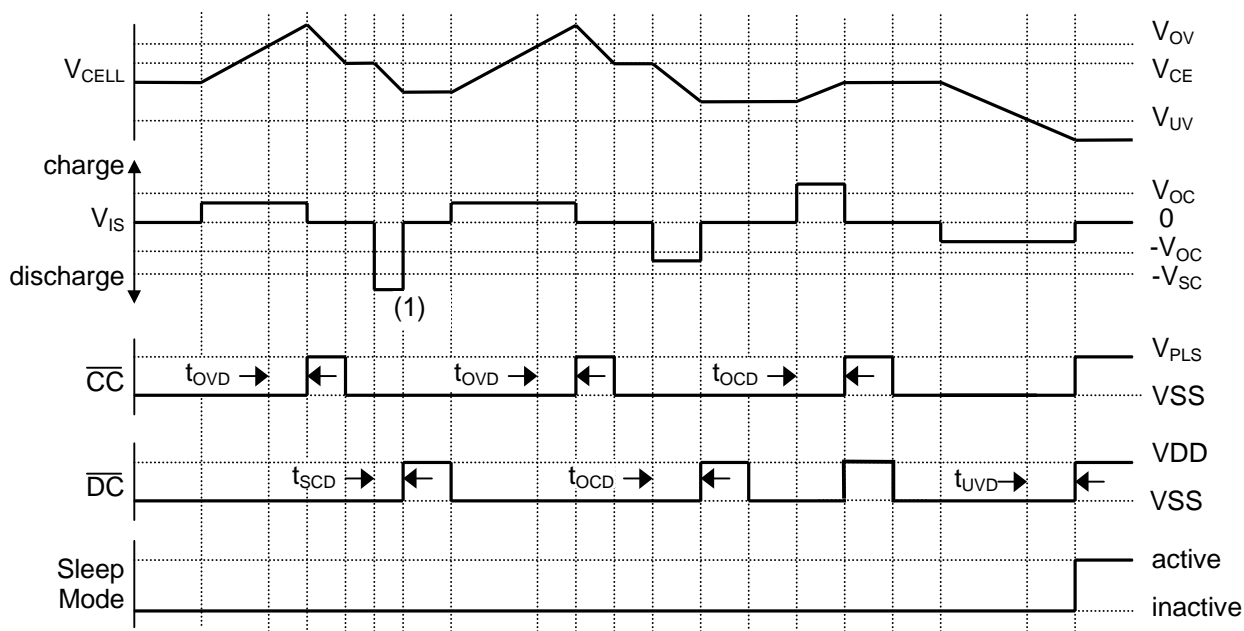

(1) To allow the device to react quickly to short circuits, detection is actually done on the SNS pin rather than on the filtered IS1 and IS2 pins. The actual short circuit detect condition is  $V_{SNS} > V_{SC}$ .

**Summary.** All of the protection conditions described above are OR'ed together to affect the  $\overline{CC}$  and  $\overline{DC}$  outputs.

$\overline{DC}$  = (Undervoltage) or (Overcurrent, EITHER Direction) or (Short Circuit) or (Protection Register bit DE = 0) or (Sleep Mode)

$\overline{CC}$  = (Overvoltage) or (Overcurrent, Charge Direction) or (Protection Register bit CE = 0) or (Sleep Mode)

## CURRENT MEASUREMENT

In the Active Mode of operation, the DS2760 continually measures the current flow into and out of the battery by measuring the voltage drop across a current sense resistor. The DS2760 is available in two configurations: (1) internal 25 m $\Omega$  current sense resistor, and (2) external user-selectable sense resistor. In either configuration, the DS2760 considers the voltage difference between pins IS1 and IS2 ( $V_{IS} = V_{IS1} - V_{IS2}$ ) to be the filtered voltage drop across the sense resistor. A positive  $V_{IS}$  value indicates current is flowing into the battery (charging), while a negative  $V_{IS}$  value indicates current is flowing out of the battery (discharging). Note that when an external sense resistor is used, one end of the resistor must be wired directly to VSS (the negative terminal of the cell) for proper operation of the current measurement circuitry.

$V_{IS}$  is measured with a signed resolution of 12-bits. Measurements are placed in the Current Register in two's-complement format. Currents outside the range of the register are reported at the limit of the range. The format of the Current Register is shown in Figure 4.

For the internal sense resistor configuration, the DS2760 maintains the Current Register in units of Amps, with a resolution of 0.625 mA and full scale range of no less than  $\pm 1.8A$  (see Note 7 on  $I_{FS}$  spec for more details). The DS2760 automatically compensates for internal sense resistor process variations and temperature effects when reporting current.

For the external sense resistor configuration, the DS2760 writes the measured  $V_{IS}$  voltage to the Current Register, with a resolution of 15.625  $\mu V$  and a full scale range of  $\pm 64$  mV.

## CURRENT REGISTER FORMAT – Figure 4

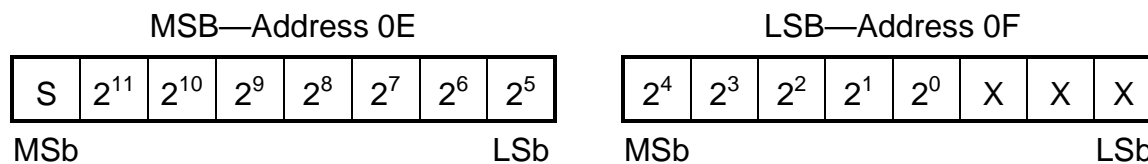

Units: 0.625 mA for internal sense resistor  
15.625  $\mu V$  for external sense resistor

## CURRENT ACCUMULATOR

The Current Accumulator facilitates remaining capacity estimation by tracking the net current flow into and out of the battery. Current flow into the battery increments the Current Accumulator while current flow out of the battery decrements it. Data is maintained in the Current Accumulator in two's-complement format. The format of the Current Accumulator is shown in Figure 5.



When the internal sense resistor is used, the DS2760 maintains the Current Accumulator in units of Amp-hours, with a resolution of 0.25 mAhrs and full scale range of  $\pm 8.2$  Ahrs. When using an external sense resistor, the DS2760 maintains the Current Accumulator in units of Volt-hours, with a resolution of 6.25  $\mu$ Vhrs and a full scale range of  $\pm 205$  mVhrs.

The Current Accumulator is a read/write register that can be altered by the host system as needed.

## CURRENT ACCUMULATOR FORMAT – Figure 5

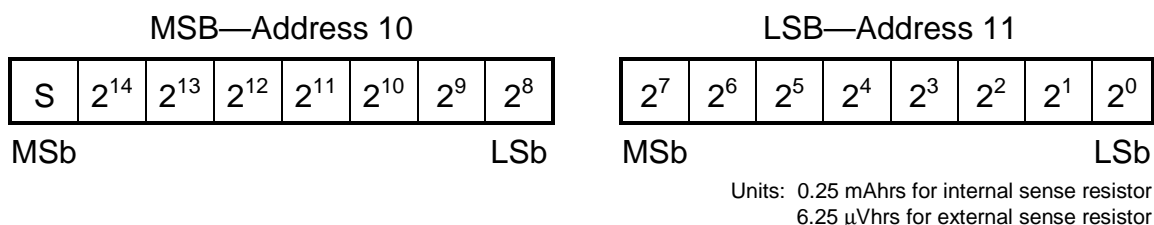

## CURRENT OFFSET COMPENSATION

CURRENT MEASUREMENT and the CURRENT ACCUMULATION are both internally compensated for offset on a continual basis minimizing error resulting from variations in device temperature and voltage. Additionally a constant bias may be utilized to alter any other sources of offset. This bias resides in EEPROM address 33h in two's-complement format and is subtracted from each current measurement.

## CURRENT OFFSET BIAS – Figure 6

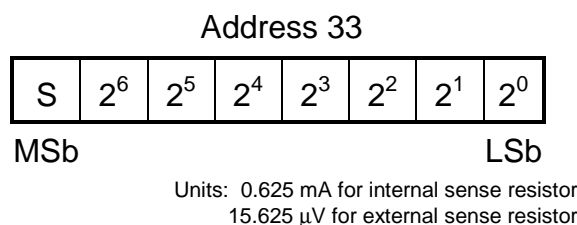

## VOLTAGE MEASUREMENT

The DS2760 continually measures the voltage between pins VIN and VSS over a range of 0 to 5-volts. The resulting data is placed in the Voltage Register in two's-complement format with a resolution of 4.88 mV. Voltages above the maximum register value are reported as the maximum value. The Voltage Register format is shown in Figure 7.

## VOLTAGE REGISTER FORMAT – Figure 7

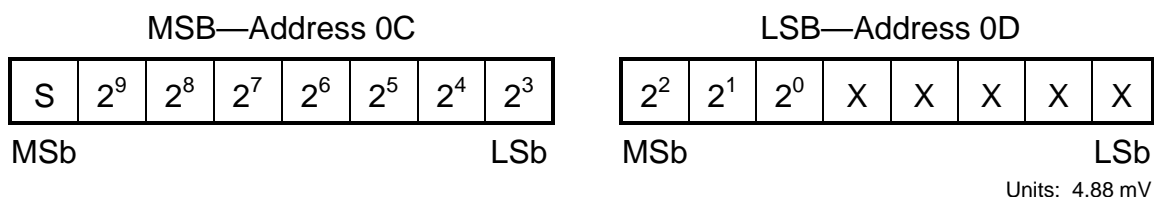

## TEMPERATURE MEASUREMENT

The DS2760 uses an integrated temperature sensor to continually measure battery temperature. Temperature measurements are placed in the Temperature Register in two's-complement format with a resolution of  $0.125^{\circ}\text{C}$  over a range of  $\pm 127^{\circ}\text{C}$ . The Temperature Register format is shown in Figure 8.

### TEMPERATURE REGISTER FORMAT – Figure 8

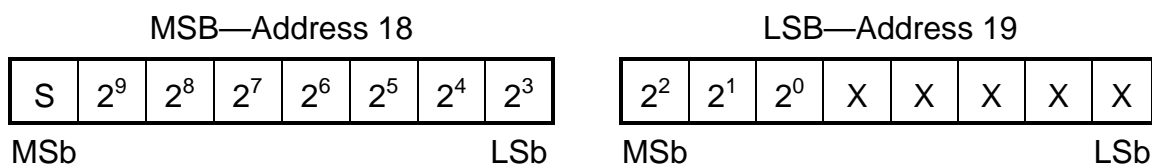

Units:  $0.125^{\circ}\text{C}$

## PROGRAMMABLE I/O

To use the PIO pin as an output, write the desired output value to the PIO bit in the Special Feature Register. Writing a 0 to the PIO bit enables the PIO output driver, pulling the PIO pin to VSS. Writing a 1 to the PIO bit disables the output driver, allowing the PIO pin to be pulled high or used as an input. To sense the value on the PIO pin, read the PIO bit. The DS2760 turns off the PIO output driver when it enters Sleep Mode or when DQ is low for more than 2 seconds, regardless of the state of the PMOD bit.

## POWER SWITCH INPUT

The DS2760 provides a power control function that uses the discharge protection FET to gate battery power to the system. The  $\overline{\text{PS}}$  pin, internally pulled to VDD through a  $1\ \mu\text{A}$  current source, is continuously monitored for a low-impedance connection to VSS. If the DS2760 is in Sleep Mode, the detection of a low on  $\overline{\text{PS}}$  causes the device to transition into Active Mode, turning on the discharge FET. If the DS2760 is already in Active Mode, activity on  $\overline{\text{PS}}$  has no effect other than the mirroring of its logic level in the  $\overline{\text{PS}}$  bit in the Special Feature Register.

## MEMORY

The DS2760 has a 256-byte linear address space with registers for instrumentation, status and control in the lower 32 bytes, with lockable EEPROM and SRAM memory occupying portions of the remaining address space. All EEPROM and SRAM memory is general-purpose except addresses 30h, 31h, and 33h, which should be written with the default values for the Protection Register, Status Register, and Current Offset Register, respectively. When the MSB of any 2 byte register is read, both the MSB and LSB are latched and held for the duration of the Read Data command to prevent updates during the read and ensure synchronization between the two register bytes. For consistent results, always read the MSB and the LSB of a two-byte register during the same Read Data command sequence.

EEPROM memory is shadowed by RAM to eliminate programming delays between writes and to allow the data to be verified by the host system before being copied to EEPROM. All reads and writes to/from EEPROM memory actually access the shadow RAM. In unlocked EEPROM blocks, the Write Data command updates shadow RAM. In locked EEPROM blocks, the Write Data command is ignored. The Copy Data command copies the contents of shadow RAM to EEPROM in an unlocked block of EEPROM but has no effect on locked blocks. The Recall Data command copies the contents of a block of EEPROM to shadow RAM regardless of whether the block is locked or not.

**MEMORY MAP – Table 3**

Address (Hex)	Description	Read/Write
00	Protection Register	R/W
01	Status Register	R
02-06	Reserved	
07	EEPROM Register	R/W
08	Special Feature Register	R/W
09-0B	Reserved	
0C	Voltage Register MSB	R
0D	Voltage Register LSB	R
0E	Current Register MSB	R
0F	Current Register LSB	R
10	Accumulated Current Register MSB	R/W
11	Accumulated Current Register LSB	R/W
12-17	Reserved	
18	Temperature Register MSB	R
19	Temperature Register LSB	R
1A-1F	Reserved	
20-2F	EEPROM, block 0	R/W*
30-3F	EEPROM, block 1	R/W*
40-7F	Reserved	
80-8F	SRAM	R/W
90-FF	Reserved	

Each EEPROM block is read/write until locked by the LOCK command, after which it is read-only.

**PROTECTION REGISTER**

The Protection Register consists of flags that indicate protection circuit status and switches that give conditional control over the charging and discharging paths. Bits OV, UV, COC and DOC are set when corresponding protection conditions occur and remain set until cleared by the host system. The default values of the CE and DE bits of the Protection Register are stored in lockable EEPROM in the corresponding bits in address 30h. A Recall Data command for EEPROM block 1 recalls the default values into CE and DE. The format of the Protection Register is shown in Figure 9. The function of each bit is described in detail in the following paragraphs.

**PROTECTION REGISTER FORMAT Figure – 9**

Address 00							
bit 7	bit 6	bit 5	bit 4	bit 3	bit 2	bit 1	bit 0
OV	UV	COC	DOC	$\overline{CC}$	$\overline{DC}$	CE	DE

**OV** – Overvoltage Flag. When set to 1, this bit indicates the battery pack has experienced an overvoltage condition. This bit must be reset by the host system.

**UV** – Undervoltage Flag. When set to 1, this bit indicates the battery pack has experienced an undervoltage condition. This bit must be reset by the host system.

**COC** – Charge Overcurrent Flag. When set to 1, this bit indicates the battery pack has experienced a charge-direction overcurrent condition. This bit must be reset by the host system.

**DOC** – Discharge Overcurrent Flag. When set to 1, this bit indicates the battery pack has experienced a discharge-direction overcurrent condition. This bit must be reset by the host system.

$\overline{CC}$  –  $\overline{CC}$  Pin Mirror. This read-only bit mirrors the state of the  $\overline{CC}$  output pin.

$\overline{DC}$  –  $\overline{DC}$  Pin Mirror. This read-only bit mirrors the state of the  $\overline{DC}$  output pin.

**CE** – Charge Enable. Writing a 0 to this bit disables charging ( $\overline{CC}$  output high, external charge FET off) regardless of cell or pack conditions. Writing a 1 to this bit enables charging, subject to override by the presence of any protection conditions. The DS2760 automatically sets this bit to 1 when it transitions from Sleep Mode to Active Mode.

**DE** – Discharge Enable. Writing a 0 to this bit disables discharging ( $\overline{DC}$  output high, external discharge FET off) regardless of cell or pack conditions. Writing a 1 to this bit enables discharging, subject to override by the presence of any protection conditions. The DS2760 automatically sets this bit to 1 when it transitions from Sleep Mode to Active Mode.

## STATUS REGISTER

The default values for the Status Register bits are stored in lockable EEPROM in the corresponding bits of address 31h. A Recall Data command for EEPROM block 1 recalls the default values into the Status Register bits. The format of the Status Register is shown in Figure 10. The function of each bit is described in detail in the following paragraphs.

### STATUS REGISTER FORMAT – Figure 10

Address 01							
bit 7	bit 6	bit 5	bit 4	bit 3	bit 2	bit 1	bit 0
X	X	PMOD	RNAOP	SWEN	X	X	X

**PMOD** – Sleep Mode Enable. A value of 1 in this bit enables the DS2760 to enter Sleep Mode when the DQ line goes low for greater than 2 seconds and leave Sleep Mode when the DQ line goes high. A value of 0 disables DQ-related transitions into and out of Sleep Mode. This bit is read-only. The desired default value should be set in bit 5 of address 31h.

**RNAOP** – Read Net Address Opcode. A value of 0 in this bit sets the opcode for the Read Net Address command to 33h, while a 1 sets the opcode to 39h. This bit is read-only. The desired default value should be set in bit 4 of address 31h.

**SWEN** - SWAP Command Enable. A value of 1 in this bit location enables the recognition of a SWAP command. If set to 0, SWAP commands are ignored. The desired default value should be set in bit 3 of address 31h. This bit is read-only.

**X** – Reserved bits.

## EEPROM REGISTER

The format of the EEPROM Register is shown in Figure 11. The function of each bit is described in detail in the following paragraphs.

### EEPROM REGISTER FORMAT Figure – 11

Address 07							
bit 7	bit 6	bit 5	bit 4	bit 3	bit 2	bit 1	bit 0
EEC	LOCK	X	X	X	X	BL1	BL0

**EEC** – EEPROM Copy Flag. A 1 in this read-only bit indicates that a Copy Data command is in progress. While this bit is high, writes to EEPROM addresses are ignored. A 0 in this bit indicates that data may be written to unlocked EEPROM blocks.

**LOCK** – EEPROM Lock Enable. When this bit is 0, the Lock command is ignored. Writing a 1 to this bit enables the Lock command. After the Lock command is executed, the LOCK bit is reset to 0.

**BL1** – EEPROM Block 1 Lock Flag. A 1 in this read-only bit indicates that EEPROM Block 1 (addresses 30-3F) is locked (read-only) while a 0 indicates Block 1 is unlocked (read/write).

**BL0** – EEPROM Block 0 Lock Flag. A 1 in this read-only bit indicates that EEPROM Block 0 (addresses 20-2F) is locked (read-only) while a 0 indicates Block 0 is unlocked (read/write).

**X** – Reserved bits.

## SPECIAL FEATURE REGISTER

The format of the Special Feature Register is shown in Figure 12. The function of each bit is described in detail in the following paragraphs.

### SPECIAL FEATURE REGISTER FORMAT Figure – 12

Address 08							
bit 7	bit 6	bit 5	bit 4	bit 3	bit 2	bit 1	bit 0
$\overline{\text{PS}}$	PIO	MSTR	X	X	X	X	X

$\overline{\text{PS}}$  –  $\overline{\text{PS}}$  Pin Mirror. This read-only bit mirrors the state of the  $\overline{\text{PS}}$  pin.

**PIO** – PIO Pin Sense and Control. See the Programmable I/O section for details on this read/write bit.

**MSTR** - SWAP Master status bit. This bit indicates whether a device has been selected through the SWAP command. Selection of this device through the SWAP command and the appropriate Net Address will result in setting this bit, indicating that this device is the master. A 0 signifies that this device is not the master.

**X** – Reserved bits.

## 1-WIRE BUS SYSTEM

The 1-Wire bus is a system which has a single bus master and one or more slaves. A multi-drop bus is a 1-Wire bus with multiple slaves. A single-drop bus has only one slave device. In all instances, the DS2760 is a slave device. The bus master is typically a microprocessor in the host system. The discussion of this bus system consists of four topics: 64-Bit Net Address, Hardware Configuration, Transaction Sequence, and 1-Wire Signaling.

## 64-BIT NET ADDRESS

Each DS2760 has a unique, factory-programmed 1-Wire net address which is 64 bits in length. The first 8 bits are the 1-Wire family code (30h for DS2760). The next 48 bits are a unique serial number. The last 8 bits are a CRC of the first 56 bits (see Figure 13). The 64-bit net address and the 1-Wire I/O circuitry built into the device enable the DS2760 to communicate via the 1-Wire protocol detailed in the 1-Wire Bus System section of this datasheet.

### 1-WIRE NET ADDRESS FORMAT – Figure 13

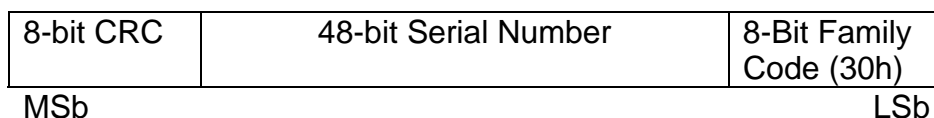

## CRC GENERATION

The DS2760 has an 8-bit CRC stored in the most significant byte of its 1-Wire net address. To ensure error-free transmission of the address, the host system can compute a CRC value from the first 56 bits of the address and compare it to the CRC from the DS2760. The host system is responsible for verifying the CRC value and taking action as a result. The DS2760 does not compare CRC values and does not prevent a command sequence from proceeding as a result of a CRC mismatch. Proper use of the CRC can result in a communication channel with a very high level of integrity.

The CRC can be generated by the host using a circuit consisting of a shift register and XOR gates as shown in Figure 10, or it can be generated in software. Additional information about the Dallas 1-Wire Cyclic Redundancy Check is available in Application Note 27 entitled “Understanding and Using Cyclic Redundancy Checks with Dallas Semiconductor Touch Memory Products”.

In the circuit in Figure 14, the shift register bits are initialized to 0. Then, starting with the least significant bit of the family code, one bit at a time is shifted in. After the 8<sup>th</sup> bit of the family code has been entered, then the serial number is entered. After the 48<sup>th</sup> bit of the serial number has been entered, the shift register contains the CRC value.

## 1-WIRE CRC GENERATION BLOCK DIAGRAM – Figure 14

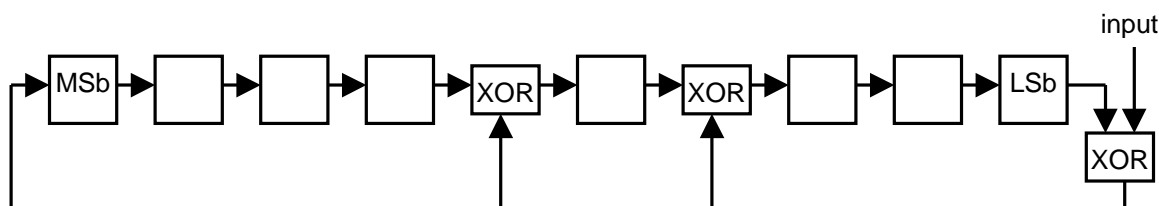

### HARDWARE CONFIGURATION

Because the 1-Wire bus has only a single line, it is important that each device on the bus be able to drive it at the appropriate time. To facilitate this, each device attached to the 1-Wire bus must connect to the bus with open-drain or tri-state output drivers. The DS2760 used an open-drain output driver as part of the bi-directional interface circuitry shown in Figure 15. If a bi-directional pin is not available on the bus master, separate output and input pins can be tied together.

The 1-Wire bus must have a pull-up resistor at the bus-master end of the bus. For short line lengths, the value of this resistor should be approximately 5 k $\Omega$ . The idle state for the 1-Wire bus is high. If, for any reason, a bus transaction must be suspended, the bus **MUST** be left in the idle state in order to properly resume the transaction later. If the bus is left low for more than 120  $\mu$ s, slave devices on the bus begin to interpret the low period as a Reset Pulse, effectively terminating the transaction.

### 1-WIRE BUS INTERFACE CIRCUITRY – Figure 15

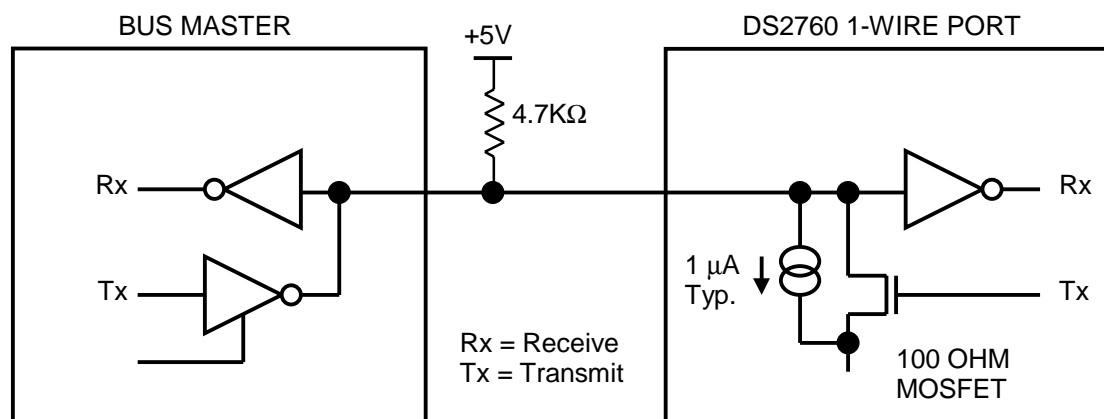

### TRANSACTION SEQUENCE

The protocol for accessing the DS2760 via the 1-Wire port is as follows:

- Initialization
- Net Address Command
- Function Command
- Transaction/Data

The sections that follow describe each of these steps in detail.

All transactions of the 1-Wire bus begin with an initialization sequence consisting of a Reset Pulse transmitted by the bus master followed by a presence pulse simultaneously transmitted by the DS2760 and any other slaves on the bus. The presence pulse tells the bus master that one or more devices are on the bus and ready to operate. For more details, see the 1-Wire Signaling section.

## NET ADDRESS COMMANDS

Once the bus master has detected the presence of one or more slaves, it can issue one of the Net Address Commands described in the following paragraphs. The name of each ROM Command is followed by the 8-bit opcode for that command in square brackets. Figure 16 presents a transaction flowchart of the Net Address Commands.

**Read Net Address [33h or 39h].** This command allows the bus master to read the DS2760's 1-Wire net address. This command can only be used if there is a single slave on the bus. If more than one slave is present, a data collision occurs when all slaves try to transmit at the same time (open drain produces a wired-AND result). The RNAOP bit in the Status Register selects the opcode for this command, with RNAOP=0 indicating 33h and RNAOP=1 indicating 39h.

**Match Net Address [55h].** This command allows the bus master to specifically address one DS2760 on the 1-Wire bus. Only the addressed DS2760 responds to any subsequent Function Command. All other slave devices ignore the Function Command and wait for a reset pulse. This command can be used with one or more slave devices on the bus.

**Skip Net Address [CCh].** This command saves time when there is only one DS2760 on the bus by allowing the bus master to issue a Function Command without specifying the address of the slave. If more than one slave device is present on the bus, a subsequent Function Command can cause a data collision when all slaves transmit data at the same time.

**Search Net Address [F0h].** This command allows the bus master to use a process of elimination to identify the 1-Wire net addresses of all slave devices on the bus. The search process involves the repetition of a simple three-step routine: read a bit, read the complement of the bit, then write the desired value of that bit. The bus master performs this simple three-step routine on each bit location of the net address. After one complete pass through all 64 bits, the bus master knows the address of one device. The remaining devices can then be identified on additional iterations of the process. See Chapter 5 of the Book of DS19xx iButton™ Standards for a comprehensive discussion of a net address search, including an actual example.

**SWAP [AAh].** SWAP is a Net Address level command specifically intended to aid in distributed multiplexing applications and is described specifically with regards to power control using the 27xx series of products. The term power control refers to the ability of the DS2760 to control the flow of power into or out the battery pack using control pins  $\overline{DC}$  and  $\overline{CC}$ . The SWAP command is issued followed by the Net Address. The effect is to cause the addressed device to enable power to or from the system while simultaneously (break-before-make) deselecting and powering down (SLEEP) all other packs. This switching sequence is controlled by a timing pulse issued on the DQ line following the Net Address. The falling edge of the pulse is used to disable power with the rising edge enabling power flow by the selected device. The DS2760 will recognize a SWAP command, device address and, timing pulse if and only if the SWEN bit is set.



---

## FUNCTION COMMANDS

After successfully completing one of the Net Address Commands, the bus master can access the features of the DS2760 with any of the Function Commands described in the following paragraphs. The name of each function is followed by the 8-bit opcode for that command in square brackets.

**Read Data [69h, XX].** This command reads data from the DS2760 starting at memory address XX. The LSB of the data in address XX is available to be read immediately after the MSb of the address has been entered. Because the address is automatically incremented after the MSb of each byte is received, the LSB of the data at address XX+1 is available to be read immediately after the MSb of the data at address XX. If the bus master continues to read beyond address FFh, the DS2760 outputs logic 1 until a Reset Pulse occurs. Addresses labeled “Reserved” in the Memory Map contain undefined data. The Read Data command may be terminated by the bus master with a Reset Pulse at any bit boundary.

**Write Data [6Ch, XX].** This command writes data to the DS2760 starting at memory address XX. The LSB of the data to be stored at address XX can be written immediately after the MSb of address has been entered. Because the address is automatically incremented after the MSb of each byte is written, the LSB to be stored at address XX+1 can be written immediately after the MSb to be stored at address XX. If the bus master continues to write beyond address FFh, the DS2760 ignores the data. Writes to read-only addresses, reserved addresses and locked EEPROM blocks are ignored. Incomplete bytes are not written. Writes to unlocked EEPROM blocks are to shadow RAM rather than EEPROM. See the Memory section for more details.

**Copy Data [48h, XX].** This command copies the contents of shadow RAM to EEPROM for the 16-byte EEPROM block containing address XX. Copy Data commands that address locked blocks are ignored. While the Copy Data command is executing, the EEC bit in the EEPROM Register is set to 1 and writes to EEPROM addresses are ignored. Reads and writes to non-EEPROM addresses can still occur while the copy is in progress. The Copy Data command takes  $t_{EEC}$  time to execute, starting on the next falling edge after the address is transmitted.

**Recall Data [B8h, XX].** This command recalls the contents of the 16-byte EEPROM block containing address XX to shadow RAM.

**Lock [6Ah, XX].** This command locks (write-protects) the 16-byte block of EEPROM memory containing memory address XX. The LOCK bit in the EEPROM Register must be set to 1 before the Lock command is executed. If the LOCK bit is 0, the Lock command has no effect. The Lock command is permanent; a locked block can never be written again.

**FUNCTION COMMANDS – Table 4**

<b>Command</b>	<b>Description</b>	<b>Command Protocol</b>	<b>Bus State After Command Protocol</b>	<b>Bus Data</b>
Read Data	Reads data from memory starting at address XX	69h, XX	Master Rx	up to 256 bytes of data
Write Data	Writes data to memory starting at address XX	6Ch, XX	Master Tx	up to 256 bytes of data
Copy Data	Copies shadow RAM data to EEPROM block containing address XX	48h, XX	Master Reset	none
Recall Data	Recalls EEPROM block containing address XX to shadow RAM	B8h, XX	Master Reset	none
Lock	Permanently locks the block of EEPROM containing address XX	6Ah, XX	Master Reset	none



## I/O SIGNALING

The 1-Wire bus requires strict signaling protocols to insure data integrity. The four protocols used by the DS2760 are: the initialization sequence (Reset Pulse followed by Presence Pulse), Write 0, Write 1, and Read Data. All of these types of signaling except the Presence Pulse are initiated by the bus master.

The initialization sequence required to begin any communication with the DS2760 is shown in Figure 17. A Presence Pulse following a Reset Pulse indicates the DS2760 is ready to accept a Net Address Command. The bus master transmits (Tx) a Reset Pulse for  $t_{RSTL}$ . The bus master then releases the line and goes into receive mode (Rx). The 1-Wire bus line is then pulled high by the pull-up resistor. After detecting the rising edge on the DQ pin, the DS2760 waits for  $t_{PDH}$  and then transmits the Presence Pulse for  $t_{PDL}$ .

### 1-WIRE INITIALIZATION SEQUENCE – Figure 17

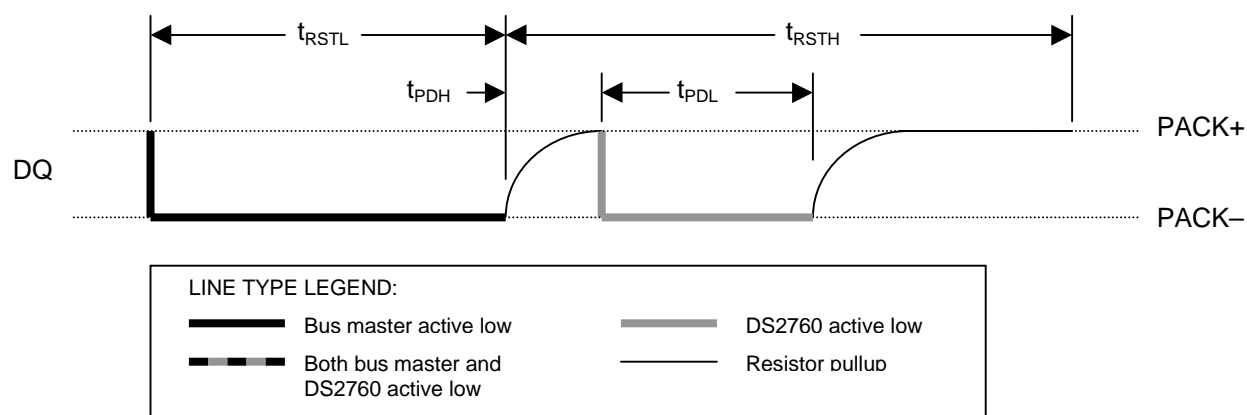

## WRITE TIME SLOTS

A write time slot is initiated when the bus master pulls the 1-Wire bus from a logic high (inactive) level to a logic low level. There are two types of write time slots: Write 1 and Write 0. All write time slots must be  $t_{SLOT}$  (60 to 120  $\mu$ s) in duration with a 1  $\mu$ s minimum recovery time,  $t_{REC}$ , between cycles. The DS2760 samples the 1-Wire bus line between 15 and 60  $\mu$ s after the line falls. If the line is high when sampled, a Write 1 occurs. If the line is low when sampled, a Write 0 occurs (see Figure 18). For the bus master to generate a Write 1 time slot, the bus line must be pulled low and then released, allowing the line to be pulled high within 15  $\mu$ s after the start of the write time slot. For the host to generate a Write 0 time slot, the bus line must be pulled low and held low for the duration of the write time slot.

## READ TIME SLOTS

A read time slot is initiated when the bus master pulls the 1-Wire bus line from a logic high level to a logic low level. The bus master must keep the bus line low for at least 1  $\mu$ s and then release it to allow the DS2760 to present valid data. The bus master can then sample the data  $t_{RDV}$  (15  $\mu$ s) from the start of the read time slot. By the end of the read time slot, the DS2760 releases the bus line and allows it to be pulled high by the external pull-up resistor. All read time slots must be  $t_{SLOT}$  (60 to 120  $\mu$ s) in duration with a 1  $\mu$ s minimum recovery time,  $t_{REC}$ , between cycles. See Figure 18 for more information.

# 1-WIRE WRITE AND READ TIME SLOTS – Figure 18

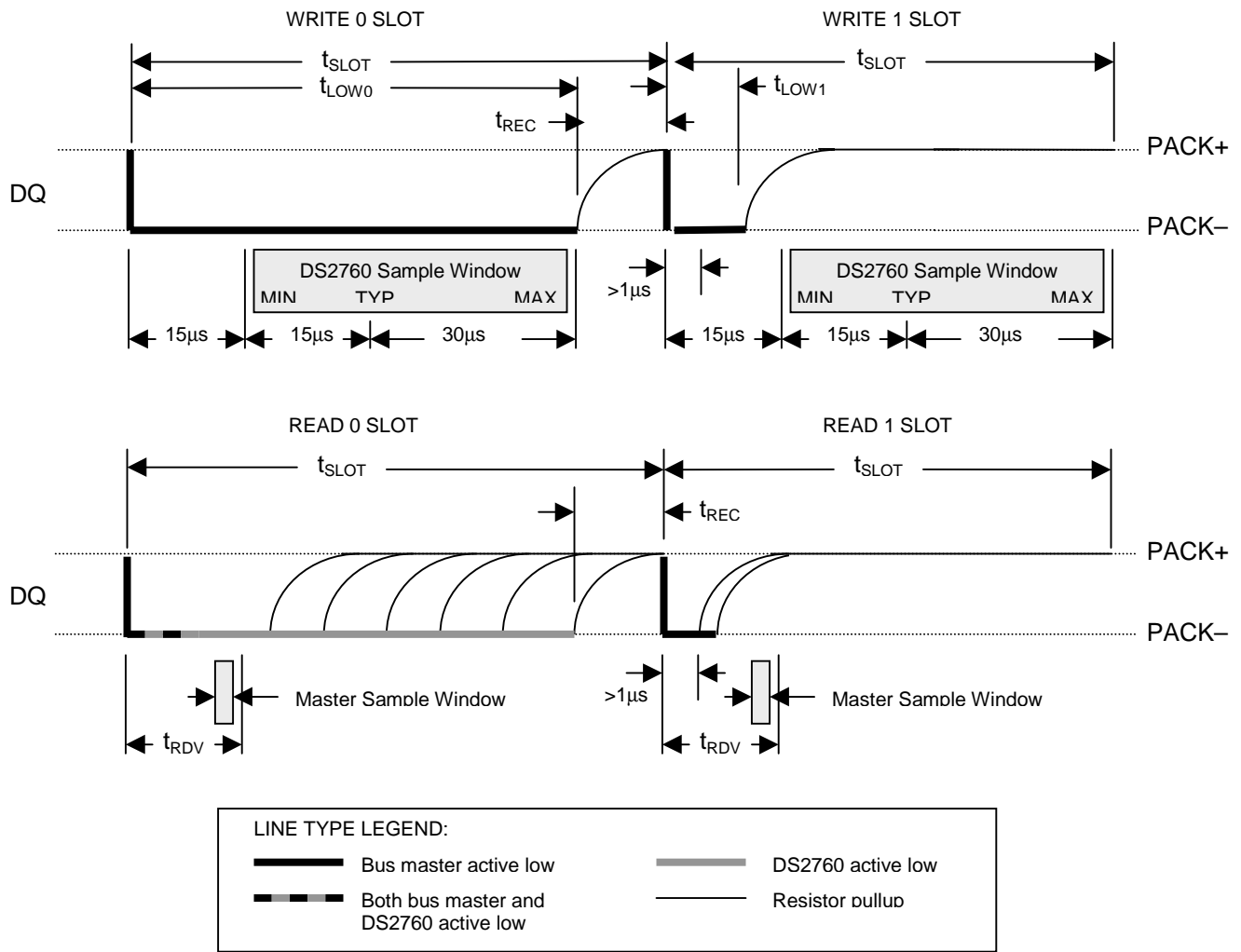

# SWAP COMMAND TIMING – Figure 19

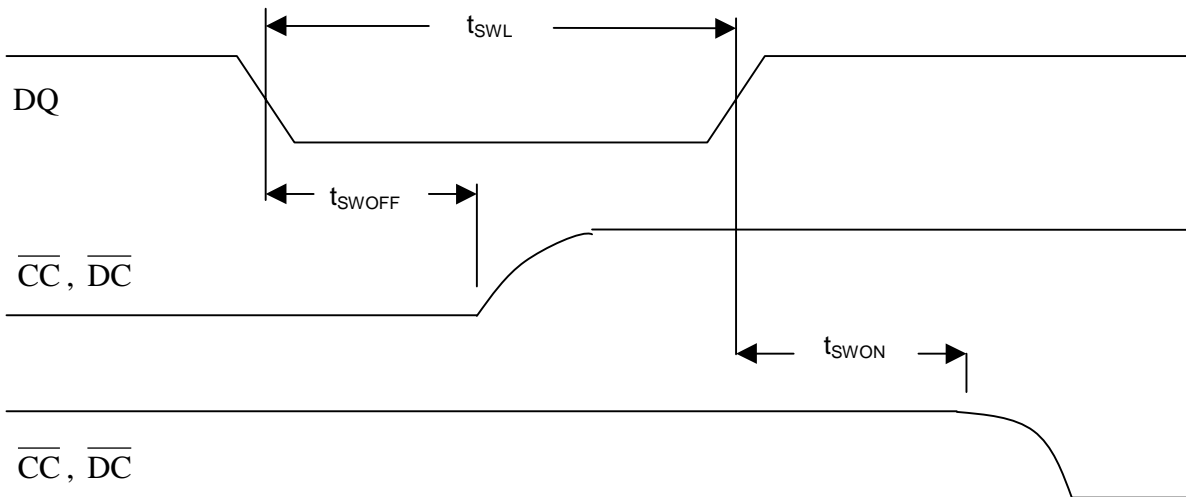

**ABSOLUTE MAXIMUM RATINGS\***

Voltage on PLS and $\overline{CC}$ pin, Relative to VSS	-0.3V to +18V
Voltage on PIO pin, Relative to VSS	-0.3V to +12V
Voltage on any other pin, Relative to VSS	-0.3V to +6V
Continuous Internal Sense Resistor Current	$\pm 2.5A$
Pulsed Internal Sense Resistor Current	$\pm 50A$ for $<100 \mu s/sec$ , $<1000$ pulses
Operating Temperature	$-40^{\circ}C$ to $+85^{\circ}C$
Storage Temperature	$-55^{\circ}C$ to $+125^{\circ}C$
Soldering Temperature	See J-STD-020A Specification

\* This is a stress rating only and functional operation of the device at these or any other conditions above those indicated in the operation sections of this specification is not implied. Exposure to absolute maximum rating conditions for extended periods of time may affect reliability.

**RECOMMENDED DC****OPERATING CONDITIONS**

(-20°C to 70°C, 2.5V ≤ VDD ≤ 5.5V)

PARAMETER	SYMBOL	CONDITION	MIN	TYP	MAX	UNITS	NOTES
Supply Voltage	VDD		2.5		5.5	V	1
Data Pin	DQ		-0.3		5.5	V	1

**DC ELECTRICAL CHARACTERISTICS**

(-20°C to 70°C; 2.5V ≤ VDD ≤ 5.5V)

PARAMETER	SYMBOL	CONDITION	MIN	TYP	MAX	UNITS	NOTES
Active Current	I <sub>ACTIVE</sub>	DQ=VDD, norm. operation		50	80	μA	
Sleep Mode Current	I <sub>SLEEP</sub>	DQ=0V, no activity, $\overline{PS}$ floating		1	2	μA	
Input Logic High: DQ, PIO	V <sub>IH</sub>		1.5			V	1
Input Logic High: $\overline{PS}$	V <sub>IH</sub>		V <sub>DD</sub> -0.2V			V	1
Input Logic Low: DQ, PIO	V <sub>IL</sub>				0.4	V	1
Input Logic Low: $\overline{PS}$	V <sub>IL</sub>				0.2	V	1
Output Logic High: $\overline{CC}$	V <sub>OH</sub>	I <sub>OH</sub> =-0.1 mA	V <sub>PLS</sub> -0.4V			V	1
Output Logic High: $\overline{DC}$	V <sub>OH</sub>	I <sub>OH</sub> =-0.1 mA	VDD-0.4V			V	1
Output Logic Low: $\overline{CC}$ , $\overline{DC}$	V <sub>OL</sub>	I <sub>OL</sub> =0.1 mA			0.4	V	1
Output Logic Low: DQ, PIO	V <sub>OL</sub>	I <sub>OL</sub> =4 mA			0.4	V	1
Input Resistance: DQ	R <sub>IN</sub>			500		kΩ	
Input Resistance: VIN	R <sub>IN</sub>		5			MΩ	
Internal Current Sense Resistor	R <sub>SNS</sub>	25°C	20	25	30	mΩ	
Internal Current Sense Resistor TC	TC <sub>SNS</sub>			4000		ppm/°C	
Internal Kelvin Sense Resistance	R <sub>KS</sub>	IS1 to VSS IS2 to SNS		4.7		kΩ	
DQ Low to Sleep time	t <sub>SLEEP</sub>			2		sec	

**ELECTRICAL CHARACTERISTICS:  
PROTECTION CIRCUITRY**

(-20°C to 70°C; 2.5V ≤ VDD ≤ 5.5V)

PARAMETER	SYMBOL	MIN	TYP	MAX	UNITS	NOTES
Overvoltage Detect	V <sub>OV</sub>	4.300 4.225	4.350 4.275	4.400 4.325	V	1,2
Charge Enable	V <sub>CE</sub>	4.05	4.15	4.25	V	1
Undervoltage Detect	V <sub>UV</sub>	2.5	2.6	2.7	V	1
Overcurrent Detect	I <sub>OC</sub>	1.8	1.9	2.0	A	3
Overcurrent Detect	V <sub>OC</sub>	45	47.5	50	mV	1,4
Short Circuit Detect	V <sub>SC</sub>	100	150	200	mV	1
Overvoltage Delay	t <sub>OVD</sub>	0.8	1	1.2	sec	
Undervoltage Delay	t <sub>UVD</sub>	90	100	110	ms	
Overcurrent Delay	t <sub> OCD</sub>	5	10	20	ms	
Short Circuit Delay	t <sub>SCD</sub>	80	100	120	μs	
Test Threshold	V <sub>TP</sub>	0.5	1.0	1.5	V	
Test Current	I <sub>TST</sub>	10	20	40	μA	

**ELECTRICAL CHARACTERISTICS:****TEMPERATURE, VOLTAGE, CURRENT** (-20°C to 70°C; 2.5V ≤ VDD ≤ 5.5V)

PARAMETER	SYMBOL	MIN	TYP	MAX	UNITS	NOTES
Temperature Resolution	T <sub>LSB</sub>		0.125		°C	
Temperature Full Scale Magnitude	T <sub>FS</sub>	127			°C	
Temperature Error	T <sub>ERR</sub>			±3	°C	5
Voltage Resolution	V <sub>LSB</sub>		4.88		mV	
Voltage Full Scale Magnitude	V <sub>FS</sub>	5			V	
Voltage Offset Error	V <sub>OEERR</sub>			1	LSB	6
Voltage Gain Error	V <sub>GEERR</sub>			5	%V reading	
Current Resolution	I <sub>LSB</sub>		0.625 15.625		mA μV	3 4
Current Full Scale Magnitude	I <sub>FS</sub>	1.8	2.56 64		A mV	3, 4 7
Current Offset Error	I <sub>OEERR</sub>			1	LSB	8
Current Gain Error	I <sub>GEERR</sub>			1	%I reading	9
Accumulated Current Resolution	q <sub>CA</sub>		0.25 6.25		mAh μVhr	3 4
Current Sampling Frequency	f <sub>SAMP</sub>		1456		Hz	
Internal Timebase Accuracy	t <sub>ERR</sub>		±1	±3	%	10

**ELECTRICAL CHARACTERISTICS:****COPY TO EEPROM** (-20°C to 70°C; 2.5V ≤ VDD ≤ 5.5V)

PARAMETER	SYMBOL	MIN	TYP	MAX	UNITS	NOTES
Copy to EEPROM Time	t <sub>EEC</sub>		2	10	ms	
EEPROM Copy Endurance	N <sub>EEC</sub>		25000		cycles	11



**ELECTRICAL CHARACTERISTICS:****1-WIRE INTERFACE**

(-20°C to 70°C; 2.5V ≤ VDD ≤ 5.5V)

PARAMETER	SYMBOL	MIN	TYP	MAX	UNITS	NOTES
Time Slot	t <sub>SLOT</sub>	60		120	μs	
Recovery Time	t <sub>REC</sub>	1			μs	
Write 0 Low Time	t <sub>LOW0</sub>	60		120	μs	
Write 1 Low Time	t <sub>LOW1</sub>	1		15	μs	
Read Data Valid	t <sub>RDV</sub>			15	μs	
Reset Time High	t <sub>RSTH</sub>	480			μs	
Reset Time Low	t <sub>RSTL</sub>	480		960	μs	
Presence Detect High	t <sub>PDH</sub>	15		60	μs	
Presence Detect Low	t <sub>PDL</sub>	60		240	μs	
SWAP timing pulse width	t <sub>SWL</sub>	0.2		480	μs	
SWAP timing pulse falling edge to $\overline{DC}$ release	t <sub>SWOFF</sub>	0		1	μs	12
SWAP timing pulse rising edge to $\overline{DC}$ engage	t <sub>SWON</sub>	0		1	μs	12
DQ Capacitance	C <sub>DQ</sub>			25	pF	

**NOTES**

- All voltages are referenced to VSS.
- See “Ordering Information” section of datasheet to determine corresponding part number for each V<sub>OV</sub> value.
- Internal current sense resistor configuration.
- External current sense resistor configuration.
- Self heating due to output pin loading and sense resistor power dissipation can alter the reading from ambient conditions.
- Voltage offset measurement is with respect to V<sub>OV</sub> at 25°C.
- Although the Current Register is large enough to report values higher than 1.8A, internal compensation for sense resistor process variation and temperature effects can reduce the maximum reportable current to as low as 1.8A.
- Requires in-system calibration by user.
- This spec excludes the effects of temperature on the sense resistor. The DS2760 compensates for the internal sense resistor’s temperature coefficient of 4000 ppm/°C to an accuracy of ±500 ppm/°C. The DS2760 does not attempt to compensate for the characteristics of an external sense resistor. Error terms arising from the use of an external sense resistor should be taken into account when calculating total current measurement error.
- Typical value for t<sub>ERR</sub> is at 3.6V and 25°C.
- 4 year data retention at 70°C.
- Typical load capacitance on  $\overline{DC}$  and  $\overline{CC}$  is 100 pF.