



DVR1V8W - DVR5V0W

COMPLEX ARRAY FOR VOLTAGE REGULATORS

NEW PRODUCT

Features

- Epitaxial Planar Die Construction
- Selectively Paired NPN Transistors & Zener Diodes for Series Pass Voltage Regulator Circuits
- Ideally Suited for Automated Assembly Processes
- **Lead Free By Design/RoHS Compliant (Note 1)**
- **"Green" Device (Note 2)**

Mechanical Data

- Case: SOT-363
- Case Material: Molded Plastic. "Green" Molding Compound. UL Flammability Classification Rating 94V-0
- Moisture Sensitivity: Level 1 per J-STD-020C
- Terminals: Finish – Matte Tin annealed over Alloy 42 leadframe. Solderable per MIL-STD-202, Method 208
- Terminal Connections: See Diagram
- Marking & Type Code Information: See Last Page
- Ordering Information: See Last Page
- Weight: 0.008 grams (approximate)

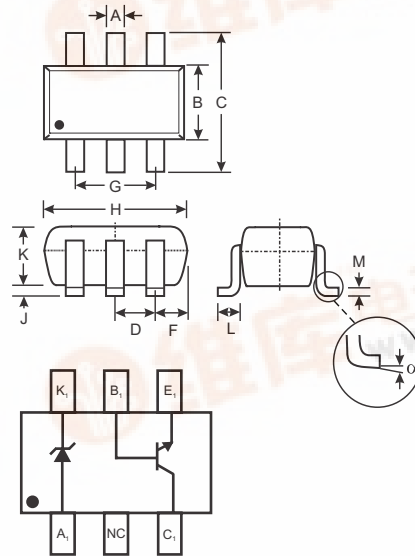

SOT-363		
Dim	Min	Max
A	0.10	0.30
B	1.15	1.35
C	2.00	2.20
D	0.65 Nominal	
F	0.30	0.40
H	1.80	2.20
J	—	0.10
K	0.90	1.00
L	0.25	0.40
M	0.10	0.25
α	8°	
All Dimensions in mm		

Maximum Ratings, Total Device @ $T_A = 25^\circ\text{C}$ unless otherwise specified

Characteristic	Symbol	Value	Unit
Power Dissipation (Note 3)	P_d	200	mW
Thermal Resistance, Junction to Ambient (Note 3)	$R_{\theta JA}$	625	$^\circ\text{C/W}$
Operating and Storage and Temperature Range	T_j, T_{STG}	-55 to +150	$^\circ\text{C}$

Maximum Ratings, NPN Transistor @ $T_A = 25^\circ\text{C}$ unless otherwise specified

Characteristic	Symbol	Value	Unit
Collector-Base Voltage	V_{CBO}	45	V
Collector-Emitter Voltage	V_{CEO}	18	V
Emitter-Base Voltage	V_{EBO}	5	V
Collector Current - Continuous (Note 3)	I_C	1	A

Maximum Ratings, Zener Element @ $T_A = 25^\circ\text{C}$ unless otherwise specified

Characteristic	Symbol	Value	Unit
Forward Voltage @ $I_F = 10\text{mA}$	V_F	0.9	V

- Notes:
1. No purposefully added lead.
 2. Diodes Inc's "Green" policy can be found on our website at http://www.diodes.com/products/lead_free/index.php.
 3. Part mounted on FR-4 board with recommended pad layout, which can be found on our website at <http://www.diodes.com/datasheets/ap02001.pdf>.



Electrical Characteristics, NPN Transistor @ $T_A = 25^\circ\text{C}$ unless otherwise specified

Characteristic	Symbol	Min	Max	Unit	Test Condition
OFF CHARACTERISTICS (Note 4)					
Collector-Base Breakdown Voltage	$V_{(BR)CBO}$	45	—	V	$I_C = 100\mu\text{A}, I_E = 0$
Collector-Emitter Breakdown Voltage	$V_{(BR)CEO}$	18	—	V	$I_C = 1\text{mA}, I_B = 0$
Emitter-Base Breakdown Voltage	$V_{(BR)EBO}$	5	—	V	$I_E = 100\mu\text{A}, I_C = 0$
Collector Cutoff Current	I_{CBO}	—	1	μA	$V_{CB} = 40\text{V}, I_E = 0$
Emitter Cutoff Current	I_{EBO}	—	1	μA	$V_{EB} = 4\text{V}, I_C = 0$
ON CHARACTERISTICS (Note 4)					
DC Current Gain	h_{FE}	150	800	—	$I_C = 100\text{mA}, V_{CE} = 1\text{V}$
Collector-Emitter Saturation Voltage	$V_{CE(SAT)}$	—	0.5	V	$I_C = 300\text{mA}, I_B = 30\text{mA}$
SMALL SIGNAL CHARACTERISTICS					
Output Capacitance	C_{obo}	—	8	pF	$V_{CB} = 10\text{V}, f = 1.0\text{MHz}, I_E = 0$
Current Gain-Bandwidth Product	f_T	100	—	MHz	$V_{CB} = 10\text{V}, I_E = 50\text{mA}, f = 100\text{MHz}$

Electrical Characteristics, Zener Element @ $T_A = 25^\circ\text{C}$ unless otherwise specified

Type Number	Zener Voltage Range (Note 5)				Maximum Reverse Leakage Current	
	$V_Z @ I_{ZT}$			I_{ZT}	$I_R @ V_R$	
	Nom (V)	Min (V)	Max (V)	mA	μA	V
DVR1V8W	3.3	3.1	3.5	5	5	1
DVR2V5W	3.9	3.7	4.1	5	3	1
DVR3V3W	4.7	4.4	5.0	5	3	2
DVR5V0W	5.1	4.85	5.36	0.05	5	3

- Note: 4. Short duration test pulse used to minimize self-heating effect.
 5. Nominal Zener voltage is measured with the device junction in thermal equilibrium at $T_J = 30^\circ\text{C} \pm 1^\circ\text{C}$.

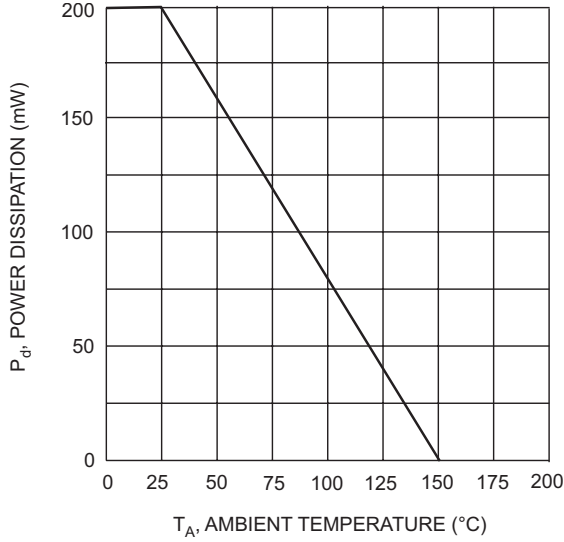

T_A , AMBIENT TEMPERATURE (°C)
Fig. 1, Max Power Dissipation vs Ambient Temperature (Total Device)

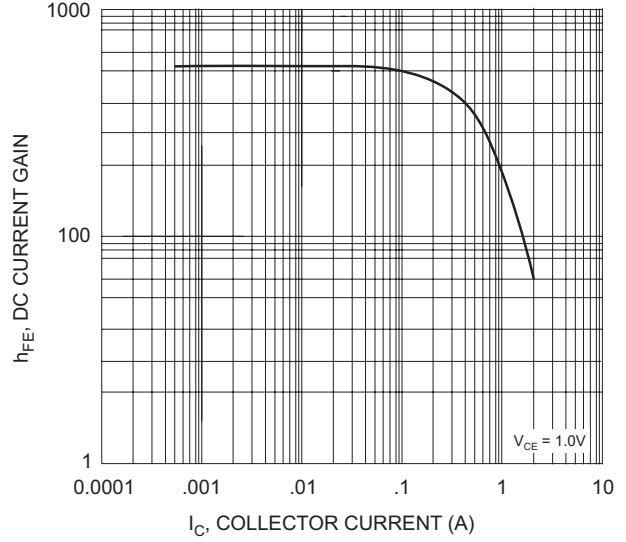

I_C , COLLECTOR CURRENT (A)
Fig. 2, Typical DC Current Gain vs Collector Current (NPN Transistor)

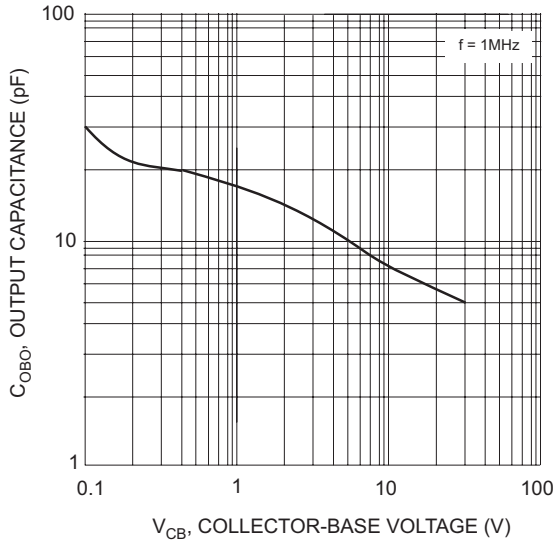

V_{CB} , COLLECTOR-BASE VOLTAGE (V)
Fig. 3, Output Capacitance vs. Collector-Base Voltage (NPN Transistor)

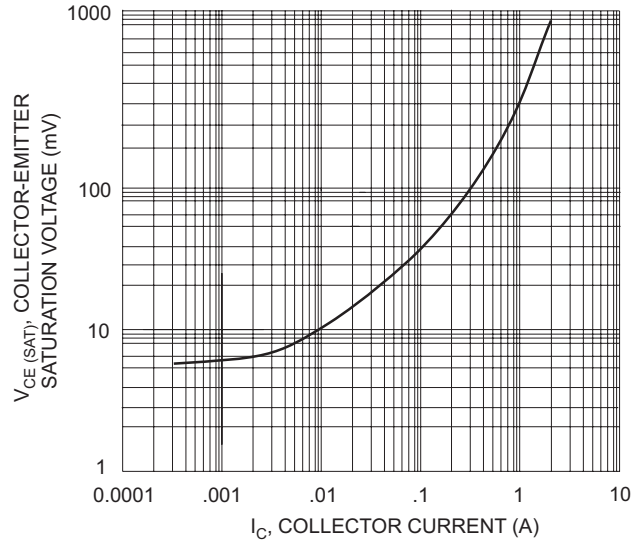

I_C , COLLECTOR CURRENT (A)
Fig. 4, Collector Saturation Voltage vs Collector Current (NPN Transistor)

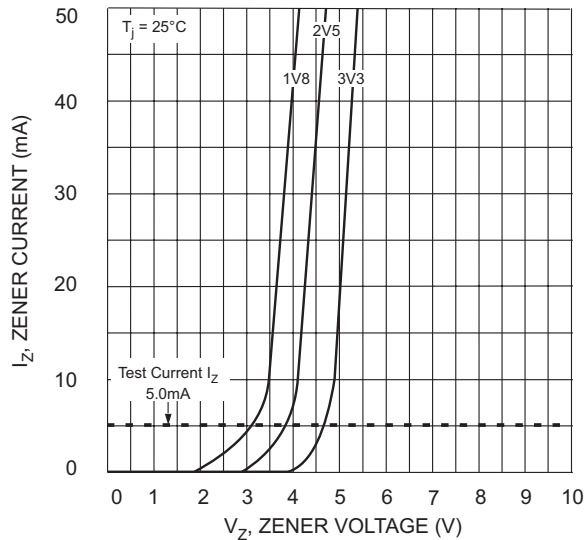

Fig. 5 Zener Breakdown Characteristics (DVR1V8W - DVR3V3W)

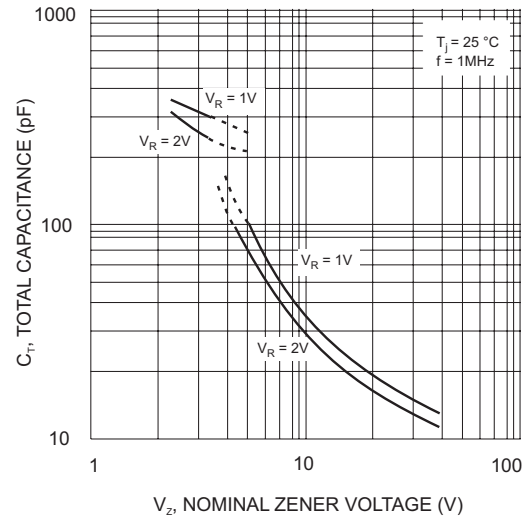

Fig. 6 Total Capacitance vs Nominal Zener Voltage (DVR1V8W - DVR3V3W)

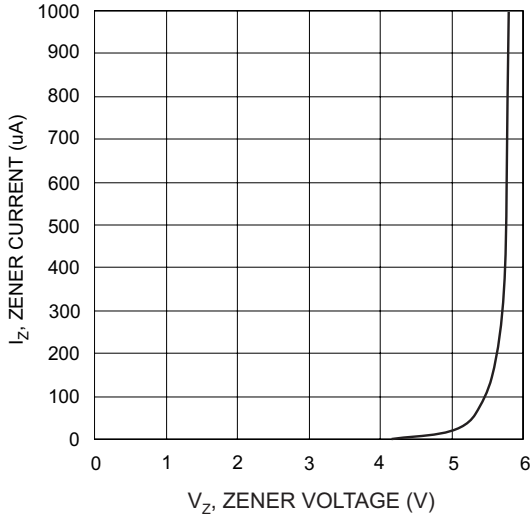

Fig. 7 Zener Breakdown Characteristics (DVR5V0W)

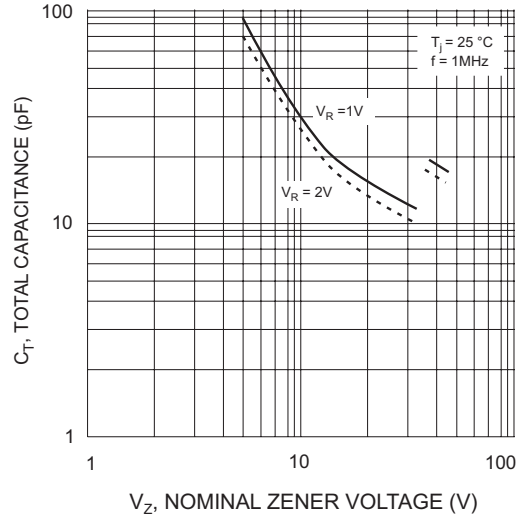

Fig. 8 Total Capacitance vs Nominal Zener Voltage (DVR5V0W)

Ordering Information (Note 6)

Device	Marking Code	Packaging	Shipping
DVR1V8W-7	VR01	SOT-363	3000/Tape & Reel
DVR2V5W-7	VR02	SOT-363	3000/Tape & Reel
DVR3V3W-7	VR03	SOT-363	3000/Tape & Reel
DVR5V0W-7	VR04	SOT-363	3000/Tape & Reel

Notes: 6. For Packaging Details, go to our website at <http://www.diodes.com/datasheets/ap02007.pdf>.

Marking Information

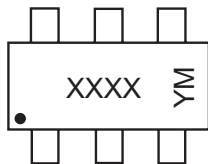

XXXX = Product Type Marking Code,
See Table Above, e.g., VR01 = DVR1V8W
YM = Date Code Marking
Y = Year ex: R = 2004
M = Month ex: 9 = September

Date Code Key

Year	2004	2005	2006	2007	2008	2009
Code	R	S	T	U	V	W

Month	Jan	Feb	March	Apr	May	Jun	Jul	Aug	Sep	Oct	Nov	Dec
Code	1	2	3	4	5	6	7	8	9	O	N	D

Sample Applications

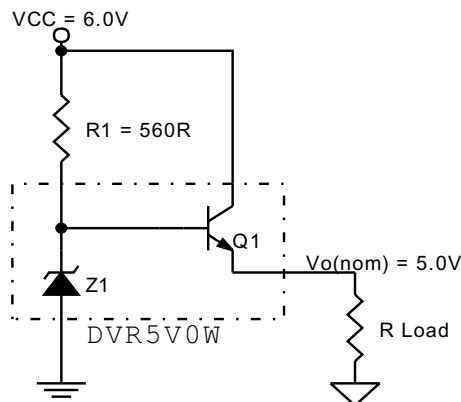

Sample Application for DVR5V0W:
 $V_{CC}^9 = 6.0V$ $R1^7 = 560\Omega$
 $V_{o(nom)} = 5.0V$ $I_o = 100mA$
 $I_q^{(typical)^8} = 0.5mA @ I_o = 0mA$
 Typical⁸ $V_{reg(load)} = 0.2V$ from $I_o = 100mA$ to $0mA$

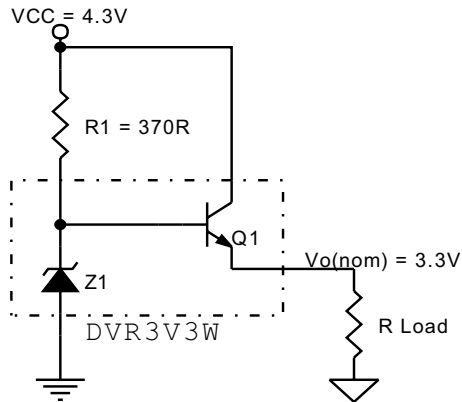

Sample Application for DVR3V3W:
 $V_{CC}^9 = 4.3V$ $R1^7 = 3700\Omega$
 $V_o(nom) = 3.3V$ $I_o = 100mA$
 $I_q(\text{typical}^8) = 0.7mA @ I_o = 0mA$
 $\text{Typical}^8 V_{reg}(\text{load}) = 0.21V \text{ from } I_o = 100mA \text{ to } 0mA$

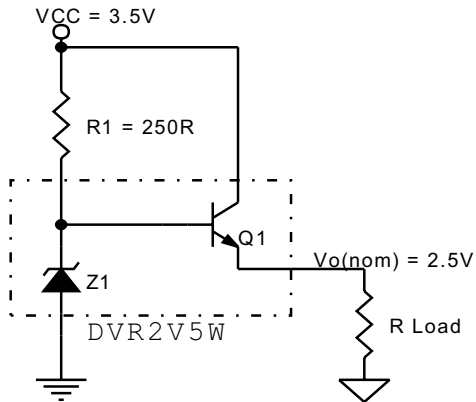

Sample Application for DVR2V5W:
 $V_{CC}^9 = 3.5V$ $R1^7 = 250\Omega$
 $V_o(nom) = 2.5V$ $I_o = 100mA$
 $I_q(\text{typical}^8) = 0.91mA @ I_o = 0mA$
 $\text{Typical}^8 V_{reg}(\text{load}) = 0.13V \text{ from } I_o = 100mA \text{ to } 0mA$

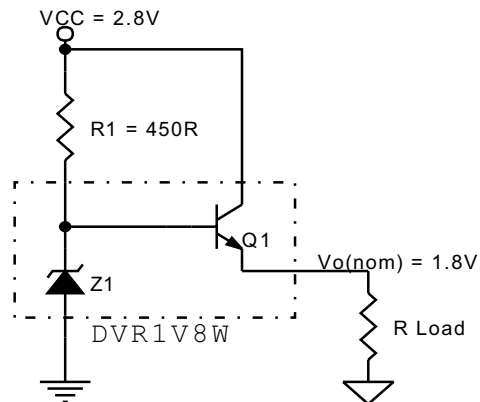

Sample Application for DVR1V8W:
 $V_{CC}^9 = 2.8V$ $R1^7 = 450\Omega$
 $V_o(nom) = 1.8V$ $I_o = 100mA$
 $I_q(\text{typical}^8) = 0.55mA @ I_o = 0mA$
 $\text{Typical}^8 V_{reg}(\text{load}) = 0.25V \text{ from } I_o = 100mA \text{ to } 0mA$

- Notes:
7. Resistor R1 not included.
 8. Typical performance shown is under setup and operating conditions specified in the sample applications.
 9. Recommended $V_{CC}(\text{min}) \approx V_o(\text{nom}) + 1V$.